Bridge manual SP/M/022

Third edition



Superseded

Bridge manual

manual number: SP/M/022

© NZ Transport Agency

www.nzta.govt.nz

Third edition, Amendment 3

Effective from October 2018

ISBN 978-0-478-37162-8 (print)

ISBN 978-0-478-37161-1 (online)

Copyright information

This publication is copyright © NZ Transport Agency. Material in it may be reproduced for personal or in-house use without formal permission or charge, provided suitable acknowledgement is made to this publication and the NZ Transport Agency as the source. Requests and enquiries about the reproduction of material in this publication for any other purpose should be made to:

NZ Transport Agency
Private Bag 6995
Wellington 6141

The permission to reproduce material in this publication does not extend to any material for which the copyright is identified as being held by a third party. Authorisation to reproduce material belonging to a third party must be obtained from the copyright holder(s) concerned.

Disclaimer

The NZ Transport Agency has endeavoured to ensure material in this document is technically accurate and reflects legal requirements. However, the document does not override governing legislation. The NZ Transport Agency and its employees, agents and contractors involved in the preparation and publication of this document do not accept liability for any consequences arising from the use of this document. Users of this document should apply and rely upon their own skill and judgment, and should not rely on the manual's contents in isolation from other sources of advice and information. In applying their own skill and judgment, the standards of safety and serviceability explicitly required or implied by this manual shall not be reduced. If the user is unsure whether the material is correct, they should make direct reference to the relevant legislation or regulations and contact the NZ Transport Agency.

More information

Published 2013
ISBN 978-0-478-37162-8 (print)
ISBN 978-0-478-37161-1 (online)

If you have further queries, call our contact centre on 0800 699 000 or write to us:

NZ Transport Agency
Private Bag 6995
Wellington 6141

This document is available on the NZ Transport Agency's website at www.nzta.govt.nz

Document management plan

1) Purpose

This management plan outlines the updating procedures and contact points for the document.

2) Document information

Document name	<i>Bridge manual</i>
Document number	SP/M/022
Document availability	This document is located in electronic form on the NZ Transport Agency's website at www.nzta.govt.nz .
Document owner	National Structures Manager
Document sponsor	National Manager Professional Services
Prepared by	Opus International Consultants Ltd, Wellington; and Professional Services, NZ Transport Agency

3) Amendments and review strategy

All corrective action/improvement requests (CAIRs) suggesting changes will be acknowledged by the document owner.

	Comments	Frequency
Amendments (minor revisions)	Updates to be notified to users by publication of a technical memorandum placed on the NZ Transport Agency's website.	As required.
Review (major revisions)	Periodic updates will be undertaken where amendments fundamentally changing the content or structure of the manual or new technology resulting from research or ongoing refinement have been identified.	As required.
Notification	All users that have registered their interest by email to bridgemanual@nzta.govt.nz will be advised by email of amendments and updates.	Immediately.

4) Distribution of this management plan

Copies of this manual management plan are to be included in the NZ Transport Agency intranet.

Record of amendments

This document is subject to review and amendment from time to time. Amendments will be recorded in the table below.

Changes since the previous amendment are indicated by a vertical line in the margin. The date of issue or amendment of a page appears in the footer on each page. This page will be updated each time a new amendment is released.

Amendment number	Description of change	Effective date	Updated by
0	The NZTA <i>Bridge manual</i> /3 rd edition published to replace the Transit New Zealand <i>Bridge manual</i> /2 nd edition.	May 2013	Nigel Lloyd
1	Manual disclaimer extended to include contractors. Clauses 2.1.6(c), 3.2.1, 3.4.18(b)(ii), 4.2.1(a), 4.4.2 and 4.7.4(a) amended. Clauses 6.2.1 and 6.2.2 amended for changes in determination of PGAs. Section 7 amended to include 50MAX loading, define loaded lane and loaded length, revise concrete strengths and include alternate statistical analysis for reinforcement strength. Clauses A1.4, A2(c), table A2 and figure A4 notes amended. Appendix F extensively updated and draft status removed.	September 2014	Nigel Lloyd
2	Various amendments made throughout the <i>Bridge manual</i> to clarify requirements for different structure types, in particular bridges, culverts (major and minor), stock underpasses and subways. <i>Highway structures design guide</i> introduced and referenced in clause 1.1. Clauses 2.1.6(c), 2.1.9 and 2.6.3, amended. Clauses 3.2.4, 3.4.12(b) and 3.5(a) amended and clause 3.5(d) added. Collision loading provisions in clause 3.4.18 amended extensively. Grouping of load combinations in tables 3.1, 3.2, D1 and D2 amended. Tsunami loading and load combination 3E added to tables 3.2 and D2. Clauses 4.2.1(j), 4.3.6, 4.7.1(b), 4.7.2(a), 4.7.2(f), 4.10.1, 4.11, 4.12.2 and 4.12.5 amended and clause 4.7.2(g) added. Clauses 5.1.2, 5.2.1, 5.2.3(a) amended and 5.4.10 added. Clause 5.6 <i>Tsunami effects on coastal bridges</i> added. Seismic and non-seismic performance requirements for soil structures collated in clause 6.1.2. Liquefaction assessment, identification and mitigation procedures and design scenarios to consider extensively updated in section 6.3. Clauses 6.6.1 and 6.6.9 amended. Clauses 7.5.1 and 7.5.3(a) amended. Figure A1 amended. Various provisions for pedestrian, cyclist and equestrian barriers moved from section B6 to B2 for consistency. Clauses B2.1, B3.1.4, B3.1.6, B6.3, B6.4 and B6.6, figure B1 and table B2 amended and clause B2.9 added. Clauses D2.2 and D2.5(a) amended and clause D2.6 added. Appendix F amended and moved to <i>Highway structures design guide</i> .	May 2016	Nigel Lloyd

Amendment number	Description of change	Effective date	Updated by
3	<p>Clauses 2.1.1, 2.1.2, 2.1.3, 2.1.5, 2.1.7, 2.1.9 and 2.2, tables 2.1, 2.2, 2.3 and 2.4 and figures 2.1(a), (b) and (c) amended.</p> <p>Clauses 3.2.6, 3.4.6(b), 3.4.8, 3.4.15, 3.4.18(a), 3.4.18(b)(ii) and 3.5(d), figure 3.3 and tables 3.1 and 3.2 amended. Clauses 3.2.7 and 3.4.14(f) added.</p> <p>Clauses 4.2.1(e), 4.2.1(f), 4.3.1, 4.3.3(l), 4.3.6, 4.3.7, 4.4.1, 4.4.2, 4.4.4, 4.7.1(b), 4.7.1(d), 4.7.2, 4.7.3, 4.7.4(a), 4.8.2, 4.8.3, 4.10.1 to 4.10.4, 4.12.2, 4.12.3, 4.12.5 and 4.12.7(b), and tables 4.3 and 4.4 amended. Clauses 4.2.1(b)(viii), 4.3.3(a), (c), (e) to (k), (m) and (n), 4.7.2(h), 4.7.2(i), 4.7.3(g), 4.12.10 and 4.12.11 added.</p> <p>Section 5 amended extensively. New limit states introduced; S_p factor removed; requirements for robustness, $P-\Delta$ effects, force based design, structural forms and relative movement modified; displacement based design introduced as an alternative design method.</p> <p>Section 6 updated to be consistent with section 5, including limit state terminology. Clauses 6.1.2(b)(iii), 6.2.2, 6.3.6, 6.5.4 and 6.6.9 amended. Figure 6.2(b) reinstated.</p> <p>Clauses 7.1.1(b), 7.1.2, 7.1.4, 7.3.2(c), 7.3.3, 7.3.5, 7.3.6(b), 7.4.2, 7.4.3, 7.4.5(d), 7.4.6, 7.5.3(d), 7.5.4 and 7.5.5(d), and table 7.8 amended. Clauses 7.6.5(c) and (d) merged. Clause 7.4.5(i) added.</p> <p>Clauses 8.1, 8.3.2, 8.5.5(c) and 8.5.5(f) amended.</p> <p>Clauses C1.1, C1.2.1, C1.6 and C1.7.1 amended. Clauses C1.7.5 and C1.7.6 added.</p> <p>Clause D2.1 taken out of use.</p> <p><i>Bridge manual commentary</i> introduced (separate document). Addendums 4A, 6A (amended) and 7A moved from <i>Bridge manual</i> to <i>Bridge manual commentary</i>.</p>	October 2018	Nigel Lloyd

(This page is intentionally blank)

Superseded

Foreword

The NZ Transport Agency creates transport solutions for a thriving New Zealand.

We achieve this through our four core business functions:

- planning the land transport networks
- investing in land transport
- managing the state highway network, and
- providing access to and use of the land transport system.

Our structures are an important component of the land transport system. It is through good structures design that the NZ Transport Agency can achieve safety and the economic use of resources. This manual gives guidelines to meet that objective, for the design and evaluation of bridges carrying road and/or pedestrian traffic; for the design of other highway structures such as retaining walls and culverts; and for the design of earthworks such as slopes, embankments and cuttings.

This manual has been produced for the NZ Transport Agency by Opus International Consultants Limited, Wellington, New Zealand. It incorporates the Transit New Zealand Bridge Manual second edition published in 2003 with amendments dated June 2004, September 2004 and July 2005.

This third edition introduces amendments to all sections of the manual incorporating recent advances in structures technology and construction practice. The manual also recognises the introduction of high productivity motor vehicles (HPMVs) through updated evaluation procedures for existing bridges.

Structures technology remains an area of ongoing research and refinement. It is expected that this manual will be reviewed and amended in whole or in part from time to time. Comments from practitioners will therefore be welcomed.

Indeed, amendments to the seismic design elements of the manual are continuing as the construction industry and New Zealand as a whole come to terms with the consequences of the Canterbury earthquakes; and amendments to vehicle load models are under development to anticipate to the future freight task for the country.

Kevin Reid

National Manager Professional Services - Highways and Network Operations
The NZ Transport Agency

Contents

1.0	Introduction	1-1
1.1	Introduction	1-2
1.2	Definitions	1-3
1.3	Acknowledgements	1-4
1.4	Technical approval and certification procedures	1-4
1.5	References	1-4
2.0	Design - General requirements	2-1
2.1	Design philosophy	2-2
2.2	Geometric and side protection requirements	2-13
2.3	Waterway design	2-13
2.4	Site investigations	2-18
2.5	Influence of approaches	2-18
2.6	Urban design	2-19
2.7	Special studies	2-22
2.8	References	2-23
3.0	Design loading	3-1
3.1	Introduction	3-2
3.2	Traffic loads - gravity effects	3-2
3.3	Traffic loads - horizontal effects	3-6
3.4	Loads other than traffic	3-7
3.5	Combination of load effects	3-20
3.6	References	3-23
4.0	Analysis and design criteria	4-1
4.1	Analysis	4-2
4.2	Reinforced concrete and prestressed concrete	4-2
4.3	Structural steel and composite construction	4-12
4.4	Timber	4-20
4.5	Aluminium	4-21
4.6	Other materials	4-21
4.7	Bearings and deck joints	4-21
4.8	Integral and semi-integral abutments	4-29
4.9	Network and tied arch bridges - hanger supports	4-33
4.10	Buried structures	4-35
4.11	Bridges subject to inundation by flooding	4-40
4.12	Miscellaneous design requirements	4-41
4.13	References	4-47

5.0	Earthquake resistant design of structures	5-1
5.1	Scope and design philosophy	5-2
5.2	Design earthquake loading and ductility demand	5-7
5.3	Analysis methods – general	5-15
5.4	Displacement-based analysis methods	5-25
5.5	Force based analysis methods	5-31
5.6	Member design criteria and foundation design	5-36
5.7	Provision for relative displacements	5-53
5.8	Tsunami effects on coastal bridges	5-57
5.9	References	5-63
6.0	Site stability, foundations, earthworks and retaining walls	6-1
6.1	Scope and performance requirements	6-2
6.2	Design loadings and analysis	6-6
6.3	Earthquake induced liquefaction, slope instability and ground deformation	6-19
6.4	Design of earthworks	6-29
6.5	Foundations	6-32
6.6	Earth retaining systems	6-34
6.7	Geofoam road embankments	6-45
6.8	Geosynthetic soil reinforcement	6-45
6.9	References	6-48
7.0	Evaluation of bridges and culverts	7-1
7.1	Introduction	7-2
7.2	Inspection and dynamic load factors	7-5
7.3	Material strengths	7-6
7.4	Main member capacity and evaluation	7-11
7.5	Deck capacity and evaluation	7-18
7.6	Proof loading	7-24
7.7	References	7-28
8.0	Structural strengthening	8-1
8.1	Introduction	8-2
8.2	Approvals	8-2
8.3	Durability	8-3
8.4	Existing structure material strengths	8-3
8.5	Strengthening of flexural members	8-4
8.6	Shear strengthening and ductility enhancement of reinforced concrete columns	8-14
8.7	References	8-15

Appendix A	Bridge widths and clearances	A-1
A1	General	A-2
A2	Bridge deck widths	A-6
A3	Vertical and horizontal clearances	A-11
A4	References	A-13
Appendix B	Barrier systems on structures	B-1
B1	General	B-2
B2	Types of barrier system and their applications	B-2
B3	Barrier performance selection method	B-5
B4	Barrier acceptance criteria	B-10
B5	Standard solutions	B-11
B6	Side protection design criteria	B-11
B7	Geometric layout, end treatment and transitions - the NZTA's requirements	B-16
B8	Non-proprietary bridge barrier system	B-18
B9	References	B-22
Appendix C	Seismic hardware	C-1
C1	Linkage bars	C-2
C2	Toroidal rubber buffers	C-6
C3	References	C-7
Appendix D	Lightly trafficked rural bridges and other structures	D-1
D1	General	D-2
D2	Specific requirements	D-2
D3	References	D-6
Appendix E	Structure site information summary	E-1
Appendix F	Technical approval, review and certification procedures	F-1
F1	References	F-2

1.0 Introduction

In this section	Section	Page
	1.1 Introduction	1-2
	1.2 Definitions	1-3
	1.3 Acknowledgements	1-4
	1.4 Technical approval and certification procedures	1-4
	1.5 References	1-4

1.1 Introduction

This *Bridge manual* sets out the criteria for the design and evaluation of bridges, culverts, stock underpasses and subways and the design of earthworks and retaining structures. The manual is a companion document to the overarching *Highway structures design guide*⁽¹⁾, which provides general and specific design criteria for all highway structures.

The manual has been developed by the NZ Transport Agency (NZTA) for use on state highways or for the design of other new or replacement bridges proposed for funding from the National Land Transport Fund (NLTF). Use of the manual on other highways, including private highways, may be considered appropriate with the agreement of the relevant road controlling authority, client or landowner.

Specifically the *Bridge manual* covers:

- bridges carrying road and/or pedestrian traffic, in which the main supporting members are of reinforced or prestressed concrete, structural steel, timber or aluminium, utilising beam or arch action, and spanning up to 100 metres
- stock underpasses and pedestrian subways
- all culverts or multiple culverts with a total waterway area greater than 3.4m², referred to herein as 'major culverts'
- slopes, embankments and cuttings
- retaining wall systems such as gravity walls, cantilever walls, mechanically stabilised earth walls and anchored walls.

The manual does not include suspension or cable-stayed bridge structures, nor structures subject to railway loadings.

The manual also does not specifically cover all forms of "other highway structures", such as sign gantries, sign supports, lighting supports, noise walls and fences. Details for these structures can be found in the *Highway structures design guide*⁽¹⁾.

The *Bridge manual* has been written as a performance specification, and methods have only been specified where they are considered essential to achieving a satisfactory design.

1.1 continued

This edition of the *Bridge manual* supersedes the following previously published documents:

1933	<i>Road bridges: Loads and allowable stresses</i> , Public Works Department.
1943	<i>Highway bridge design loadings and tentative preliminary code</i> , Technical Memorandum No. 8, Public Works Department.
1956	<i>Bridge manual</i> , Ministry of Works.
1971, 1972, 1973, 1978	<i>Highway bridge design brief</i> , CDP 701, Ministry of Works and Development.
1973	<i>Bridge classification and deck grading for overweight permits</i> , CDP 703, Ministry of Works and Development.
1974	<i>Posting weight limits for highway bridges</i> , CDP 704, Ministry of Works and Development.
1984	<i>Bridge deck widths and side protection</i> , CDP 710, Ministry of Works and Development.
1989	<i>Bridge manual</i> , National Roads Board.
1991	<i>Bridge manual: Design and evaluation</i> , (draft for comment), Transit New Zealand.
1994, 2000	<i>Bridge manual</i> , 1 st edition, Transit New Zealand.
2003	<i>Bridge manual</i> , 2 nd edition, Transit New Zealand.

1.2 Definitions

The following definitions shall be used preferentially in the naming of and reference to bridges and other highway structures on the state highway network:

Term	Definition
Bridge	A structure designed to carry a road or path over an obstacle by spanning it.
Culvert	One or more adjacent pipes or enclosed channels for conveying surface water or a stream below formation level. (Note that a culvert or multiple culverts with a total waterway area greater than 3.4m ² is referred to herein as a major culvert, where any distinction is required. This distinction is not required for naming purposes.)
Overpass	A grade separation where the subject carriageway passes over an intersecting carriageway or railway.
Stock underpass	A structure constructed to permit the passage of stock beneath a road.
Subway	A structure constructed to permit the passage of pedestrians, cyclists or equestrians beneath the road.
Underpass	A grade separation where the subject carriageway passes under an intersecting carriageway or railway.

1.3 Acknowledgements

The assistance provided by D Kirkcaldie Consulting Limited, Opus International Consultants Limited and John Wood Consulting in the preparation of this manual is acknowledged. The contributions made by the late Professor Nigel Priestley, Professor Misko Cubrinovski and the University of Auckland under Professor Bruce Melville in the development of aspects of sections 5 and 6 are also acknowledged.

The assistance provided by Beca Infrastructure Limited, Bloxam Burnett & Olliver Limited and RoadLab Limited in the review of this manual is acknowledged.

Section B3.2 contains text taken from AS 5100.1-2004 *Bridge design* part 1 Scope and general principles⁽²⁾. Reprinted with the permission of Standards Australia Limited.

1.4 Technical approval and certification procedures

Details of the technical approval and certification procedures required by the NZTA for highway structures on state highways are contained within appendix A of the *Highway structures design guide*⁽¹⁾. Details of the requirements for structure options reports, structure design statements, design certification, design review certification, construction certification and construction review certification are contained therein.

1.5 References

-
- (1) NZ Transport Agency (2016) *Highway structures design guide*. Wellington.
 - (2) Standards Australia AS 5100.6-2004 *Bridge design*. Part 1 Scope and general principles. Superseded.
-

2.0 Design - General requirements

In this section

	Section	Page
2.1	Design philosophy	2-2
2.2	Geometric and side protection requirements	2-13
2.3	Waterway design	2-13
2.4	Site investigations	2-18
2.5	Influence of approaches	2-18
2.6	Urban design	2-19
2.7	Special studies	2-22
2.8	References	2-23

2.1 Design philosophy

2.1.1 General

Highway structures shall be designed to satisfy the requirements of both the ultimate and the serviceability limit states when acted on by any of the combinations of loading defined in this document.

During the design process all relevant factors affecting the design, such as those listed in broad terms in section 2 of a structure options report, shall be taken into account to ensure compliance with all relevant legislation and regulations. Detailing shall be such that it promotes ease of construction and ease of maintenance. Specifically, the Transport Agency's ZH/MS/01 *Safety in design minimum standard for road projects*⁽¹⁾ shall be adopted for safety in design processes to be utilised on state highway projects. The processes may result in additional or modified design requirements for highway structures.

Construction methods shall be considered, in order to avoid undue expense due to unnecessarily complicated procedures. However, methods shall not be specified unless they contain features essential to the design assumptions.

2.1.2 Definition of terms

Serviceability limit state (SLS): The state beyond which a structure becomes unfit for its intended use through deformation, vibratory response, degradation or other operational inadequacy.

Ultimate limit state (ULS): The state beyond which the strength or ductility capacity of the structure is exceeded, or when it cannot maintain equilibrium and becomes unstable.

Design working life: The design working life of a structure is that life beyond which the structure will be expected to have become functionally obsolete or to have become uneconomic to maintain in a condition adequate for it to perform its functional requirements.

Major renovation: Maintenance work costing more than 20% of the replacement value of the structure, necessary to maintain the strength, ductility capacity, or serviceability of a structure to enable it to fulfil its functional requirements.

Note also the definitions of **damage control limit state (DCLS)** and **collapse avoidance limit state (CALC)** in 5.1.2 for the design of structures for earthquake resistance.

2.1.3 Basis of design

Design to this document is based on limit state principles adopting where possible a statistical approach to the derivation of design loads and material strengths.

Design actions other than earthquake, wind, snow and floodwater are based on a statistical distribution appropriate to a 100-year design working life. Where statistical distributions are not available, design actions are based on judgment and experience. For dead and live load, the target probability of exceedance within 100 years that has been adopted is 5%.

For wind, snow, floodwater and earthquake actions, bridges, earth retaining structures and earth slopes shall be categorised into an importance level for which the assigned annual probabilities of exceedance for these actions shall be as given in tables 2.1, 2.2 and 2.3 respectively. For the categorisation into importance level and assignment of annual probabilities of exceedance, major culverts, stock underpasses and pedestrian or cycle subway shall be treated as bridges.

2.1.3 continued

Both the structure and non-structural elements shall remain undamaged following wind, snow and flood events up to an SLS 1 event, and the bridge, major culvert, stock underpass, pedestrian or cycle subway, or earth retaining structure shall remain operationally functional for all highway traffic during and following flood events up to an SLS 2 event. SLS 1 and SLS 2 events are serviceability limit state events defined by the annual probabilities of exceedance given in tables 2.1 and 2.2. Performance requirements during and following an earthquake are presented in section 5.

All bridges, other than footbridges, that span other roads or railways shall be designed for an importance level being the greater of their own importance level and that of the road or railway crossed.

Footbridges shall be designed for the greater of their own importance level and an importance level one category less than the importance of the road or railway crossed. For the requirements of this clause the importance level of a railway shall be taken as importance level 3.

Non-integral bridge abutment walls and independent walls associated with bridges (as defined in 6.6.1(a)(i)) shall be designed for the same annual probability of exceedance events as adopted for the bridge and earth slopes on which a bridge depends for its support and stability. This requirement applies similarly to other forms of structure such as major culverts, stock underpasses and pedestrian/cycle subways.

Where a slope failure may impact on property of significant value or importance the slope shall be assigned an annual probability of exceedance for the ultimate limit state event corresponding to that for retaining walls protecting property of similar value.

2.1.4 Design standards

This document defines design loadings, load combinations and load factors, together with criteria for earthquake resistant design, and other miscellaneous items. It does not define detailed design criteria for the various materials, but refers to standards such as those produced by Standards New Zealand, Standards Australia and the British Standards Institution. The standards referred to shall be the editions referenced, including all current amendments. The specified portions of these standards are to be read as part of this document but any references in such standards to specific loads or load combinations shall be disregarded.

2.1.5 Design working life requirements

For the purpose of assessing probabilistic effects of live load fatigue, and for consideration of long-term effects such as corrosion, creep and shrinkage, the design working life of a bridge or an earth retaining structure is assumed to be 100 years in normal circumstances.

This may be varied by the controlling authority if circumstances require it, for example for temporary structures, for strengthening of existing structures or for increasing the design life of landmark or high value structures. It should be noted that the 100-year design working life exceeds the minimum requirement of the *Building code*⁽²⁾.

The design working life of a major culvert shall be assumed to be as above for a bridge except when designed on the basis of specific provision for future rehabilitation, as set out in 4.10.1. The reduced design working life of the initial construction may be adopted as the basis for assessing the probabilistic effects of live load fatigue, and for consideration of long-term effects such as corrosion, creep and shrinkage.

Guidance for determining the design working life of other highway structures is given in the *Highway structures design guide*⁽³⁾.

Table 2.1: Importance level and annual probabilities of exceedance for wind, snow, floodwater and earthquake actions for bridges

Bridge categorisation	Importance level (as per AS/NZS 1170.0 ⁽⁴⁾)	Bridge permanence [*]	Annual probability of exceedance for the ultimate limit state		Annual probability of exceedance for the serviceability limit state	
			ULS for wind, snow and floodwater actions	DCLS [†] for earthquake actions	SLS 1 for wind, snow and floodwater actions	SLS 2 for floodwater actions
Bridges of high importance to post-disaster recovery (eg bridges in major urban areas providing direct access to hospitals and emergency services or to a major port or airport from within a 10km radius). Bridges with a construction cost (including associated ground improvements) exceeding \$16 million (as at June 2018) [‡] .	4	Permanent	1/2500	1/2500	1/25	1/100
		Temporary	1/1000	1/1000	1/25	1/100
Bridges on highways classified as National (High Volume) in the One Network Road Classification [§] (ONRC).	3+	Permanent	1/1500	1/1500	1/25	1/100
		Temporary	1/700	1/700	1/25	-
Bridges on highways classified as National, Regional, Arterial, Primary Collector or Secondary Collector in the ONRC.	3	Permanent	1/1000	1/1000	1/25	1/100
		Temporary	1/500	1/500	1/25	-
Bridges on highways classified as Access or Access (Low Volume) in the ONRC. Bridges, not falling into other levels. Footbridges.	2	Permanent	1/500	1/500	1/25	1/50
		Temporary	1/250	1/250	1/25	-
Bridges where failure would not be likely to endanger human life and the loss of which would not be detrimental to post-disaster recovery activities for an extended period.	1	Permanent	1/250	1/250	1/25	1/25
		Temporary	1/50	1/50	-	-

Notes:

- * Permanent bridge: design working life = 100 years assumed (see 2.1.3, 2.1.5). Temporary bridge: design working life ≤ 5 years.
- † DCLS – damage control limit state. See 5.1.2 (a) for definition.
- ‡ Values shall be adjusted to current value. For the relevant cost adjustment factor refer to the NZ Transport Agency's (NZTA) *Procurement manual*, Procurement manual tools, Latest values for 1991 infrastructure cost indexes, NZ Transport Agency Bridge index⁽⁵⁾.
- § The One Network Road Classification (ONRC) is a classification system, which divides New Zealand's roads into six categories based on how busy they are, whether they connect to important destinations, or are the only route available (see *One network road classification*⁽⁶⁾). See figures figure 2.1(a), 2.1(b) and 2.1(c) herein for the classification of state highways or *Tables of state highways in each ONRC classification category*⁽⁷⁾.

Table 2.2: Importance level and annual probabilities of exceedance for storm*, floodwater and earthquake actions for earth retaining structures

Retaining structure categorisation	Importance level (as per AS/NZS 1170.0 ⁽⁴⁾)	Height H [†] (m)	Area A [†] (m ²)	Annual probability of exceedance for the ultimate limit state		Annual probability of exceedance for the serviceability limit state	
				ULS for storm and floodwater actions	DCLS for earthquake actions	SLS 1 for storm and floodwater actions	SLS 2 for storm and floodwater actions
Retaining structures associated with bridges	As for the associated bridge						
Retaining structures providing route security							
Retaining structures critical to post-disaster recovery (eg retaining walls, the failure of which could completely close important roads in major urban areas providing direct access to hospitals and/or emergency services, or to a major port or airport from within a 10km radius).	4			1/2500	1/2500	1/25	1/100
Retaining structures on highways classified as National (High Volume) in the One Network Road Classification (ONRC).	3+	≥ 5 and	≥ 100	1/1500	1/1500	1/25	1/100
	3	< 5 or	< 100	1/1000	1/1000	1/25	1/100
Retaining structures on highways classified as National, Regional, Arterial, Primary Collector or Secondary Collector in the ONRC.	3	≥ 5 and	≥ 100	1/1000	1/1000	1/25	1/100
	2	< 5 or	< 100	1/500	1/500	1/25	1/50
Retaining structures on highways classified as Access or Access (Low Volume) in the ONRC.	2	≥ 5 and	≥ 50	1/500	1/500	1/25	1/50
	1	< 5 or	< 50	1/250	1/250	1/25	1/25
Retaining structures the failure of which would not be likely to endanger human life or would not affect the use of the road; or the loss of which would not be detrimental to post-disaster recovery activities for an extended period.	1			1/250	1/250	1/25	1/25
Retaining structures providing protection to adjacent property							
Retaining structures protecting against loss or significant loss of functionality to adjacent property categorised as:							
having special post disaster functions (ie importance level 4 or above as listed in AS/NZS 1170.0 ⁽⁴⁾ table 3.2).	4			1/2500	1/2500	1/25	1/100
importance level 3 by AS/NZS 1170.0 ⁽⁴⁾ table 3.2.	3			1/1000	1/1000	1/25	1/100
importance level 2 by AS/NZS 1170.0 ⁽⁴⁾ table 3.2.	2			1/500	1/500	1/25	1/50
Retaining structures protecting adjacent property, the consequential reinstatement cost of which would exceed \$1.4 million (as at June 2018) [‡] , not otherwise an importance level 3 or 4 structure.	2			1/500	1/500	1/25	1/50
Retaining structures the failure of which would not significantly endanger adjacent property.	1			1/250	1/250	1/25	1/25
Retaining structures not falling into other levels	2			1/500	1/500	1/25	1/50

Notes:

* Storm includes the effects of rainwater (ie ponding and groundwater pressure).

† The maximum height H shall be measured to where a line from the ground level at the front of the wall, inclined at 45°, intersects the ground surface behind the wall. The face area A shall be calculated using the height H defined thus.

‡ Values shall be adjusted to current value. For the relevant cost adjustment factor refer to the NZTA's *Procurement manual*, Procurement manual tools, Latest values for 1991 infrastructure cost indexes, NZ Transport Agency Construction index⁽⁵⁾.

Table 2.3: Importance level and annual probabilities of exceedance for storm*, floodwater and earthquake actions for earth slopes

Earth slope categorisation	Importance level (as per AS/NZS 1170.0 ⁽⁴⁾)	Slope type	Annual probability of exceedance for the ultimate limit state	
			ULS for storm and floodwater actions	DCLS for earthquake actions
Earth slopes affecting bridges[†]	As for the bridge affected			
Earth slopes providing route security				
Earth slopes on routes critical to post-disaster recovery (eg routes in major urban areas providing direct access to hospitals and/or emergency services, or to a major port or airport from within a 10km radius).	4	Fill > 6m high	1/2500	1/2500
		Fill ≤ 6m high and all cuts	1/1000	1/1000
Earth slopes on highways classified as National (High Volume) in the One Network Road Classification (ONRC).	3+	Fill > 6m high	1/1500	1/1500
		Fill ≤ 6m high and all cuts	1/700	1/700
Earth slopes on highways classified as National, Regional, Arterial, Primary Collector or Secondary Collector in the ONRC.	3	Fill > 6m high	1/1000	1/1000
		Fill ≤ 6m high and all cuts	1/500	1/500
Earth slopes on highways classified as Access or Access (Low Volume) in the ONRC.	2	Fill > 6m high	1/500	1/500
		Fill ≤ 6m high and all cuts	1/100	1/100
Earth slopes the failure of which would not be likely to endanger human life or would not affect the use of the road; or the loss of which would not be detrimental to post-disaster recovery activities for an extended period.	1	Fill > 6m high	1/100	1/100
		Fill ≤ 6m high and all cuts	1/50	1/50
Earth slopes providing protection to adjacent property				
Earth slopes protecting against loss or significant loss of functionality to adjacent property categorised as:				
having special post disaster functions (ie importance level 4 or above as listed in AS/NZS 1170.0 ⁽⁴⁾ table 3.2).	4	All	1/2500	1/2500
importance level 3 by AS/NZS 1170.0 ⁽⁴⁾ table 3.2.	3	All	1/1000	1/1000
importance level 2 by AS/NZS 1170.0 ⁽⁴⁾ table 3.2.	2	All	1/500	1/500
Earth slopes protecting adjacent property, the consequential reinstatement cost of which would exceed \$1.4 million (as at June 2018) [‡] , not otherwise an importance level 3 or 4 slope.	2	All	1/500	1/500
Earth slopes the failure of which would not significantly endanger adjacent property.	1	Fill > 6m high	1/100	1/100
		Fill ≤ 6m high and all cuts	1/50	1/50
Earth slopes not falling into other levels	2	Fill > 6m high	1/500	1/500
		Fill ≤ 6m high and all cuts	1/100	1/100

Notes:

Where achieving the specified level of performance results in excessively high cost, an approach based on an assessment of the risks versus the cost may be promoted to the road controlling authority for their acceptance.

* Storm includes the effects of rainwater (ie ponding and groundwater pressure).

† Slopes affecting bridges are those that have the potential to collapse onto a bridge or to result in loss of support of a bridge if the slope fails.

‡ Values shall be adjusted to current value. For the relevant cost adjustment factor refer to the NZTA's *Procurement manual*, Procurement manual tools, Latest values for 1991 infrastructure cost indexes, NZ Transport Agency Construction index⁽⁵⁾.

Figure 2.1(a): North Island One Network Road Classification for state highways

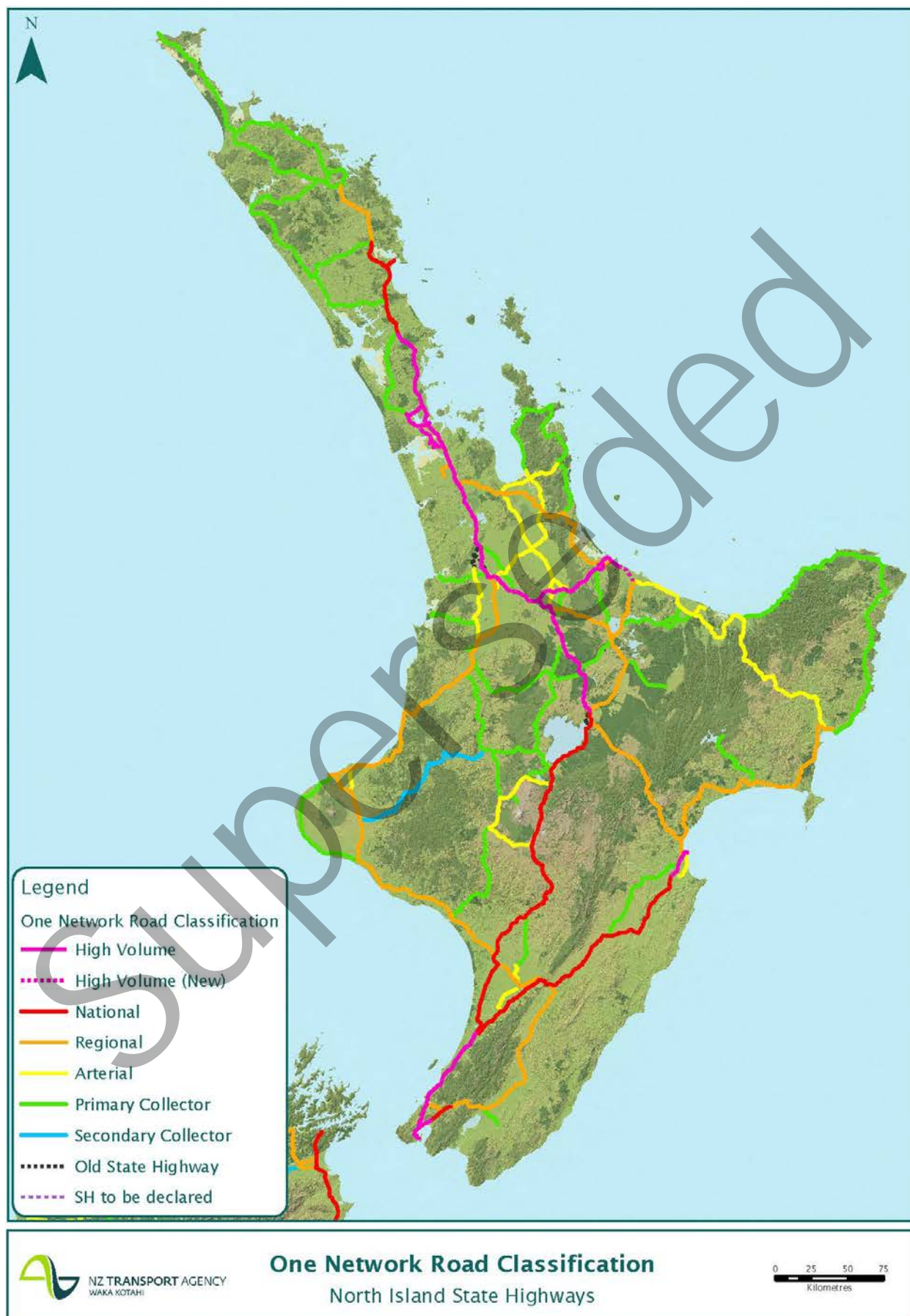

Figure 2.1(b): South Island One Network Road Classification for state highways

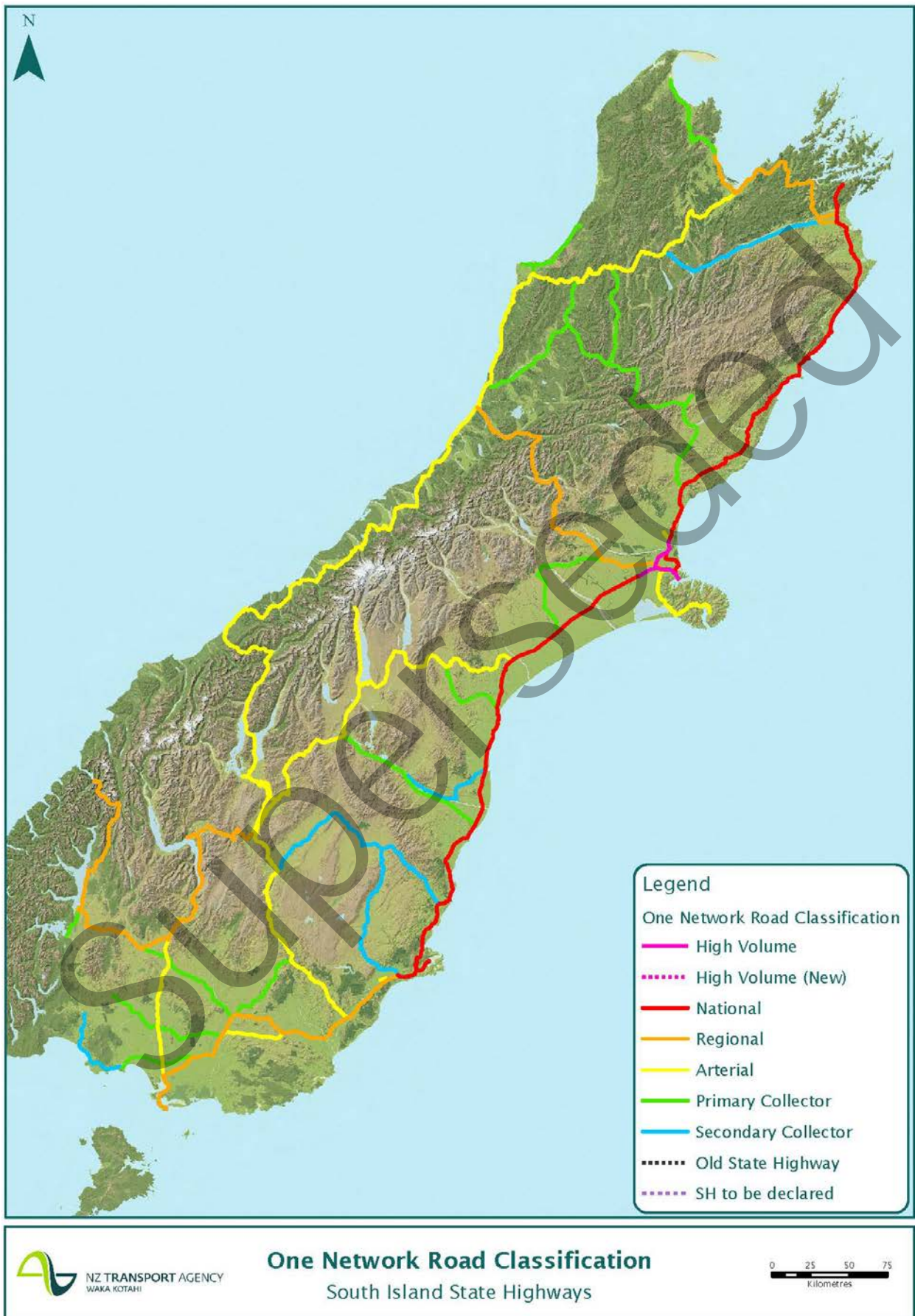
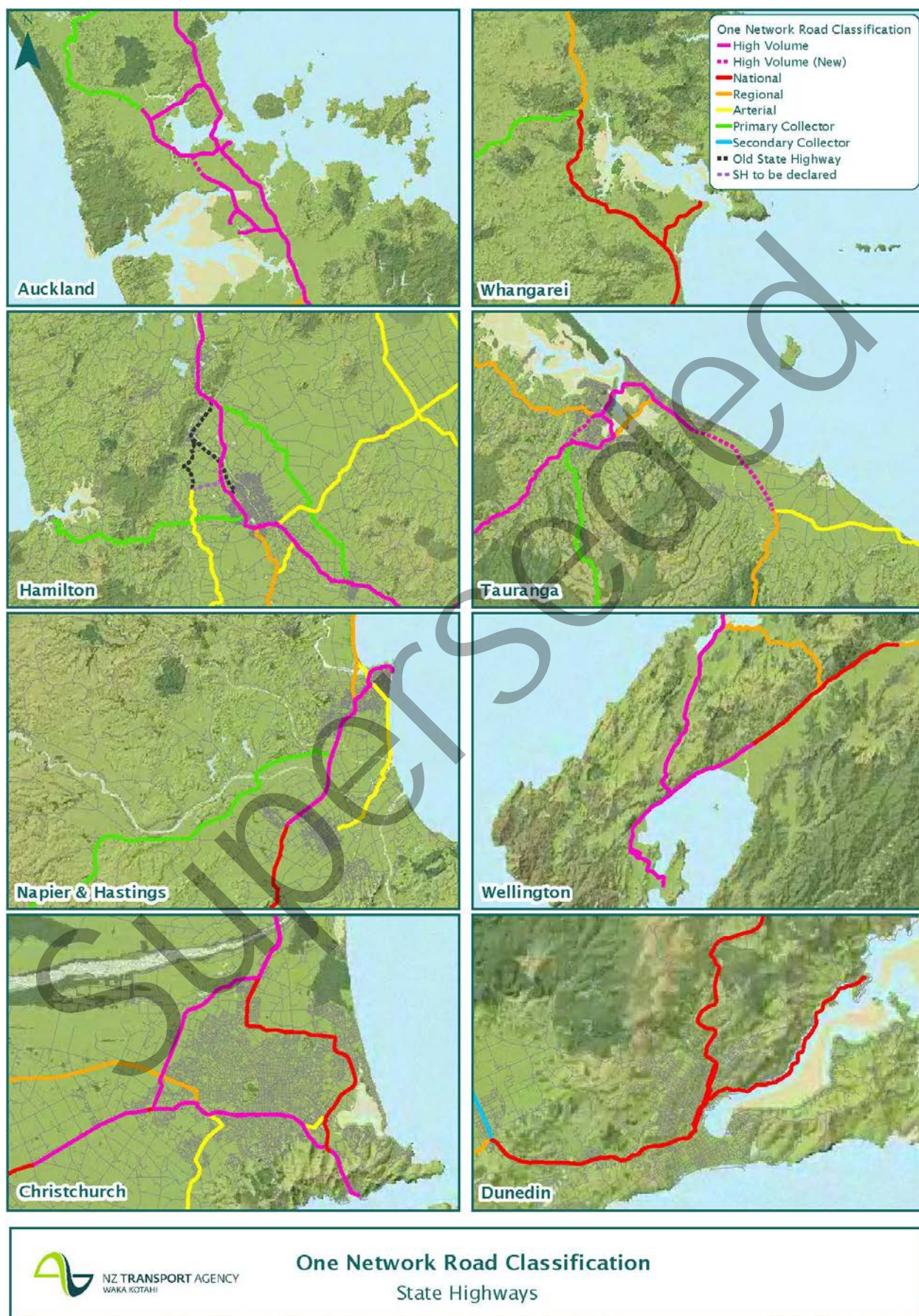

Figure 2.1(c): Selected urban areas One Network Road Classification for state highways



2.1.6 Durability requirements

a. General

The structure and its component members shall be designed to provide adequate durability in accordance with the requirements of the material design standards, except where specific requirements are included in this document, which shall take precedence.

Structures shall be sufficiently durable to ensure that, without reconstruction or major renovation, they continue to fulfil their intended function throughout their design life.

b. Replaceable elements

Replaceable elements of a structure (eg proprietary bridge deck movement joints, bearings, seismic restraints) shall have a minimum life of 40 years to major maintenance or replacement, and shall be replaceable without the need for major modification to adjacent elements. Corrosion protection systems shall satisfy the requirements of 4.3.6.

c. Cast-in items

Cast-in items shall have a design life of 100 years. Unless the cast-in portions are sealed from exposure to the atmosphere by concrete cover complying with NZS 3101.1&2 *Concrete structures standard*⁽⁸⁾ table 3.7 or by the attachment plates of the fixed hardware (with grout or mortar present between attachment plates and concrete), cast-in items and fixings shall be of grade 316 stainless steel or other suitable non-ferrous material that does not introduce bimetallic corrosion unless otherwise explicitly stated in this manual or referenced NZTA specifications.

d. Water staining

Where appropriate, the edges of concrete elements shall include drip details to avoid water staining and to keep the locations of bearings, seismic restraints and post-tensioning hardware dry.

2.1.7 Structural robustness

All parts of the structure shall be interconnected, in both horizontal and vertical planes, to provide the structure with the robustness to adequately withstand unanticipated extreme loading events such as extreme flood, earthquake or vehicle collision.

In detailing the various elements of a structure, the effect of that detailing on the robustness of the structure as a whole to unanticipated extreme loading events shall be considered and robustness of the structure shall be ensured.

Hold-down devices shall be provided at all supports of bridges where the net vertical reaction under damage control limit state conditions for earthquake, or ultimate limit state design conditions for flood, wind or collision by a vehicle, train or ship is less than 50% of the dead load reaction. In the case of propped cantilever spans and in-span structural hinges, hold-down devices shall be provided regardless.

The hold-down device shall have sufficient strength to prevent uplift of the span from its support under the above damage control limit state or ultimate limit state design conditions as appropriate but not less than sufficient strength to resist a force equal to 20% of the dead load reaction. In the case of a cantilever span, free or propped, the minimum design strength of the hold-down device at the end of the cantilever shall be calculated on the basis of 20% of the dead load reaction which would exist if the cantilever span was simply supported. The restraint against lift and buoyancy forces imposed by flood flow shall also be not less than that specified by 3.4.8. An elastomeric bearing shall not form part of a hold-down device.

2.1.7 continued

A positive lateral restraint system shall also be provided between the superstructure and the substructure at piers and abutments, except at abutments that satisfy the overlap requirements of 5.7.2(d). The restraint system for each continuous section of the superstructure shall be capable of resisting an ultimate design horizontal force normal to the bridge centreline of not less than 500kN or 5% of the superstructure load at that support, whichever is greater. The requirements of 5.7.2 shall also be complied with. For continuous superstructures, lateral restraints may be omitted at some supports provided that each continuous section of the superstructure between expansion joints is at least equivalently restrained. Supports providing this lateral restraint shall also be designed to resist this design force.

Restraints shall have sufficient lateral clearance to allow thermal movements unless the structure is specifically designed for the induced forces from thermal expansion and contraction arising from lack of lateral clearance.

2.1.8 Tolerances on bridge alignment, profile and level over the design life

The design and construction of bridges shall be such that any long-term time related changes to the vertical profile of the bridge deck from the specified design levels (eg creep and shrinkage for a concrete structure, settlement of foundations and long term subsidence) are such that they do not exceed the following during the design life of the bridge:

- $\pm 25\text{mm}$ from the specified design levels for the substructure, and
- span/1000 from the specified design vertical alignment for the superstructure.

2.1.9 Access and provisions for inspection and maintenance

All parts of structures except buried surfaces shall be accessible for the purposes of inspection and maintenance. Details of proposed arrangements for inspection and maintenance, including provisions for access shall be given in the structure options report and the structure design statement.

Access shall generally be achievable using readily available proprietary mobile inspection equipment (including elevated work platforms, under bridge inspection units and roped access), with no need for fixed scaffolding.

Where this is not reasonably possible for a bridge (eg where the superstructure extends above deck level on through-truss and arch spans or where the superstructure is greater than 20m wide) a means of providing access to all areas of the superstructure soffit and pier tops shall be installed on the bridge (eg permanent walkways and working platforms), unless agreed otherwise by the road controlling authority.

A means of enabling the construction of a temporary working platform for the maintenance of structures shall be installed on structures where this cannot be readily achieved from the ground or no such permanent provision is present. This may require the provision of permanent fixing points.

Permanent access ladders and fittings shall be limited to locations that are not visible to the public and shall be provided as required to access bearings, expansion joints and other maintainable parts of the structure. In all cases, access provision shall consider any requirements for safety from falling protection as discussed in 6.6.1(c)(ii) for the top of retaining structures within the highway reserve but remote from the road, where there may be the occasional presence of people.

Access points shall only be located in areas where access does not require traffic management of any highway or railway, and particularly they shall not be located directly above any carriageway or railway line.

2.1.9 continued

For abutments the following elements shall be accessible for inspection and reachable for maintenance, generally from in front of the abutment:

- the front face of integral or semi-integral abutments or the front face of superstructure end diaphragms where the abutment is non-integral
- bearings to enable extraction and replacement, and also to position and withdraw jacks
- any drainage channel at the base of the abutment backwall, to enable accumulated debris to be cleared
- linkage bolts, and any rubber buffers installed on them.

At abutments with spill-through slopes or mechanically stabilised earth walls or slopes in front of the abutment sill beam, this may be achieved by providing a level walkway access and working area at least 600mm wide in front of the abutment sill beam over the full length of the abutment. Where the abutment sill is supported on a vertical or near vertical retaining wall or vertical or near vertical mechanically stabilised earth wall and access to the abutment sill area and bearings can readily be gained using proprietary mobile inspection equipment, provision of the 600mm wide working area in front of the sill may be omitted.

Unbonded prestressing tendons or bars shall be accessible for inspection and shall be replaceable without the need for modification to adjacent structural elements.

At all supports where the bridge superstructure is supported on bearings, other than solid or voided deck slab bridges on strip bearings, provision shall be made for the superstructure to be able to be jacked for bearing replacement without the positioning of jacks unduly impeding access to the bearings for their removal and replacement. Bearings shall be replaceable under full HN live load, ie load combination 1A as defined in table 3.2.

Multi-beam bridge superstructures shall be provided with diaphragms or an equivalent permanent structure at the ends of each span designed to facilitate jacking of the bridge superstructure using the minimum number of jacks practicable. (As a guide, for simply supported spans of up to 35m this should be no more than one jack per 3.0m width of bridge deck, per support.) Design for jacking of the bridge shall accommodate continued use of the bridge by traffic while the jacking of spans is undertaken.

Hollow box girders, hollow piers, abutments and similar hollow components shall be accessible on the inside for inspection and maintenance. Suitable access penetrations of minimum aperture specified in section 19 of *AASHTO Guide specification for design and construction of segmental concrete bridges*⁽⁹⁾, shall be provided through diaphragms, slabs or end walls for such cases. Apertures through box girder diaphragms shall be sized, positioned and detailed to allow practical access for personnel and all required maintenance plant and equipment without any need for ladders, lifting equipment, or other assistance.

Access manholes shall not be located in the upper flange of bridge superstructures. All doors and access manholes shall have efficient waterproof seals, be self-closing and have security locks with at least three spare keys per lock, all uniquely identified to the associated lock.

Major culverts located in rivers or streams that transport significant amounts of gravel or debris that is expected to accumulate within the structure on a relatively frequent basis and require clean-out shall be provided with sufficient internal working room to enable access by mechanical plant, subject to road controlling authority approval.

2.2 Geometric and side protection requirements

Carriageway and footpath widths, and horizontal and vertical clearances shall comply with appendix A as a minimum. Clearances over railways shall comply with the requirements of KiwiRail – New Zealand Railways Corporation.

Requirements for pedestrians, cyclists and equestrians shall be agreed with the road controlling authority. Guidance on criteria that may be appropriate may be found in appendix A. As a general principle, the widths of traffic lanes and shoulders, together with any additional facilities for pedestrians and cyclists on bridges or adjacent to retaining structures shall match, wherever practicable, those of the road on the approaches. This also applies where roads cross over culverts, stock underpasses and subways.

Side protection to all new structures, or replacement of side protection on existing structures, shall be provided in accordance with the requirements of AS/NZS 3845 *Road safety barrier systems and devices part 1 Road safety barrier systems*⁽¹⁰⁾ as implemented by the NZTA M23 *Specification for road safety hardware*⁽¹¹⁾ and modified by appendix B. Barrier replacements shall, as far as practicable and as appropriate, utilise standard bridge barrier systems as detailed in NZTA M23⁽¹¹⁾ appendix B.

Side protection is defined as the rail or barrier systems by which road users are restrained from leaving the carriageway or structure in an uncontrolled manner. A risk management approach to side protection selection is described in appendix B, clause B3. Means of compliance with the requirements, which are mandatory for work funded by the NZTA, are given in clauses B4 to B6.

2.3 Waterway design

2.3.1 General

The waterway design of bridges and culverts shall comply with the requirements of the Austroads *Waterway design – A guide to the hydraulic design of bridges, culverts and floodways*⁽¹²⁾ (*Waterway design*) except as amended in 2.3.2 to 2.3.6.

2.3.2 Design floods

a. General

Waterway design⁽¹²⁾ provides recommendations for the recurrence intervals of the floods that should be used for the various aspects of design, but does not provide specific standards, instead leaving these to roading authorities to define. This clause details the NZTA's standards for the recurrence intervals of floods for waterway design.

In designing a waterway crossing, consideration shall be given to the type of structure, typically a bridge or culvert, and to the impact of the structure on the waterway and surrounding environment, due to the structure and its approaches.

b. Overall design of total waterway

In the design of a waterway crossing, the total waterway shall be designed to pass an average recurrence interval (ARI) flood corresponding to SLS 2 probability of exceedance given in table 2.1 (herein after referred to as the SLS 2 flood) without significant damage to the road and waterway structure(s). The regional council or other territorial authority responsible for the waterway shall also be consulted to determine if the waterway needs to be designed for a flood greater than the SLS 2 flood event.

2.3.2 continued

c. Design for climate change effects

Where it is practical and economic for a bridge or culvert structure to be retrofitted at a later date to accommodate increased flood flows arising from the effects of climate change, the structure need not initially be designed to accommodate increased flood flows arising from the effects of climate change. Where future retrofitting is not practical or does not reflect value for money, future climate change impacts shall be taken into account in the design. Assessment of the effects of climate change shall be based on the Ministry for the Environment manual *Climate change effects and impacts assessment*⁽¹³⁾ and other material based on more recent research published by reputable sources accepted by the road controlling authority. Where relevant, changes in sea level shall be assessed based on the Ministry for the Environment manual *Coastal hazards and climate change*⁽¹⁴⁾.

d. Serviceability limit state (SLS)

Level of serviceability to traffic: State highway waterway crossings shall pass floods of the ARI corresponding to the annual probability of exceedance for the SLS 2 flood event given in table 2.1 without interruption or disruption to traffic.

(ARI = 1/(annual probability of exceedance))

Damage avoidance: Bridges, major culverts and their approaches shall be designed to withstand the effects of a 25-year ARI flood without sustaining damage (SLS 1 given in table 2.1).

e. Ultimate limit state (ULS)

For the ultimate limit state, bridges and major culverts shall be designed for the effects of the ARI flood corresponding to the importance of the bridge and the annual probability of exceedance given in table 2.1. Collapse shall be avoided under the ULS event.

In situations where the design flood for the ultimate limit state will substantially overtop the bridge or major culvert structure, the intermediate stages in the flood height shall also be investigated and those stage heights that are most critical considered.

In situations where the bridge or major culvert is integral with adjacent flood protection works, the design flood for the ultimate limit state could be substantially larger than the design flood for the flood protection works. In estimating the design flood level for the ultimate limit state, cognisance therefore needs to be taken of the potential for such protection works to be overtopped and for a proportion of the peak flood flow to bypass the bridge or major culvert.

Similarly, where a bridge or a major culvert structure is sited on a floodplain with no upstream flood protection works present, estimation of the flood level for the ultimate limit state should take account of the potential for flood breakout upstream of the structure with consequential bypassing of the structure by a proportion of the peak flood flow.

2.3.3 Hydrology

a. Flood estimation methods

Where possible, design flood estimates shall be obtained from a flood frequency analysis of data from a hydrological gauging station in the vicinity of the bridge site. The hydrological flow record used for this analysis should preferably be at least 20 years long. The flood frequency analysis should use the probability analysis method that best fits the annual maxima series. Recognised probability analysis methods include the Gumbel, Log Pearson 3 and Generalised Extreme Value (GEV) methods. Probability analysis methods are described in the *Handbook of hydrology*⁽¹⁵⁾.

2.3.3 continued

If there is no hydrological information available in the vicinity of the bridge site, then a site on the same river should be used. The flood estimates should be scaled by the ratio of the catchment areas to the power of 0.8 as discussed in *Flood frequency in New Zealand*⁽¹⁶⁾, section 3:

$$Q_1/Q_2 = (A_1/A_2)^{0.8}$$

Where: Q = flood discharge

A = catchment area.

Where there is no hydrological gauging station present on the river, flood estimates shall be obtained by using one of the following two methods. These replace the methods outlined in section 3 of *Waterway design*⁽¹²⁾:

- The rational method - in which a peak flow of a selected ARI is estimated as a function of the average rainfall intensity of the same ARI.
- The regional method - *Flood frequency in New Zealand*⁽¹⁶⁾.

b. Rational method

The rational method is only applicable to small catchments because of its inability to account for the effects of catchment storage in attenuating the flood hydrograph. The recommended maximum size of the catchment to which the method should be applied is 25km² in urban catchments, and between 3 and 10km² for rural catchments. The rational method is described in *Australian rainfall and runoff*⁽¹⁷⁾ and the *Handbook of hydrology*⁽¹⁵⁾.

c. Regional method

Flood frequency in New Zealand⁽¹⁶⁾ is a regional method suitable for all rural catchments except those in which there is snow-melt, glaciers, lake storage or ponding. It should be used for rural catchments greater than 10km². It can also be used for rural catchments between 3km² and 10km² but should be checked against the rational method.

d. Estimation of the ultimate limit state design flood

The estimation of the ultimate limit state design flood shall be made based on a flood frequency analysis of available data as described in 2.3.3(a). Wherever possible the data shall be obtained from a hydrological flow gauging station at or near the site of the proposed bridge. It should be noted that the accuracy of design flood estimates depends on the length of flow record. Predictions beyond the 100-year ARI are not precise. Estimates for the ultimate limit state event shall be checked against gauging station data from other nearby catchments with similar hydrological characteristics.

If there is no hydrological flow data available at the bridge or major culvert site, then a site on the same river, or alternatively a gauging site on a nearby river with similar hydrological characteristics, should be used as described in 2.3.3(a). Data from more than one site should be used to ensure that a degree of smoothing of extreme values occurs.

2.3.4 Hydraulics

a. Freeboard for level of serviceability to traffic

When considering the level of serviceability to traffic required by 2.3.2(d), the freeboards given in table 2.4 shall be used.

Table 2.4: Freeboard allowance for the level of serviceability to traffic

Waterway structure	Situation	Freeboard	
		Measurement points	Depth (m)
Bridge	Normal circumstances	From the predicted flood stage to the underside of the superstructure	0.6
	Where the possibility that large trees may be carried down the waterway exists		1.2
Culvert (including major culverts)	All situations	From the predicted flood stage to the road surface	0.5

b. Waterways

In low-gradient silt- and sand-bed rivers determinations of Manning's n from sets of photographs, for example from *Roughness characteristics of New Zealand rivers*⁽¹⁸⁾, or from tables of values such as table 4.1 of *Waterway Design*⁽¹²⁾, should be taken as approximate only. Any possible backwater effects from downstream features should be investigated. Direct measurements should be obtained whenever possible.

In gravel-bed rivers, estimates of Manning's n shall be made using at least one formula, for example one of the 'rigid bed' formulae by Griffiths given in 2.3.4(c), as well as using *Roughness characteristics of New Zealand rivers*⁽¹⁸⁾. *Waterway design*⁽¹²⁾, table 4.1 is not appropriate to New Zealand rivers with gravel beds and shall not be used. If the formula in *Open channel flow*⁽¹⁹⁾ is used, a factor of 1.2 should be applied to the calculated values of Manning's n .

In all other rivers the estimation of Manning's n shall be the subject of a detailed hydraulic investigation.

c. Griffiths formulae

The Griffiths formulae noted above are taken from *Flow resistance in coarse gravel bed rivers*⁽²⁰⁾. The two 'rigid-bed' formulae recommended by Griffiths are:

$$1/\sqrt{f} = 1.33(R/d_{50})^{0.287}$$

$$1/\sqrt{f} = 1.98 \log_{10} (R/d_{50}) + 0.76$$

Where: f = Darcy-Weisbach friction factor

R = hydraulic radius

d_{50} = size for which 50% of the bed material is smaller.

is related to Manning's n by the following formula:

$$n = 0.113\sqrt{f}R^{1/6}$$

2.3.5 Scour

The estimation of scour should be based on *Bridge scour*⁽²¹⁾. This publication replaces section 6 of *Waterway design*⁽¹²⁾.

The pier scour depth induced by debris rafts such as described in 3.4.8(c) and as shown in figure 2.2 shall be estimated using an equivalent pier width a_d^* from the equations:

$$a_d^* = \frac{K_{d1}(TW)(L/y)^{K_{d2}} + (y - K_{d1}T)a}{y} \quad \text{for } L/y > 1.0$$

$$a_d^* = \frac{K_{d1}(TW) + (y - K_{d1}T)a}{y} \quad \text{for } L/y \leq 1.0$$

Where: K_{d1} = 0.79 for rectangular debris, 0.21 for triangular debris.

K_{d2} = -0.79 for rectangular debris, -0.17 for triangular debris.

L = length of debris upstream from pier face (m). L shall be taken as lying within the range $0.4W < L < 1.3W$.

y = depth of approach flow (m).

T = thickness of debris normal to flow (m), which shall be taken as the maximum rootball diameter of a tree likely to be transported by the river, (typically up to ~2m), or half the depth of the upstream flow, whichever is the greater, but not greater than 3.0m.

W = width of debris normal to flow (m), equal to the average of the span lengths either side of the pier, but not greater than the length of the largest tree likely to be transported by the river, or greater than 15m.

a = pier width (without debris) normal to flow (m).

2.3.6 Scour protection works

The security of the bridge or major culvert structure shall be ensured for all flood events of ARI up to that of the design ultimate limit state event specified in table 2.1 for the importance level of the structure. The design of scour protection works shall generally comply with the guidance provided in *Bridge scour*⁽²¹⁾. Where the use of gabions or reno mattresses are proposed to be used as scour protection works, the design shall comply with the design procedure given in appendix F of *Countermeasures to protect bridge piers from scour*⁽²²⁾.

Figure 2.2: Debris raft for pier scour assessment

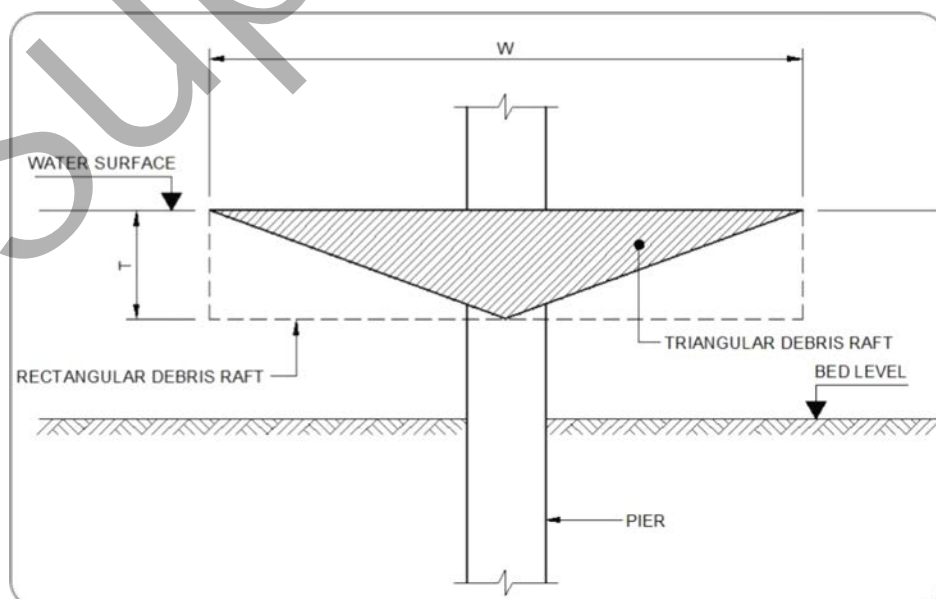

2.4 Site investigations

All structure sites shall be subject to appropriate geotechnical and geological investigations, sufficient to enable a geotechnical assessment to be undertaken to ensure that a safe, economical and practical design can be developed. The purpose of a geotechnical assessment is to:

- Identify and manage geotechnical risks that may influence the performance of the structure (eg liquefaction, slope instability).
- Provide geotechnical input into the design of the structure (eg soil loads, soil strength and stiffness).

The investigations shall establish the characteristics of the surface and subsurface soils and rocks, their behaviour when loaded and during construction, the nature and location of any faulting, and the groundwater conditions. Site conditions and materials affecting the construction of the structure shall also be determined.

Investigations normally consist of three phases:

- a. Preliminary investigations, consisting of compilation of general data, walkover survey and, where appropriate, some boreholes and laboratory tests.
- b. Detailed field investigations and laboratory tests, before final design.
- c. Investigations during construction, as appropriate.

Information obtained from site investigations shall be presented in an investigation report. Borehole logs, soil descriptions and testing shall comply with current practice, as presented in documents published by Standards New Zealand, New Zealand Geotechnical Society, British Standards Institution or similar. These investigations shall include interpretation of all available data by suitably qualified personnel and recommendations as to foundation and retaining structure types, cut and fill slopes and design parameters, and the need for proof testing, pilot drilling or other confirmatory investigation during construction.

2.5 Influence of approaches

The influence of approach embankments and cuttings on all types of structures (bridges, culverts, underpasses, subways and retaining structures) shall be considered, including:

- immediate gravity effects
- seismic effects
- long-term settlement effects
- loading from slope material, which may fall onto a deck.

The effects of approach settlement and stability on the riding characteristics, traffic safety, landscape treatments and performance of abutment components shall be considered.

2.6 Urban design

2.6.1 What is urban design?

Urban design is a design discipline that seeks to create desirable places for people to live, work and play. It involves the design and placement of buildings, roads, rail, open spaces, towns and cities. It focuses on the relationship between built form, land use and open space, natural features and human activity. Good urban design creates spaces that function well, have a distinctive identity and visual appeal.

As a signatory to the New Zealand Urban Design Protocol, the NZTA is committed to planning for, developing and promoting quality urban design. The challenge is to incorporate this commitment into all aspects of the NZTA's business. The NZTA's *HNO environmental and social responsibility manual*⁽²³⁾ requires that good urban design be integrated into all the NZTA's activities. This extends to the placement and design of bridges and other highway structures.

2.6.2 Aesthetics vs function

The design and placement of bridges and other highway structures that form part of the highway network influence the quality of the environment, both in terms of visual appearance and how these areas function. Urban design is concerned with both these dimensions of highway structures design.

The appearance or aesthetics of highway structures depends on their overall form and proportions, on the design coherence of their various components (abutment walls, side barriers, piers, soffit, etc) and on the quality of their detailing and finishes.

The functional aspects of highway structures that have an urban design dimension relate to how the structures support local movements by foot, cycles and vehicles and how they complement the scale and use of the surrounding land, buildings and spaces.

Further guidance on function and aesthetics of highway structures is provided by the NZTA's *Bridging the gap: Urban design guidelines*⁽²⁴⁾ and other references as noted in 2.6.4.

2.6.3 Urban design assessment for bridges and major retaining walls

New or replacement bridges and major retaining walls that are visible from surrounding communities, public open spaces or the highway itself, and bridges that are located in landscape sensitive areas (eg along scenic routes or in areas identified as outstanding landscape in the district plan) will require an urban design assessment or a landscape and visual assessment.

The urban design bridge assessment matrix in table 2.5 (also table 1 in appendix 5 of *Bridging the gap: Urban design guidelines*⁽²⁴⁾) is to guide urban design decision making in relation to bridges. The aim of the matrix is to assist in the high level assessment of the urban design considerations for a bridge. The matrix may also be used for major retaining walls.

The urban design assessment and landscape and visual assessment will then guide the subsequent stages of design. The assessment shall be undertaken once a preferred route option has been chosen and shall be reported in the preliminary structure options report and updated in the subsequent structure options report and structure design statement. On large or complex projects, the urban design considerations that have influenced the structure design and any design principles proposed to guide the detailed design must also be documented in the project's *Urban and landscape design framework*.

2.6.3 continued

It is expected that the urban design response for a specific structure will be appropriately calibrated to the outcome of the assessment. It is important that the design rationale for a structure design response can be communicated and understood. That urban design response should refer to the guidance in *Bridging the gap: Urban design guidelines*⁽²⁴⁾ and the other references noted in 2.6.4.

The matrix assessment will be undertaken by an appropriately qualified landscape architect or urban designer.

Both the visual and functional aspects of bridges and major retaining walls require consideration in terms of sections 6 and 7 of the Resource Management Act 1991⁽²⁵⁾ (RMA) when seeking a designation or resource consents. This typically involves an assessment of the structure under both the *Landscape and visual assessment of effects* and the *Urban design assessment of effects*. Both these technical reports underpin the *Assessment of environmental effects* for the project.

2.6.4 Appearance

Careful consideration shall be given, in line with *Bridging the gap: Urban design guidelines*⁽²⁴⁾, to the appearance or aesthetics of the structure.

Further guidance on the principles involved in designing for aesthetics may be obtained from the following references:

- NSW Roads and Maritime Services *Bridge aesthetics: Design guidelines to improve the appearance of bridges in NSW*⁽²⁶⁾.
- Fédération Internationale du Béton *Guidance for good bridge design*⁽²⁷⁾.

UK Highways Agency *The appearance of bridges and other highway structures*⁽²⁸⁾.

Table 2.5: Urban design bridge assessment matrix

Urban design bridge assessment matrix <i>Comment in each column for each bridge location (there may be more than 2 locations on any section of roading project - add further columns as required) as to the level of importance and a brief explanatory comment</i>				
Assessment matter	Explanation as to importance for urban design attention	Measure types that may be used to gain an understanding of importance	Location A	Location B
Underlying natural environment	Does the context have underlying characteristics that will be affected by the bridge or suggest a certain form of bridge response? For example consider topography, natural features such as vegetation, ecology or landscape	Planning documents (district or regional plans) Landscape assessments Urban design contextual analysis Preliminary assessment undertaken as part of project		
Circulation	Is there an existing or likely future (eg from planned urban development) circulation pattern or network that will be affected by the bridge or suggest a certain form of bridge response? For example consider what level of use occurs (or may be planned to occur) in the bridge location? Demographic profile also of interest as older people/children more vulnerable to level changes/safety and less likely to have access to a vehicle.	LAMS (Local Area Movement Surveys) Counts including school travel plans Network monitoring Demographic profile for area Urban growth plans		
Activities	Are the existing or likely future (eg from planned development) activities in the vicinity affected by the bridge or suggest a certain form of bridge response? For example consider access to existing properties, accessibility to activities of local importance such as schools.	District Plan Urban growth plans, transport strategies Urban design contextual analysis Preliminary assessment undertaken as part of project		
Built form	Is the existing or likely future (eg from planned development) urban form affected by the bridge or suggest a certain form of bridge response? For example consider whether the bridge is at a key nodal point in the network (eg at an interchange, town centre, key turn off)? What is the fit with the scale of the built form in the area?	Network analysis (transportation plans) Urban growth plans Urban design contextual analysis		
Amenity	Is the location amenity affected by the bridge or suggest a certain form of bridge response? For example consider how many people will view the bridge- ie live near the location or pass by frequently? What is the visibility of the bridge from the point of view of the highway user? What is effect on shading or tranquillity of the location?	Inter visibility assessment Landscape assessments Urban design contextual analysis Preliminary assessment undertaken as part of project		

2.7 Special studies

Special studies are required when:

- a structural form or method of construction is proposed which is not covered by accepted standards or design criteria (eg to determine design parameters, safety factors or durability)
- non-conventional materials are to be applied, the technology of which is still undergoing significant development (conventional materials include concrete, steel, timber, engineered soils, natural soils, geogrid reinforcements and geotextiles)
- site-specific studies are undertaken to define the exposure classification associated with durability requirements or the seismic hazard spectra for earthquake response analysis.

Special studies shall be documented in complete reports, included as appendices to the structure options report or structure design statement. This documentation shall include, as appropriate:

- the source of all data
- demonstration that the study has provided appropriate evaluation of the particular structural performance being investigated
- reference to relevant national and international standards and guidelines, and published peer reviewed papers
- comparison of the results with other data
- a description of the analytical methods used
- details of the organisation/individual who has undertaken the special study

a brief outline of the experience and capability of the agency and personnel undertaking the special study.

2.8 References

- (1) NZ Transport Agency (2016) *ZH/MS/01 Safety in design minimum standard for road projects*. Wellington.
- (2) Parliamentary Counsel Office (1992) *Building Regulations 1992. Schedule 1 The building code*. Wellington.
- (3) NZ Transport Agency (2016) *Highway structures design guide*. Wellington.
- (4) Standards Australia and Standards New Zealand jointly AS/NZS 1170.0:2002 *Structural design actions*. Part 0 General principles.
- (5) NZ Transport Agency (2009) *Procurement manual: for activities funded through the National Land Transport Programme*, Procurement manual tools, Latest values for 1991 infrastructure cost indexes. Last accessed 28 September 2018
<www.nzta.govt.nz/assets/resources/procurement-manual/docs/latest-values-for-1991-infrastructure-cost-indexes-new-presentation.xls>.
- (6) NZ Transport Agency (2013) *One Network Road Classification*. Last accessed 28 September 2018
<www.nzta.govt.nz/roads-and-rail/road-efficiency-group/onrc/>
- (7) NZ Transport Agency (2013) *Tables of state highways in each ONRC classification category*. Last accessed 28 September 2018
<www.nzta.govt.nz/assets/Road-Efficiency-Group-2/docs/state-highways-by-category.pdf>.
- (8) Standards New Zealand NZS 3101.1&2:2006 *Concrete structures standard*. (Incorporating Amendment No. 3: 2017)
- (9) American Association of State Highway and Transportation Officials (1999) *Guide specification for design and construction of segmental concrete bridges*, 2nd edition, with 2003 interim revisions. Washington DC, USA.
- (10) Standards Australia and Standards New Zealand jointly AS/NZS 3845.1:2015 *Road safety barrier systems and devices*. Part 1 Road safety barrier systems.
- (11) NZ Transport Agency (2018) *NZTA M23 Specification for road safety hardware*. Wellington. (In prep.)
- (12) Austroads (1994) *Waterway design – A guide to hydraulic design of bridges, culverts and floodways*. Sydney, NSW, Australia. Superseded.
- (13) Ministry for the Environment (2008) *Climate change effects and impacts assessment: A guidance manual for local government in New Zealand – 2nd edition*. Wellington.
- (14) Ministry for the Environment (2008) *Coastal hazards and climate change: A guidance manual for local government in New Zealand – 2nd edition*. Wellington.
- (15) Maidment DR (1993) *Handbook of hydrology*. McGraw - Hill Inc. New York, NY, USA.
- (16) McKerchar AI and Pearson CP (1989) *Flood frequency in New Zealand*. Publication No. 20, Hydrology Centre, Department of Scientific and Industrial Research, Christchurch.

- (17) Institution of Engineers, Australia (1987) *Australian rainfall and runoff: A guide to flood estimation*, Vol. 1, revised edition 1987 (reprinted edition 1998). Barton, ACT, Australia.
 - (18) Hicks DM and Mason PD (1998) *Roughness characteristics of New Zealand rivers*. National Institute of Water and Atmospheric Research, Water Resources Publications, LLC. Highlands Ranch, CO, USA.
 - (19) Henderson FM (1966) *Open channel flow*. MacMillan, New York, NY, USA.
 - (20) Griffiths GA (1981) *Flow resistance in coarse gravel bed rivers*. Proc. ASCE *Journal of the Hydraulics Division*, Vol. 107, No. 7, July 1981, pp. 899-918.
 - (21) Melville BW and Coleman SE (2000) *Bridge scour*. Water Resources Publications, LLC. Highlands Ranch, CO, USA.
 - (22) Transportation Research Board (2007) *Countermeasures to protect bridge piers from scour*. National Cooperative Highway Research Program report 593, Washington DC, USA.
 - (23) NZ Transport Agency (2012) SP/M/023 *HNO environmental and social responsibility manual*. Wellington.
 - (24) NZ Transport Agency (2013) *Bridging the gap: Urban design guidelines*. Wellington.
 - (25) Parliamentary Counsel Office (1991) *Resource Management Act 1991*. Wellington.
 - (26) Roads and Maritime Services (2012) *Bridge aesthetics: Design guidelines to improve the appearance of bridges in NSW*. Sydney, NSW, Australia.
 - (27) Fédération Internationale du Béton (2000) *Guidance for good bridge design*. Lausanne, Switzerland.
 - (28) Highways Agency (1996) *The appearance of bridges and other highway structures*. HMSO, London, United Kingdom.
-

3.0 Design loading

In this section

	Section	Page
3.1	Introduction	3-2
3.2	Traffic loads - gravity effects	3-2
3.3	Traffic loads - horizontal effects	3-6
3.4	Loads other than traffic	3-7
3.5	Combination of load effects	3-20
3.6	References	3-23

3.1 Introduction

All structures shall be designed for the following loads, which shall be considered to act in various combinations as set out in 3.5, except for lightly trafficked rural bridges - refer to appendix D.

3.2 Traffic loads - gravity effects

3.2.1 General

Traffic loading shall be HN-HO-72. A detailed description of this loading and its application is given below. The loads described shall be used for design of all members from deck slabs to main members and foundations.

In 2004 the design traffic loading, HN-HO-72, was modified by the introduction of a 1.35 load factor applied to normal live load in the serviceability limit state (SLS) load combinations.

In 2013 the NZTA commissioned research report RR 539 *A new vehicle loading standard for road bridges in New Zealand*⁽¹⁾ was published. Subsequent to this research a review of vehicle live load models, load combinations and load factors to be used has commenced. Until this work is completed and any revisions published, the current provisions of the *Bridge manual* shall be followed.

3.2.2 Loads

a. HN (normal) loading

An element of normal loading represents a single stream of legal traffic and is the load applied to a 3m-wide strip of deck, running the entire length of the structure. It is shown diagrammatically in figure 3.1. The element consists of two parts.

The first is a uniform load of 3.5kN/m², 3m wide, which may be continuous or discontinuous over the length of the bridge, as necessary to produce the worst effect on the member under consideration.

In addition to the uniform load, a pair of axle loads of 120kN each, spaced at 5m, shall be placed to give the worst effect on the member being designed. Only one pair of axle loads shall exist in each load element, regardless of the length of bridge or number of spans. For design of deck slabs, the wheel contact areas shown shall be used, but for design of other members, such detail is unnecessary and point or line loads may be assumed.

b. HO (overload) loading

An element of overweight loading is also shown diagrammatically in figure 3.1. It consists of, firstly, the same uniform load as described above. In addition, there is a pair of axle loads of 240kN each, spaced at 5m. In this case, there are two alternative wheel contact areas, and the one that has the most adverse effect on the member being considered shall be used.

Figure 3.1: HN-HO-72 traffic loading

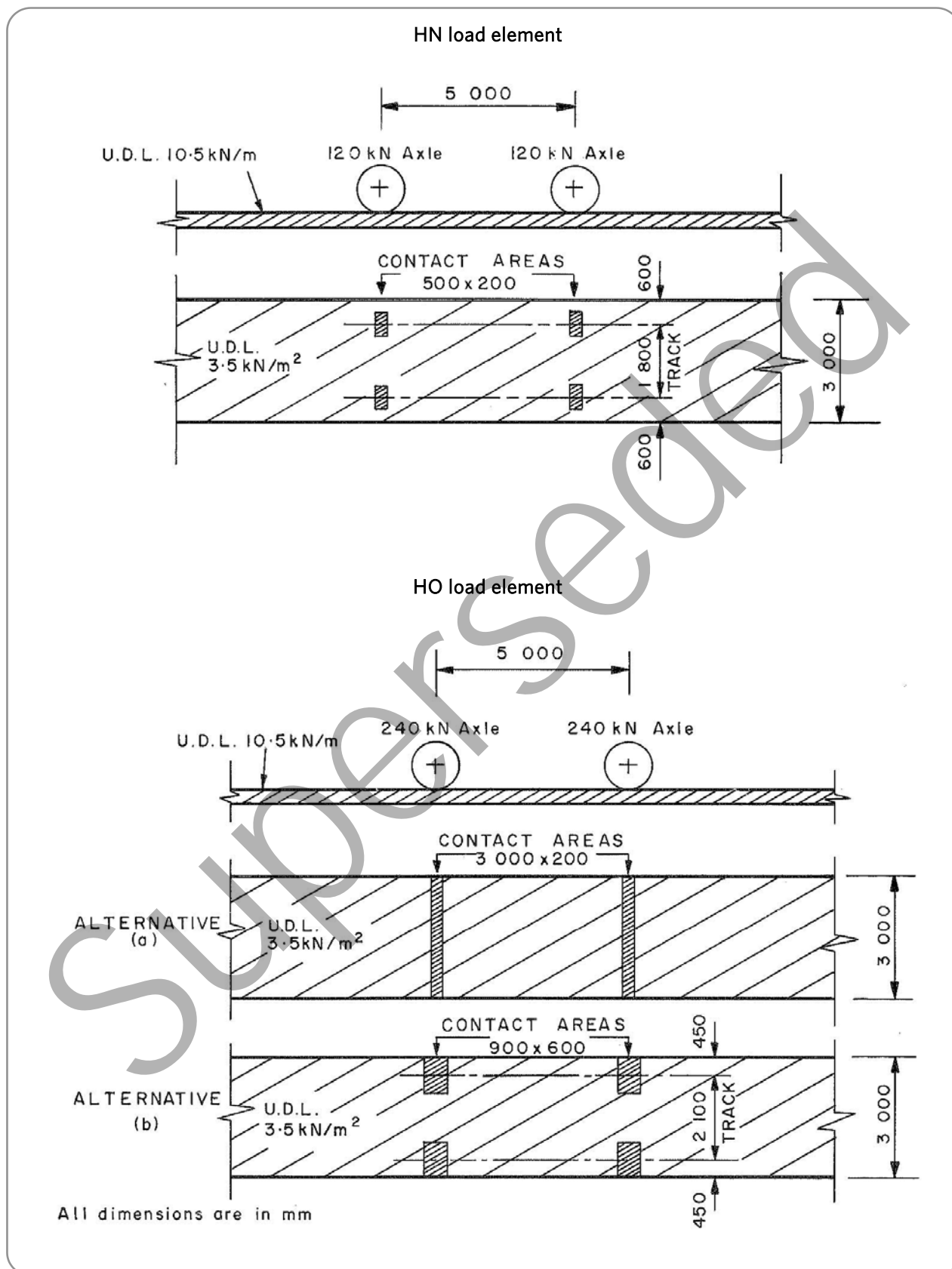

3.2.3 Transverse load position

- a. The above load elements shall be applied to an area defined as the carriageway. The carriageway includes traffic lanes and shoulders. Raised or separated footpaths, cycle tracks or medians shall not be included in the carriageway unless the possibility of future reconfiguration of the carriageway is identified as a design requirement. On bridges the carriageway is bounded by either the face of a kerb or the face of a guardrail or other barrier.
- b. The carriageway shall be divided into a number of load lanes of equal width as follows:

Width of carriageway	Number of load lanes
Less than 6m	1
6m but less than 9.7m	2
9.7m but less than 13.4m	3
13.4m but less than 17.1m	4
17.1m but less than 20.8m	5

Note: Load lanes as defined above are not to be confused with traffic lanes as physically marked on the road surface.

- c. For global effects, typically the design of main members, the load elements shall be applied within each load lane as defined above, but may have as much eccentricity within the lane as their width of 3m allows. Even if the number of traffic lanes as finally marked on the bridge will be different from that obtained from the table above, the number tabulated shall be used for design purposes.
- d. For local effects, typically the design of deck slabs and their immediate supporting members (deck stringers and transoms etc), load elements are not restricted by the lanes as above but shall be placed anywhere within the carriageway, at such spacing as will give the worst effect, but not less than 3m centres transversely.
- e. In order to represent a vehicle which has penetrated the guardrail, handrail or other barrier, or has mounted the kerb, if any, any slab and supporting members outside the carriageway shall be checked under HN wheel loads factored by the dynamic load factor. The wheels shall be positioned with their outer edge at the outer edge of the slab or kerb or anywhere inboard of that line. This may be treated as a load combination 4 (overload).

3.2.4 Combination of traffic loads

Two combinations of traffic loads shall be used for ultimate and serviceability limit state design purposes:

- a. Normal live load

In this combination, as many elements of HN loading shall be placed on the bridge as will give the worst effect on the member being considered, complying with the rules for positioning set out in 3.2.3.

- b. Overload

In this combination, any one element of HN loading in the live load combination shall be replaced by an element of HO loading, chosen so as to give the most adverse effect on the member being considered.

3.2.4 continued

To allow for the improbability of concurrent loading, where appropriate, total normal live loading may be multiplied by a factor varying according to the number of elements (ie lanes loaded) in the load case, thus:

Number of load elements (lanes loaded)	Reduction factor
1	1.0
2	0.9
3	0.8
4	0.7
5	0.6
6 or more	0.55

For overloads, the reduction factor for the HO load element shall be taken as 1.0. For additional load elements (lanes loaded), the reduction factors shall be as specified above (ie a reduction factor of 1.0 for the first additional load element reducing thereafter).

For the design of individual structural members, the number of load lanes that are loaded, applied in conjunction with the corresponding reduction factor, shall be selected and positioned to maximise the load effect on the structural member under consideration.

3.2.5 Dynamic load factor

Normal live load and overload shall be multiplied by the dynamic load factor applicable to the material and location in the structure of the member being designed.

The dynamic load factor for use in the design of all components which are above ground level shall be taken from figure 3.2.

The dynamic load factor for use in the design of components which are below ground level shall be 1.0, to allow for the fact that vibration is damped out by the soil, except that for top slabs of culvert type structures, the dynamic load factor shall be reduced linearly with depth of fill, from 1.30 for zero fill to 1.00 for 1m of fill.

3.2.6 Fatigue

The loading used in the fatigue assessment of steel bridges shall at least represent the expected service loading over the design life of the structure, including dynamic effects. This should be simulated by a set of nominal loading events described by the distribution of the loads, their magnitudes, and the number of applications of each nominal loading event.

A standard fatigue load spectrum for New Zealand traffic conditions is not available, although one is in development following on from the NZTA commissioned research report RR 547 *Fatigue design criteria for road bridges in New Zealand*⁽²⁾.

In the interim, steelwork may be designed for the effects of fatigue in accordance with AS 5100.6-2004 *Bridge design part 6 Steel and composite construction*⁽³⁾ as modified by the New Zealand Heavy Engineering Research Association document *Recommended draft fatigue design criteria for bridges version 3*⁽⁴⁾. The draft fatigue design criteria shall be amended so that the fatigue design traffic load is applied in each marked traffic lane rather than the design lanes.

In a case where fatigue details significantly influence the design, an appropriate loading spectrum shall be developed, taking account of current and likely future traffic.

3.2.6 continued

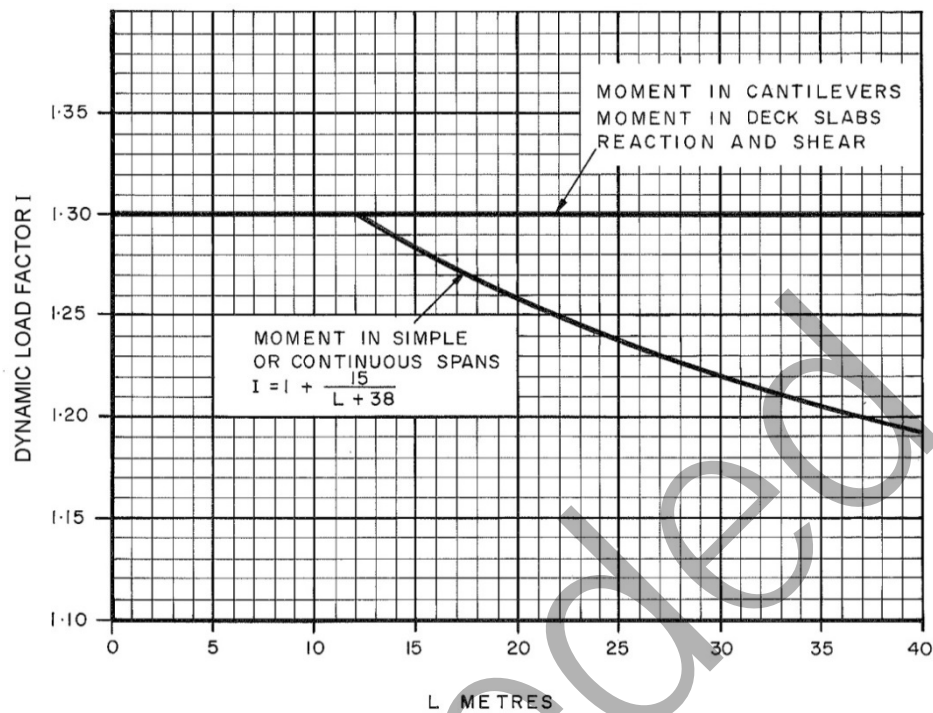
Figure 3.2: Dynamic load factor for components above ground level and for bearings

L is the span length for positive moment and the average of adjacent span lengths for negative moment.

3.2.7 Live loading due to construction vehicles and plant

Where sections of a project are to be utilised as haul routes for the project construction and new structures are to be subjected to loading effects imposed on them by construction vehicles and plant that exceed those imposed by the *Bridge manual* specified design HN (normal) live loading applied in as many lanes as produces the worst design loading effect on elements of the structures, the structures shall be designed for the loading effects imposed by the construction vehicles and plant treated as normal live loading.

Where construction vehicles and plant are to traverse over a new structure or alongside a new earth retaining structure and will impose on that structure loading effects exceeding those imposed by the design normal live loading applied to the design of the structure, the passage of such vehicles shall be subject to NZTA's permit procedures for overweight vehicles.

3.3 Traffic loads - horizontal effects

3.3.1 Braking and traction

For local effects, a horizontal longitudinal force, equal to 70% of an HN axle load, shall be applied across the width of any load lane at any position on the deck surface to represent a skidding axle.

For effects on the bridge as a whole, a horizontal longitudinal force shall be applied at deck surface level in each section of superstructure between expansion joints. The magnitude of the force shall be the greater of two skidding axle loads as above, or 10% of the live load which is applied to the section of superstructure, in each lane containing traffic headed in the same direction. In some cases, eg on the approach to an intersection or for a bridge on a grade, it may be appropriate to allow for a greater force.

Consequent displacement of the structure shall be allowed for.

3.3.2 Centrifugal force

A structure on a curve shall be designed for a horizontal radial force equal to the following proportion of the live load. The reduction factors of 3.2.4 shall be applied but the dynamic load factor of 3.2.5 shall not be applied.

$$C = 0.008S^2/R$$

Where: C = centrifugal force as a proportion of live load

S = design speed (km/h)

R = radius (m)

The force shall be applied 2m above the road surface level, but the consequent variation in wheel loads need not be considered in deck design. Consequent displacement of the structure shall be allowed for.

3.4 Loads other than traffic

3.4.1 Dead load

This shall consist of the weight of the structural members and any other permanent load added, or removed before the structural system becomes complete. When calculating the weight of concrete members, care shall be taken to use a density appropriate to the aggregates available in the area, plus an allowance for embedded steel.

3.4.2 Superimposed dead load

This shall consist of all permanent loads added after the structural system becomes complete. It shall include handrails, guardrails, barriers, lamp standards, kerbs, services and road surfacing. Surfacing shall be allowed for at 1.5kN/m² whether the intention is to surface the bridge immediately or not. Where a levelling course is applied, the weight of the levelling course shall be in addition to the 1.5kN/m² superimposed dead load allowance for bridge deck surfacing.

An allowance shall be made for future services in addition to the weight of actual services installed at the time of construction. A minimum allowance of 0.25kN/m² for future services shall be applied as a uniformly distributed load over the full width and length of the bridge deck.

3.4.3 Earthquake

The design shall allow for the effects of earthquakes by considering:

- the possibility of earthquake motions in any horizontal direction
- the potential effects of vertical earthquake motions
- the available structure ductility.

The magnitude of the force due to the inertia of the structure, and the required structure ductility, shall be obtained from section 5. Earthquake effects on ground and soil structures (eg embankments, slopes and independent retaining walls) are specified in section 6. The earthquake increment of soil pressure acting on a structure shall be treated as an earthquake load when combining loads into load combinations as specified in 3.5.

In considering the stability and displacement of ground and soil structures (including earth retaining walls), unweighted peak ground accelerations, as specified in section 6, shall be used as the basis for deriving the earthquake loads acting.

In considering the strength design of structures (including locked-in structures and retaining walls), magnitude weighted peak ground accelerations, as specified in section 5, shall be applied in deriving the earthquake increment of soil pressure acting on the structure.

3.4.4 Shrinkage, creep and prestressing effects

The effects of shrinkage and creep of concrete, and shortening due to prestressing shall be taken into account. Transmission of horizontal forces from superstructure to substructure by bearing restraint shall be allowed for.

In the derivation of forces imposed on the structure due to these effects, consideration shall be given to the likelihood of cracking occurring in reinforced concrete piers and the influence this will have on their section rigidity. An appropriately conservative assessment of the forces to be adopted for the design of the structure shall therefore be made. The effects of creep in the pier in reducing the forces may be taken into account.

In composite structures, differential shrinkage and creep between elements shall be allowed for.

The secondary effects of shrinkage, creep and prestressing shall be allowed for in continuous and statically indeterminate structures.

Appropriate load factors for the effects of shrinkage and creep (SG) and prestressing (PS) are given in tables 3.1 and 3.2.

3.4.5 Wind

- a. Wind load shall be applied to a bridge in accordance with the principles set out in BS 5400-2 *Steel concrete and composite bridges* part 2 Specification for loads⁽⁵⁾ clause 5.3 contained within BD 37 *Loads for highway bridges*⁽⁶⁾ appendix A, giving consideration to wind acting on adverse and relieving areas as defined in clause 3.2.5 of that standard. For footbridges with spans exceeding 30m for which aerodynamic effects may be critical, the principles forming the basis of BD 49 *Design rules for aerodynamic effects on bridges*⁽⁷⁾ shall be applied.
- b. The design gust wind speeds acting on adverse areas of a bridge without live load being present, for the ultimate and serviceability limit states shall be calculated in accordance with AS/NZS 1170.2 *Structural design actions* part 2 Wind actions⁽⁸⁾ clauses 2.2 and 2.3 for the annual probability of exceedance corresponding to the importance of the bridge as defined in 2.1.3.

The design gust wind speeds acting on relieving areas of a bridge without live load being present shall be derived from the following equation:

$$V_r = \frac{V_d S_c T_c}{S_b T_g}$$

Where: V_r = design gust wind speed acting on relieving areas

V_d = design gust wind speed acting on adverse areas

S_c, T_c, S_b and T_g are factors defined in and derived from BS 5400-2⁽⁵⁾ clause 5.3, contained within BD 37⁽⁶⁾ appendix A.

The height of a bridge shall be measured from ground level or minimum water level to the deck level.

For the case where wind load is applied to a bridge structure and live load (including pedestrian loading) on the bridge, as defined in (a) above, the maximum site gust wind speed acting on adverse areas shall be the lesser of 37m/s and V_d m/s as specified above, and the effective coexistent value of wind gust speed acting on parts affording relief shall be taken as the lesser of $37 \times S_c / S_b$ m/s and V_r m/s, as specified above.

- c. Wind forces shall be calculated using the method of BS 5400-2⁽⁵⁾ clauses 5.3.3 to 5.3.6, contained within BD 37⁽⁶⁾ appendix A.

3.4.6 Temperature effects

Temperature effects shall be allowed for in the design under the following load cases, which shall be treated as able to act separately or concurrently:

a. Overall temperature changes

Allowance shall be made for both forces and movements resulting from variations in the mean temperature of the structure, as below:

For steel structures	±25°C
For concrete structures	±20°C

In the derivation of forces imposed on the structure due to these effects, consideration shall be given to the likelihood of cracking occurring in reinforced concrete piers and the influence this will have on their section rigidity. An appropriately conservative assessment of the forces to be adopted for the design of the structure shall therefore be made.

Figure 3.3: Temperature variation with depth

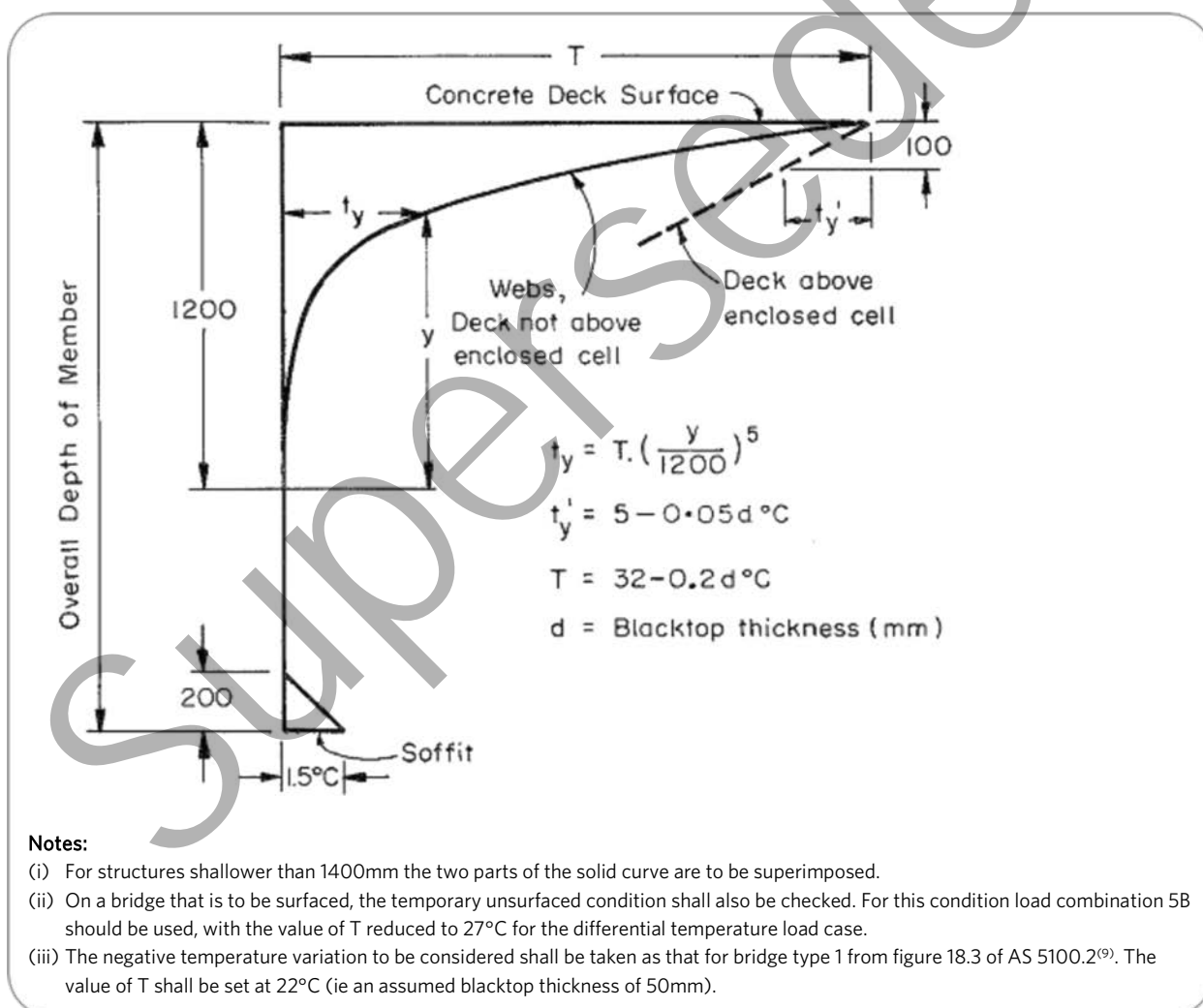

3.4.6 continued

b. Differential temperature change

Allowance shall be made for stresses and movements, both longitudinal and transverse, resulting from temperature variation through the depth of the structure shown in figure 3.3. The effects of vertical differential temperature gradients shall be considered for both positive differential temperature conditions, where solar radiation has caused a gain in the top surface temperature, and negative temperature differential conditions, where re-radiation of heat from the section or snow fall results in a relatively low top surface temperature.

The criteria shall be used for all structural types and all materials except timber.

In the case of a truss bridge, the temperature variation shall be assumed to occur only through the deck and stringers, and any chord members attached to the deck, and not through web members or chord members remote from the deck.

For analysis of reinforced concrete members under differential temperature, the properties of the cracked section shall be used.

3.4.7 Construction and maintenance loads

Allowance shall be made for the weight of any falsework or plant that must be carried by the structure because of the anticipated methods of construction and maintenance. This does not obviate the necessity of checking, during construction and maintenance, the capacity of the structure for the contractor's actual equipment.

All elements of structures that will be subjected to construction and maintenance loading (eg the bottom flange of box girders) shall be designed for a minimum access loading of 1.5kN/m², which need not act concurrently with traffic live loads.

3.4.8 Water pressure

Loads due to water pressure shall be applied to a bridge in accordance with AS 5100.2 *Bridge design* part 2 Design loads⁽⁹⁾ clause 16 except as modified below:

a. Modification to AS 5100.2⁽⁹⁾ clause 16.3.1

In place of the 2000-year average recurrence interval (ARI) specified, the upper limit of the ultimate limit state ARI shall be taken as the inverse of annual probability of exceedance for the ultimate limit state given in table 2.1 of this manual.

Where the critical design condition occurs at an ARI of less than the upper limit of the ultimate limit state ARI_1 , the ultimate limit state load factor (γ_{FL}) shall be taken as:

$$\gamma_{FL} = 2 - \left(\frac{1}{\log\left(\frac{ARI_1}{20}\right)} \right) \times \left(\log\left(\frac{ARI}{20}\right) \right)$$

b. Modification to AS 5100.2⁽⁹⁾ clause 16.3.2

In place of the serviceability limit state design floods specified by AS 5100.1 *Bridge design* part 1 Scope and general principles⁽¹⁰⁾ clause 11.1, the ARI of the serviceability limit state design flood shall be taken as the inverse of the annual probability of exceedance for the relevant serviceability limit state (SLS 1 or SLS 2) given in table 2.1 of this manual.

c. Modification to AS 5100.2⁽⁹⁾ clause 16.6.1

The depth of the debris mat varies depending on factors such as catchment vegetation, available water flow depth and superstructure span. In the absence of more accurate estimates, the minimum depth of the debris mat shall be half the water depth, but not less than 1.2m and not greater than 3m.

Both triangular shaped and rectangular shaped debris mats shall be considered (see 2.3.5 and figure 2.2 of this manual).

3.4.9 Groundwater on buried surfaces	<p>Groundwater pressures shall be based on the groundwater levels and pressures measured from an appropriate programme of site investigations, with allowance for seasonal, long term and weather dependent fluctuations, and considering the reliability and robustness of any drainage measures incorporated in the design. Consideration shall also be given to flood situations and also incidents such as possible break in any water pipes or other drainage services.</p> <p>The groundwater pressure shall correspond to not less than the groundwater level with a 1/50 annual probability of exceedance. Conservatively the groundwater level may be taken as being at the ground surface provided that artesian or sub-artesian pressures are not present.</p>
3.4.10 Water ponding	<p>The load resulting from water ponding shall be calculated from the expected quantity of water that can collect when primary drainage does not function.</p>
3.4.11 Snow	<p>Snow loading need only be considered at the ultimate limit state for footbridges.</p> <p>The design snow load shall be determined from AS/NZS 1170.3 <i>Structural design actions</i> part 3 Snow and ice actions⁽¹⁾ for the annual probability of exceedance corresponding to the importance of the footbridge as defined in 2.1.3.</p>
3.4.12 Earth loads	<p>a. Earth loads shall include horizontal static earth pressure (active, at-rest, passive and compaction), horizontal earthquake earth pressure, vertical earth pressure and surcharge pressure. It also includes negative skin friction (downdrag) loads on piles.</p> <p>b. Earth retaining members shall be designed for static earth pressure plus either live load surcharge where appropriate or earthquake earth pressure in accordance with 6.2.4, whichever is more severe. Water pressure shall also be allowed for unless an adequate drainage system is provided.</p> <p>For global analysis (of the whole structure), live load effects may be assumed equal to those of a surcharge pressure; in the case of HN (normal) traffic loading, 12kPa, and in the case of HO (overload) traffic loading, 24kPa.</p> <p>For localised wheel load or other point load effects acting on retaining walls a method based on Boussinesq's equations or similar appropriate method shall be applied.</p> <p>In calculating static earth pressures, consideration shall be given to the influence of wall stiffness, foundation and tie-back stiffness (where appropriate) and the type, compaction and drainage provisions of the backfill. Active, at-rest or passive earth pressure shall be used as appropriate.</p> <p>In some structures, for example concrete slab frame bridges, an increase in static earth pressure reduces the total load effect (eg moment) in some positions in the structure. When calculating the total load effect at those positions, a maximum of half the benefit due to static earth pressure shall be used in the load combination. Loads on foundations due to downdrag (or negative friction) and to plastic soil deformation, shall be included.</p> <p>c. In combining load effects, as specified in 3.5, the various loads transmitted by the soil shall be treated as follows:</p> <ul style="list-style-type: none"> - Horizontal static earth pressure, vertical earth pressure, and negative skin friction shall be treated as earth pressures (EP). - Surcharge simulation of HN loading in some or all lanes shall be treated as a traffic live load (LL). - Surcharge simulation of HO loading in one lane with HN loading in some or all other lanes shall be treated as a traffic overload (OL).

3.4.12 continued

- The earthquake increment of soil pressure (ΔP_E) shall be treated as an earthquake load (EQ).
 - Pressure due to water shall be treated as a ground water loading (GW).
- d. The effects of earthquake induced site instability, differential movements and liquefaction shall be considered as specified in section 6.

3.4.13 Loads on kerbs, guardrails, barriers and handrails

Kerbs, guardrails, barriers and handrails shall be designed in accordance with appendix B.

3.4.14 Loads on footpaths and cycle tracks

- a. A footpath or cycle track not considered as part of the carriageway in accordance with 3.2.3(a) shall be designed for a uniformly distributed load as follows:
- When traffic loads are not considered in the same load case, 5.0kPa.
 - When traffic loads are considered in the same load case, between the limits of 1.5 and 4.0kPa as given by the expression $5.0 - S/30$, where S, the loaded length in metres, is that length of footpath or cycle track which results in the worst effect on the member being analysed.

The structure shall also be checked for an overload case consisting of the HN wheel loads in accordance with 3.2.3(e).

- b. A footpath or cycle track considered as part of the carriageway, in accordance with 3.2.3(a), shall also be designed for the loads in (a) in conjunction with traffic loading on the remaining carriageway width.
- c. A footpath or cycle track on a highway bridge positioned out of reach of the traffic, eg underneath the carriageway, shall be designed as in (a) but without the overload.
- d. A foot or cycle track bridge without traffic shall be designed for a uniformly distributed load between the limits of 2.0 and 5.0kPa, as given by the expression $6.2 - S/25$ where S is as defined in (a).
- e. In all cases where there is a likelihood of crowd loading, the maximum value of 5.0kPa should be considered, regardless of the loaded length. Examples are access to a sports stadium or where the bridge could become a vantage point to view a public event.
- f. Where a footpath or cycle track is able to be accessed by horses or stock, the structure shall also be designed for a point loading of 8.0kN acting on a 100mm x 100mm square applied anywhere on the accessible areas. The cover concrete to embedded ducts and covers to ducts formed in footpaths and cycle tracks shall be designed to withstand this loading.

3.4.15 Vibration

All highway bridges shall be checked for the effects of vibration due to traffic loads. The criteria below shall be complied with for bridges carrying significant pedestrian or cycle traffic, and those where vehicles are likely to be stationary for a significant portion of the time (ie near intersections with, or without, traffic signals). Other bridges should comply with the criteria where economically justifiable.

The maximum vertical velocity during a cycle of vibration due to the design load shall be limited to 0.055m/s. The design load for this purpose shall be taken as the two 120kN axles of one HN load element. The following procedure is acceptable, but may be replaced by a rigorous analysis if desired:

3.4.15 continued

- a. Calculate the natural frequency of vibration. For a simply supported, rectangular in plan, span of prismatic section, the natural frequency is given by:

$$f = \frac{\pi}{2L^2} \sqrt{\frac{EIg}{w}} \text{ Hz}$$

Where: f = natural frequency (Hz)

E = modulus of elasticity (N/m²)

I = second moment of area of the whole cross-section (m⁴)

g = acceleration due to gravity (9.81 m/sec²)

w = dead and superimposed dead load per unit length (N/m)

L = span (m)

For two and three span continuous bridges, standard solutions are available, eg *Bridge vibration study*⁽¹²⁾. In other cases, including the cases of skewed bridges, curved bridges, and wide bridges where flexibility in the lateral direction is important, a computer analysis may be required.

- b. Calculate the amplitude of vibration:

$$a = k\delta$$

Where: a = Amplitude of vibration

k = 0.4 where $f > 4\text{Hz}$

= 0.75 where $f < 4\text{Hz}$

δ = deflection at midspan due to static design live load

In calculating δ , the two axles of the HN load may be assumed to be applied together at midspan.

- c. Calculate velocity from:

$$v = 2\pi fa$$

Pedestrian and cycle bridges shall conform to the requirements of BS 5400-2⁽⁵⁾ appendix B contained within BD 37⁽⁶⁾ appendix A. Should the fundamental frequency of horizontal vibration of the bridge be found to be less than the 1.5Hz limit specified, a dynamic analysis to derive maximum horizontal acceleration may be undertaken in accordance with clause NA.2.44.7 of NA to BS EN 1991-2 *UK National Annex to Eurocode 1. Actions on structures part 2 Traffic loads on bridges*⁽¹³⁾.

For pedestrian and cycle bridges with spans exceeding 30m, where aerodynamic effects may be critical, wind vibration effects as detailed in BD 49⁽⁷⁾ shall be considered.

3.4.16 Settlement, subsidence and ground deformation

Horizontal and vertical forces and displacements induced on or within the structure as a result of settlement, subsidence or ground deformation in the vicinity of the structure or approach embankment shall be taken into account.

Where there is potential for subsidence of the ground (such as due to groundwater changes, mining or liquefaction) the effects of this on the structures and the performance requirements for the road link shall be taken into consideration in the development and design of appropriate mitigation measures.

3.4.17 Forces locked-in by the erection sequence

Locked-in forces in a structure that are caused by the erection sequence shall be allowed for. These may arise due to the weight of formwork, falsework and construction equipment acting on structural elements as they are built in.

The secondary effects of prestressing shall be considered as specified in 3.4.4.

3.4.18 Collision loads

a. General

Structures shall be designed to resist collision loads where:

- piers, abutments or superstructures of bridges over roads, railways or navigable rivers are located such that collisions are possible
- retaining walls are located such that collisions are possible and collision could result in the wall collapsing, partially or fully, onto the carriageway or endangering adjacent property
- bridge or other structure components at or above road level could be struck by vehicles.

The intention behind these requirements is that the overall structural integrity of the structure should be maintained following a collision but that local damage to a part of the structure support or deck can be accepted.

In some circumstances, reduced collision loads may be considered if an appropriate protective barrier system is provided, collisions are considered highly improbable or the structure has sufficient redundancy to prevent collapse in the event of a collision.

Note that structure elements may be considered a hazard to road users under *The safe system approach*⁽¹⁴⁾. Therefore there may be a requirement to install a traffic safety barrier system at piers, abutments or retaining walls regardless of whether they have been designed for collision loading or not.

Collision loads, applied as equivalent static loads, need only be considered at the ultimate limit state. Load factors to be considered at the moment of the collision shall be for load combination 3C given in table 3.2 unless specified otherwise. Load factors and combinations for any loads considered after collision are detailed in the following.

b. Collision load from road traffic

i. Collision with bridge substructure

Bridges over a highway shall be designed to resist a collision load of 2000kN applied to the piers or abutments supporting the bridge (including reinforced soil abutment walls), unless the piers or abutments concerned are located behind traffic barriers meeting performance level 5 or higher, as set out in appendix B, in which case they shall be designed to resist a collision load of 250kN. Each of these collision loads shall be applied horizontally 1.2m above ground level at an angle of 10 degrees from the direction of the centreline of the road passing under the bridge.

Where a pier or abutment consists of individual columns these shall each be designed to resist the collision load as detailed above. For a pier or abutment that consists of a wall, it shall be designed to resist the component of the collision load that is perpendicular to the face of the wall including the end face(s) of the wall facing oncoming traffic. At a corner both components of the load shall be applied simultaneously. If there is any projection from a wall greater than 100mm that could snag a vehicle sliding along the wall face then the wall shall also be designed to resist the component of the collision load that is parallel to the wall, applied at the projection. In such instances the collision load applied to calculate the component shall vary linearly from 333kN at 100mm projection width to 2000kN at 600mm or greater projection.

3.4.18 continued

The substructure, including 'redundant' piers or columns, may alternatively be designed for a reduced collision load of 250kN applied at any angle in the horizontal plane at 1.2m above ground level subject to the agreement of the road controlling authority, if:

- o it can be demonstrated that the piers or abutments concerned are located such that collisions are highly improbable (eg where abutments are protected from collision by earth embankments or by considering the annual frequency for a bridge pier to be hit by a heavy vehicle (AFHBP) in accordance with clause 3.6.5.1 of AASHTO LRFD *Bridge design specifications*⁽¹⁵⁾); or
- o a bridge has sufficient redundancy to prevent collapse under permanent loading plus live load using load factors for load combination 1A at the serviceability limit state given in table 3.1, with one pier or column removed (either one column to multi-column piers or the whole pier to single column piers). The effects of this load combination shall be assessed using ultimate limit state analysis; or
- o an abutment can be shown to have sufficient redundancy so that the bridge will not collapse in the event of a collision.

Where it is proposed that the full collision load with a bridge substructure is not to be designed for, where collisions are considered highly improbable or redundancy in the bridge structure is being relied on, the justification shall be included in the structure options report and structure design statement as details are developed.

ii. Collision with bridge superstructure

For bridges where the vertical clearance to the bridge superstructure is 6.0m or less from an underlying road carriageway, collision loads of 750kN acting normal to the bridge longitudinal direction and 375kN acting parallel to the bridge longitudinal direction (both loads acting in any direction between horizontal and vertically upward) shall be considered to act at the level of the soffit of the outside girders, or at the level of the outer soffit corners of a box girder or slab superstructure. The load normal to the carriageway shall be considered separately from the load parallel to the carriageway. Also where the vertical clearance to the bridge superstructure is 6.0m or less, all inner girders shall be designed for a soffit collision load of 75kN acting normal to the bridge longitudinal direction (and in any direction between horizontal and vertically upward).

For bridges where the vertical clearance to the bridge superstructure exceeds 6.0m (noting the requirements of figure A4 to make provision for settlement and road surfacing overlays in maintaining design vertical clearances) from an underlying road carriageway a collision load of 75kN acting normal to the bridge longitudinal direction shall be considered to act as a single point load on the bridge superstructure at any location along the bridge and in any direction between the horizontal and vertically upwards. The load shall be applied at the level of the soffit of the outside girders, or at the level of the outer soffit corners of a box girder or slab superstructure.

Collision loads shall be treated as point loads, or may be distributed over a length of not more than 300mm of the impacted member. No other live load need be considered to coexist.

For concrete bridge superstructures, steel nosings shall be incorporated, above the approach traffic lanes, in the leading edge soffit of each beam where the vertical clearance to the bridge superstructure is 6.0m or less, and to the leading edge soffit of the leading beam only where the vertical clearance to the bridge superstructure is greater than 6.0m and less than 10m.

3.4.18 continued

The steel nosing for leading beams shall comprise composite 20mm thick plates extending vertically 200mm above the soffit and horizontally 200mm across the soffit. For other beams the steel nosing shall comprise composite 10mm thick plates extending vertically 150mm above the soffit and horizontally 150mm across the soffit. The plates shall be galvanized, and if exposed to view, shall have a cover coat to blend with the adjacent surfaces. Consideration shall be given to the effects that any steel nosing has on beam flexural behaviour.

iii. Collision with retaining walls

Retaining walls shall be designed to resist collision loading where:

- o they are associated with bridges
- o they are not associated with bridges and vehicle collision could result in:
 - part or all of the wall, including components such as precast concrete cladding panels, collapsing onto the traffic lanes of the carriageway
 - failure of part or all of the wall, endangering adjacent property.

Collision loading shall consist of a load of 2000kN applied horizontally 1.2m above ground level at an angle of 10 degrees from the direction of the centreline of the road passing near the wall. Any face of the wall shall be designed to resist the component of the collision load that is perpendicular to the face. At a corner both components of the load shall be applied simultaneously. Collision loading on any projection from a wall shall be considered as for abutment walls in 3.4.18(b)(i).

A reduced load applied in a similar manner at a greater height up a retaining wall, varying in magnitude from 2000kN at 1.2m above ground level to 500kN at 5.0m, shall also be considered separately.

These collision loading requirements shall not apply to:

- o retaining walls associated with bridges that are located behind traffic barriers meeting performance level 5 or higher, as set out in appendix B
- o retaining walls not associated with bridges that are located behind traffic barriers meeting performance level 4 or higher, as set out in appendix B
- o retaining walls located such that collisions are highly improbable.

iv. Collision with the above deck level structure of through truss, tied arch and other similar bridge structures, protection beams and retaining wall props

Through truss, tied arch and other similar bridge structures with above deck level structure providing the primary structural support to spans shall be designed for collision from a vehicle traversing the bridge. The design collision loads specified herein shall also apply to the design of protection beams installed to protect the superstructure of low clearance bridges from collision from road vehicles and for collisions with props to retaining walls where the roadway is depressed below ground level in a trench.

Bridge structural elements projecting above deck level at either side of the bridge carriageway shall be protected from collision by rigid traffic barriers meeting performance level 5 or higher. Clearance between the barrier and structure shall be as required in 3.4.18(b)(vii).

3.4.18 continued

Bridge structural elements and other major elements projecting above the top of the side protection barriers or overhead of the road carriageway shall be designed for the collision loads given below. The load acting in the vertical plane normal to the bridge carriageway alignment shall be considered separately from the load acting in the vertical plane parallel to the bridge carriageway alignment. The loads shall be considered to act as point loads on the bridge elements in any direction between horizontal and vertically upwards. The load shall be applied to the element's leading corner nearest the carriageway considered in the direction of the vehicle travel.

The design collision loads shall be as follows, modified as specified below for the various structural elements:

- o Load acting in the vertical plane perpendicular to the bridge carriageway's longitudinal alignment: 375kN.
- o Load acting in the vertical plane parallel to the bridge carriageway's longitudinal alignment: 750kN.

Arch ribs, truss end posts and similar structural elements shall be designed for the full specified collision loading above, striking at all possible levels between the top of barrier level and 10m above road carriageway level.

The leading overhead structural member at each end of the bridge and within 10m of the carriageway shall be designed for the full collision loading specified.

Truss web members, arch rigid hanger members (as distinct from cable or single bar hangers) and overhead structural members within 10m of the carriageway, beyond 20m from the leading members, moving along the bridge in the direction of travel, shall be designed for one-third of the design collision load.

Truss web members, arch rigid hanger members (as distinct from cable or single bar hangers) and overhead structural members within 10m of the carriageway, within 20m from the leading members, moving along the bridge in the direction of travel, shall be designed for collision loading linearly interpolated with distance from the leading member to 20m from the leading member.

Collision loads shall be treated as point loads, or may be distributed over a length of not more than 300mm of the impacted member. No other live load other than the colliding vehicle, which shall be taken as the HN vehicle without lane load, need be considered to coexist at the moment of the collision. This vehicle load may be considered as an overload (OL) for the determination of load factors.

Single bar and cable hangers of tied and network arch structures shall satisfy the requirements of 4.9.

v. Non-concurrency of loading

Vehicle collision load on the supports and on the superstructure shall be considered to act non-concurrently.

vi. Exemptions

An exception to the above requirements will be considered where providing such protection would be impractical or the costs would be excessive, providing that the structure has sufficient redundancy to prevent collapse as a result of a collision. Such cases require justification in the structure options report and structure design statement as details are developed, and any variations to the requirements of this manual are subject to the agreement of the road controlling authority.

3.4.18 continued

vii. Collision protection

Where barriers are placed adjacent to a structure, or provide protection to a structure from vehicle collision, a minimum separation, to provide clearance to accommodate any barrier deflection and the colliding vehicle's tendency to roll over the barrier, shall be provided between the barrier front face and the face of the structure as follows:

- o Flexible or semi-rigid barriers: the working width of the barrier system, defined as the sum of the dynamic deflection of the barrier and the vehicle roll allowance (or the barrier system width if it is larger than the vehicle roll allowance). Refer to Austroads *Guide to road design* part 6 Roadside design, safety and barriers⁽¹⁶⁾ clauses 6.3.15 to 6.3.17.
- o Performance levels 4 and 5 F type rigid barrier: vehicle roll allowance of 1.1m from the barrier front face. The dynamic deflection for a rigid barrier is zero.
- o Where rigid barriers are orientated normal to crossfall of the road sloping towards the structure, the separation shall be increased by $4.25\text{m} \times \frac{\text{crossfall percentage}}{100}$.

c. Collision load from railway traffic

i. Collision with bridge substructure

Where possible, rail crossings should be a clear span between abutments.

Where bridge supports (ie abutment walls, piers or columns) are located within 20m of a rail track centreline the bridge shall be designed in accordance with one of the following:

- o Unless agreed otherwise by the road controlling authority and the railway authority, the bridge shall have sufficient redundancy to prevent collapse under permanent loading plus live load using load factors for load combination 1A at the serviceability limit state given in table 3.1, should part of an abutment wall or one or more pier or column be removed or rendered ineffective as a result of a collision. The number and location of supporting structures to be considered as removed by a train collision shall be determined by a risk analysis, and shall be subject to the agreement of the road controlling authority and the railway authority. The effects of this load combination shall be assessed using ultimate limit state analysis.

For bridges over KiwiRail tracks, these provisions for design for redundancy to prevent collapse shall apply where bridge supports are situated within 5m of a rail track centreline (see *KiwiRail Railway bridge design brief*⁽¹⁷⁾).

A 'redundant' bridge support shall be designed to resist a collision load of 250kN applied at any angle in the horizontal plane at 2m above rail level unless otherwise directed by the authorities noted above.

- o Alternatively, and with the agreement of the road controlling authority and the railway authority, the bridge supports shall be designed to resist collision loads.

Where bridge supports are situated within 10m of a rail track centreline, they shall be designed to resist the following collision loads applied simultaneously:

- 3000kN parallel to the rails
- 1500kN normal to the rails

Both loads shall be applied horizontally, at 2m above rail level.

3.4.18 continued

Where bridge supports are situated between 10m and 20m from a rail track centreline they shall be designed to resist a collision load of 1500kN applied at any angle in the horizontal plane at 2m above rail level. This provision may be relaxed through a risk analysis subject to the agreement of the road controlling authority and the railway authority.

ii. Collision protection to bridge substructure

Bridge substructures shall be protected from collision in accordance with the requirements of the railway authority.

Bridges over KiwiRail tracks where bridge supports are situated within 5m of a rail track centreline shall be provided with collision protection consisting of an impact wall, designed in accordance with the KiwiRail *Railway bridge design brief*⁽¹⁷⁾. The impact wall shall be standalone if the bridge is being designed for the redundancy requirements of 3.4.18(c)(i) or otherwise may be standalone or monolithic with the bridge supports being protected. The impact wall shall extend in length for not less than 2.0m to either side of the bridge support.

Bridges over KiwiRail tracks where bridge supports are situated greater than or equal to 5m and within 10m of a rail track centreline shall be protected by a robust kerb, the purpose of which is to reduce the momentum of a derailed train (see KiwiRail *Railway bridge design brief*⁽¹⁷⁾).

iii. Collision protection to bridge superstructure

Bridge superstructures where the vertical clearance is 5.5m or less from an underlying railway (noting any requirements of the railway authority to make provision for settlement or lifting of tracks in design vertical clearances) shall be designed for a 500kN collision load. The collision load shall be applied in any direction directed towards the bridge superstructure from the adjacent track centre-line, except downwards. Where the vertical clearance is more than 5.5m vertically above the railway track level, the bridge superstructure shall be designed for a 75kN collision load applied from the track centre-line in any direction except downwards.

The collision load shall not be applied in conjunction with the loads specified in 3.4.18(c)(i).

In addition and in all instances, any further requirements of the railway authority shall be satisfied.

The details of all provisions made for and agreements made with the railway authority shall be included in the structure design statement.

d. Collision load from shipping

Possible collision loads from shipping shall be considered. Bridge piers shall either be protected by auxiliary structures designed to absorb the collision energy, or they shall be designed to resist collision from vessels operating under both normal conditions and extreme events that could occur during the life of the bridge. Design loads shall be assessed and included in the structure design statement.

3.5 Combination of load effects

The effects of the loads described in 3.2 to 3.4 shall be combined by summing each load effect multiplied by the relevant load factors shown in tables 3.1 and 3.2, and as specified below:

- a. In any combination, if a worse effect is obtained by omitting one or more of the transient items, this case shall be considered. Similarly the case of any 'permanent' load that is not always present (eg superimposed dead load, shrinkage and creep or settlement that are not initially present) shall be considered if a worse effect is obtained in addition to the reduced load effect noted in table 3.2.
 - b. The required wind and seismic resistance of structures during construction is difficult to specify in a general manner. Variables such as duration of construction stage, vulnerability of the structure and surroundings at each stage, and cost to temporarily improve the wind and seismic resistance shall all be taken into account. The load components of combinations 5A and 5C shall give adequate protection in the circumstances being considered.
 - c. The load combinations specified cover general conditions. Provision shall also be made for other loads where these might be critical.
 - d. For the consideration of stability, maintenance of structural integrity and the design of bridge deck joints for seismic response, these aspects of design are not captured by tables 3.1 and 3.2 and reference shall be made to 5.1.3 and 5.7.1(b). The design of elastomeric bearings for load combination 3A of table 3.1 shall comply with 4.7.2 for the level of earthquake loading and displacements specified therein. The design for load combinations that include earthquake loading shall take into account the additional requirements specified in section 5 for seismic design that are not applicable to design for non-seismic load combinations.
-

Table 3.1: Load combinations and load factors for the serviceability limit state

Load symbol	Combination		Permanent																						
	1A	1B	Structure			Soil			Water	Construction															
			DL	EL	SG	PS	EP	GW	ST	OW	CN	LLxI	OLxI	FP	HE	CF	CO	Water		Other					
																			FW	PW	EQ	WD	SN	TP	
Primary normal traffic cases			1.00	1.00	1.00	1.00	1.00	1.00	1.00	1.00	-	1.35	-	1.00	-	1.00	-	-	-	-	-	-	-	-	-
			1.00	1.00	1.00	1.00	1.00	1.00	1.00	1.00	-	-	-	1.00	-	1.00	-	-	-	-	-	-	-	1.00	1.00
			1.00	1.00	1.00	1.00	1.00	1.00	1.00	1.00	-	-	1.35	-	1.00	1.00	1.00	-	-	-	-	-	-	-	-
Secondary normal traffic cases			1.00	1.00	1.00	1.00	1.00	1.00	1.00	1.00	-	1.35	-	1.00	-	1.00	-	-	-	-	-	-	-	-	-
			1.00	1.00	1.00	1.00	1.00	1.00	1.00	1.00	-	-	-	1.00	-	1.00	-	-	-	-	-	-	-	-	-
			1.00	1.00	1.00	1.00	1.00	1.00	1.00	1.00	-	1.35	-	1.00	1.00	1.00	-	-	-	-	-	-	-	-	-
Primary lateral load cases			1.00	1.00	1.00	1.00	1.00	1.00	1.00	1.00	-	-	-	-	-	-	-	-	-	-	1.00	-	-	-	0.33
			1.00	1.00	1.00	1.00	1.00	1.00	1.00	1.00	-	-	-	-	-	-	-	-	-	-	1.00	1.00	-	-	-
			1.00	1.00	1.00	1.00	1.00	1.00	1.00	1.00	-	-	-	-	-	-	-	-	-	-	1.00	-	-	-	-
Traffic overload case			1.00	1.00	1.00	1.00	1.00	1.00	1.00	1.00	-	-	-	1.00	-	-	-	-	-	-	-	-	-	-	0.33
			1.00	1.00	1.00	1.00	1.00	1.00	1.00	1.00	-	-	-	-	-	-	-	-	-	-	-	-	-	-	0.33
Construction cases			1.00	1.00	1.00	1.00	1.00	1.00	1.00	1.00	-	-	-	-	-	-	-	-	-	-	-	-	-	-	1.00
			1.00	1.00	1.00	1.00	1.00	1.00	1.00	1.00	-	-	-	-	-	-	-	-	-	-	-	-	-	-	1.00

Notes: Where the effect of a possible reduction in permanent load is critical, replacement of the 'permanent load' by '0.9 x permanent load' shall be considered.

† Ordinary water pressure and buoyancy to be taken as due to the flow with an ARI of 1 year other than for load combination 3A (seismic) where it shall be taken as due to mean daily flow conditions.

Table 3.2: Load combinations and load factors for the ultimate limit state*

Load symbol	Combination		Permanent										Traffic				Environmental						
	DL	EL	SG	PS	EP	GW	ST	OW	CN	LLxI	OLxI	FP	HE	CF	CO	FW	PW	TS	EQ	WD	SN	TP	
Primary normal traffic cases	1A	1.35 (1.00)	1.35 (1.00)	1.00	1.82 (1.35)	1.00	1.35 (1.00)	1.35 (1.00)	-	2.25	-	1.76	-	2.25	-	-	-	-	-	-	-	-	-
	1B	1.35 (1.00)	1.35 (1.00)	1.35 (1.00)	1.82 (1.35)	1.00 (1.00)	1.35 (1.00)	1.35 (1.00)	-	-	-	-	-	-	-	-	-	-	-	-	-	-	1.69
Secondary normal traffic cases	2A	1.20 (1.00)	1.20 (1.00)	1.00 (1.00)	1.20 (1.00)	1.00 (1.00)	1.20 (1.00)	1.20 (1.00)	-	1.20	-	1.20	1.20	1.20	-	-	-	-	-	-	-	-	1.20
	2B	1.35 (1.00)	1.35 (1.00)	1.35 (1.00)	1.35 (1.00)	1.00 (1.00)	1.35 (1.00)	1.35 (1.00)	-	1.35	-	1.35	1.35	1.35	-	-	-	-	-	-	1.00	-	-
	2C	1.35 (1.00)	1.35 (1.00)	1.35 (1.00)	1.35 (1.00)	1.00 (1.00)	1.35 (1.00)	1.35 (1.00)	-	1.35	-	1.35	1.35	1.35	-	-	1.00	-	-	-	-	-	-
Primary lateral load cases	3A	1.00	1.00	1.00	1.35	1.00	1.00	1.35 (1.00)	-	-	-	-	-	-	-	-	-	-	1.00	-	-	-	0.33
	3B	1.10 (1.00)	1.10 (1.00)	1.10 (1.00)	1.38 (1.25)	1.00 (1.00)	1.10 (1.00)	1.10 (1.00)	-	-	-	-	-	-	-	-	-	1.00	-	1.00	-	-	-
	3C	1.00	1.00	1.00	1.35	1.00	1.00	1.35 (1.00)	-	-	-	-	-	-	1.00	-	-	-	-	-	-	-	0.33
Traffic overload case	3D [§]	1.20 (1.00)	1.20 (1.00)	1.20 (1.00)	1.20 (1.00)	1.00 (1.00)	1.20 (1.00)	1.20 (1.00)	-	-	-	-	-	-	-	-	1.00	-	-	0.33	-	-	1.20
	3E	1.00	1.00	1.00	1.35	1.00	1.00	1.00	-	-	-	-	-	-	-	-	-	1.00	-	-	-	-	0.33
Construction cases	4	1.35 (1.00)	1.35 (1.00)	1.00 (1.00)	1.35 (1.00)	1.00 (1.00)	1.35 (1.00)	1.35 (1.00)	-	-	-	0.95	-	1.49	-	-	-	-	-	-	-	-	0.45
	5A	1.35 (1.00)	1.35 (1.00)	1.35 (1.00)	1.35 (1.00)	1.00 (1.00)	1.35 (1.00)	1.35 (1.00)	1.49	-	-	-	-	-	-	-	-	-	-	0.33	-	-	-
	5B	1.35 (1.00)	1.35 (1.00)	1.35 (1.00)	1.35 (1.00)	1.00 (1.00)	1.35 (1.00)	1.35 (1.00)	1.49	-	-	-	-	-	-	-	-	-	-	-	-	-	1.00
5C	1.35 (1.00)	1.35 (1.00)	1.35 (1.00)	1.35 (1.00)	1.00 (1.00)	1.35 (1.00)	1.35 (1.00)	1.49	-	-	-	-	-	-	-	-	-	-	-	-	-	-	0.33

Notes: Where the effect of a possible reduction in a permanent load is critical, use of the lower bracketed load factors shall be considered.

* Also load combinations and load factors for damage control limit state (DCLS) and collapse avoidance limit state (CALC) in accordance with sections 5 and 6.

† γ_{FL} shall be as defined in 3.4.8(a).

‡ Ordinary water pressure and buoyancy to be taken as due to the flow with an ARI of 1 year other than for load combination 3A (seismic) where it shall be taken as due to mean daily flow conditions.

§ Combination 3D applies only to the design of footbridges.

3.6 References

- (1) NZ Transport Agency (2013) *A new vehicle loading standard for road bridges in New Zealand*. Research report 539, Wellington.
- (2) NZ Transport Agency (2014) *Fatigue design criteria for road bridges in New Zealand*. Research report 547, Wellington.
- (3) Standards Australia AS 5100.6-2004 *Bridge design*. Part 6 Steel and composite construction. Superseded.
- (4) New Zealand Heavy Engineering Research Association (2007) *Recommended draft fatigue design criteria for bridges version 3*. Manukau City.
- (5) British Standards Institution BS 5400-2:1978 *Steel concrete and composite bridges*. Part 2 Specification for loads. Withdrawn.
- (6) Highways England (2001) BD 37/01 *Loads for highway bridges*. TSO, London, United Kingdom.
- (7) Highways England (2001) BD 49/01 *Design rules for aerodynamic effects on bridges*. TSO, London, United Kingdom.
- (8) Standards Australia and Standards New Zealand jointly AS/NZS 1170.2:2011 (R2016) *Structural design actions part 2 Wind actions*. (Incorporating Amendment No. 5: 2017)
- (9) Standards Australia AS 5100.2:2017 *Bridge design*. Part 2 Design loads.
- (10) Standards Australia AS 5100.1:2017 *Bridge design*. Part 1 Scope and general principles.
- (11) Standards Australia and Standards New Zealand jointly AS/NZS 1170.3:2003 *Structural design actions*. Part 3 Snow and ice actions. (Incorporating Amendment No. 2: 2017)
- (12) Csagoly PF, Campbell TI and Agarwal AC (1972), *Bridge vibration study*. Report no. RR 181, Ministry of Transport and Communications, Ontario, Canada.
- (13) British Standards Institution (2008) NA to BS EN 1991-2:2003 *UK National Annex to Eurocode 1. Actions on structures*. Part 2 Traffic loads on bridges
- (14) NZ Transport Agency *The safe system approach*. Last accessed 28 September 2018.
<www.saferjourneys.govt.nz/about-safer-journeys/the-safe-system-approach>.
- (15) American Association of State Highway and Transportation Officials (2014) *LRFD Bridge design specifications, customary U.S. units, 7th edition*. Washington DC, USA.
- (16) Austroads (2010) *Guide to road design*. Part 6 Roadside design, safety and barriers, AGRD06-10. Sydney, NSW, Australia.
- (17) KiwiRail (2010) *Structures code supplement – Railway bridge design brief*. W201, Issue 6. Wellington.

(This page is intentionally blank)

Superseded

4.0 Analysis and design criteria

In this section	Section	Page
	4.1 Analysis	4-2
	4.2 Reinforced concrete and prestressed concrete	4-2
	4.3 Structural steel and composite construction	4-12
	4.4 Timber	4-20
	4.5 Aluminium	4-21
	4.6 Other materials	4-21
	4.7 Bearings and deck joints	4-21
	4.8 Integral and semi-integral abutments	4-29
	4.9 Network and tied arch bridges - hanger supports	4-33
	4.10 Buried structures	4-35
	4.11 Bridges subject to inundation by flooding	4-40
	4.12 Miscellaneous design requirements	4-41
	4.13 References	4-47

4.1 Analysis

Structural components shall be designed for the most adverse effects arising from eccentricity of loading or curvature of the bridge. The analysis method used shall take account of the relative stiffness of longitudinal and transverse members, and the stiffness used for reinforced concrete members shall take account of the effects of flexural cracking.

4.2 Reinforced concrete and prestressed concrete

4.2.1 General

Design shall be in accordance with NZS 3101.1&2 *Concrete structures standard*⁽¹⁾, with the following provisos:

a. Crack widths (clause 2.4.4.2)

Crack widths under the application of load combination 1B as defined in table 3.1 shall not exceed the limits specified in table 4.1 unless alternatively the requirements of NZS 3101⁽¹⁾ clause 2.4.4.1(a) are satisfied.

Table 4.1: Crack width limits

	Exposure classification	Crack width limit
Reinforced concrete Prestressed concrete	A2, B1, B2	0.35mm 0.20mm
Reinforced concrete Prestressed concrete	C	0.25mm 0.10mm

Care should be exercised when designing deep beams using the strut and tie method as cracks can become large when this method is used.

Deck reinforcement design shall be exempt from a check of crack widths when the empirical design method specified by NZS 3101⁽¹⁾ section 12.8 is used.

b. Design for durability (section 3)

i. General

For designs based on the use of concrete made with GP, GB or HE cement complying with NZS 3122 *Specification for Portland and blended cements (General and special purpose)*⁽²⁾ with or without supplementary cementitious materials (SCM) complying with AS/NZS 3582 *Supplementary cementitious materials*⁽³⁾, durability of the reinforced or prestressed concrete shall be designed for in accordance with the requirements of NZS 3101⁽¹⁾ except as modified herein.

ii. Equivalent terminology

The term 'design working life' adopted in this manual shall be taken to equate to the term 'specified intended life' adopted by NZS 3101⁽¹⁾ clause 3.3.1.

4.2.1 continued

iii. Site exposure classification

All parts of bridges, major culverts, stock underpasses, pedestrian/cycle subways and retaining walls shall be considered to be in an 'exterior' type of environment.

In ascertaining the site exposure classification, where specific evaluation of a site is proposed in accordance with NZS 3101⁽¹⁾ clause 3.4.2.4, Coastal frontage zone extent, or clause 3.4.2.5, Tidal/splash/spray zone, this shall be treated as a special study as described by AS/NZS 1170.0 *Structural design actions* part 0 General principles⁽⁴⁾ and shall be fully documented in an appendix to the structure design statement.

In the case of the tidal/splash/spray zone, unless exposure classification C is adopted as the default, a special study is required to define the extent of the C zone in the vertical direction, which shall be taken to extend from the mean low water level at depth upwards to a height above sea level that is determined by prevailing wind and sea conditions.

The height of the upper boundary shall be defined by a decrease in the aggressiveness of the exposure environment such that the selected mix design for the B2 exposure classification can be demonstrated to achieve a 100-year life. To carry out this evaluation, a series of chloride profiles as a function of height above sea level will need to be determined on nearby concrete structures of similar exposure, to indicate the long-term surface chloride profile likely to be established in the concrete at the site under consideration. If nearby structures are not available, height profiles from closely comparable environments will need to be substituted.

The measured chloride concentrations are then to be employed as an input to a service life prediction model based on Fick's laws to verify the height at which the B2 mix design becomes adequately durable, which shall then be taken as the upper boundary position for the C zone. The application of the service life prediction model shall comply with NZS 3101⁽¹⁾ part 2 clause C3.12.1 with adequate durability being taken as a minimum time to first rusting of 80 years.

iv. Requirements for aggressive soil and groundwater exposure classification XA

Concrete in members subject to chemical attack shall be specified in accordance with table 4.2 which replaces table 3.4 in NZS 3101⁽¹⁾ for members with a design working life of 100 years. Such concrete shall be specified as 'special concrete' under NZS 3109 *Concrete construction*⁽⁵⁾ clause 6.3.

Table 4.2: Requirements for Concrete Subjected to Natural Aggressive Soil and Groundwater Attack

Chemical exposure classification	Maximum water cementitious ratio	Minimum cover (mm)	Minimum binder content (kg)	Additional requirement
XA1	0.50	65	340	---
XA2	0.45	65	370	SCM
XA3	0.40	75	400	SCM

Notes:

1. Binders containing combinations of cement and SCM (fly ash, slag or amorphous silica) provide significantly increased resistance to chemical attack mechanisms.
2. Where low pH and high exchangeable soil acid conditions prevail, an additional protection (eg protective coating or other form of physical protection) may be required. This may allow for reduction of originally specified concrete parameters.

4.2.1 continued

v. Minimum concrete curing requirements

NZS 3101⁽¹⁾ table 3.5 is clarified as follows: Note 3 of the table shall be taken as applying to the curing of concrete associated with exposure classifications C, XA2 and XA3 only, with alternative curing methods being alternatives to water curing.

The use of heat accelerated curing (eg as specified by the NSW Roads and Maritime Services QA specification B80 *Concrete work for bridges*⁽⁶⁾) as an alternative method to water curing in the C exposure zone shall be subject to a special study to demonstrate equivalent performance.

Another potentially acceptable alternative method to water curing in the C exposure zone is sealed curing used in conjunction with concrete cover increased above that specified by NZS 3101⁽¹⁾ table 3.7. This approach shall also be subject to verification by a special study to establish the increase in concrete cover required to provide equivalent performance.

vi. Additional requirement for concrete exposure classification B2

Concrete for use in the exposure classification zone B2 shall have a minimum specified 28 day compression strength of not less than 40MPa.

vii. Life prediction models and durability enhancement measures

There are a number of alternative durability enhancing measures which can be taken to extend the life of concrete structures and provide the required durability other than those specified by NZS 3101⁽¹⁾ chapter 3. These include concrete coatings, corrosion inhibiting admixtures, galvanized or stainless steel reinforcement, controlled permeability formwork, glass fibre reinforced concrete (GRC) permanent formwork, and cathodic protection. Life prediction models offer an alternative approach to use of NZS 3101⁽¹⁾ table 3.7 for determination of covers for the C and B2 zones. Adoption of any of these or other alternative measures shall be the subject of a special study as described in AS/NZS 1170.0⁽⁴⁾, and shall be fully documented in an appendix to the structure design statement. Where a life prediction model is proposed to be used, the structure design statement appendix shall include full details of the formulation and calibration of the model.

viii. Subways and culverts accessible by stock

A B2 exposure classification shall be adopted for the floor and bottom 1.2m of the height of walls of subways and box culverts accessible by stock due to possible exposure to stock effluent.

c. Friction losses (clause 19.3.4.2.3)

It should be noted that the apparent coefficient of friction for post-tensioned cables deflected at isolated points is likely to be significantly higher than that for equivalent cables curved over their whole length. This shall be taken into account in the design.

d. Reinforced concrete bridge deck slab thickness (table 2.3)

For a uniform concrete slab, monolithic with concrete webs, L_s shall be taken as the clear span.

For a haunched slab, monolithic with concrete webs, or tied down to steel girders, where thickness at root of haunch is at least 1.5 times thickness at centre of slab, L_s shall be taken as the distance between midpoints of opposite haunches.

For a uniform slab on steel girders, L_s shall be taken as the average of the distance between webs and the clear distance between flange edges.

4.2.1 continued

For deck slabs designed by the empirical method of NZS 3101⁽¹⁾ clause 12.8, the minimum slab thickness requirements of that clause shall take precedence over the requirements of NZS 3101⁽¹⁾ table 2.3.

e. Shrinkage and creep effects in concrete

Assessment of shrinkage and creep effects shall be undertaken in accordance with NZS 3101⁽¹⁾ (including amendment 3). Design shrinkage strain shall be determined as the sum of chemical (autogenous) and drying shrinkage as given in NZS 3101⁽¹⁾ appendix E. It is noted that autogenous shrinkage is essentially complete at about 50 days after initial setting of the concrete.

In the application of the NZS 3101⁽¹⁾ procedure for shrinkage and creep to structural concrete mixes based on Type GP cement with restricted water demands and moderate workability (slump 50 - 100mm), the relative humidity factor (k_A) may be derived from table 4.3, based on the average relative humidity for the locality. Table 4.4 presents average basic drying shrinkage strains ($\epsilon_{csd,b}$) for a range of New Zealand aggregates for use in NZS 3101⁽¹⁾ equation E-4 to determine ϵ_{csd} , the drying shrinkage strain. Alternatively, ϵ_{csd} may be taken as equal to the 56 day drying shrinkage test result determined by using the method specified in AS 1012.13 *Methods of testing concrete* part 13 Determination of the drying shrinkage of concrete for samples prepared in the field or in the laboratory⁽⁷⁾, corrected for autogenous shrinkage over the drying period by subtracting $25(0.06f'_c - 1.0)$ microstrain.

The average relative humidity for a locality may be assessed from data available from the NIWA CliFlo⁽⁸⁾ database through their website. Table 4.5 presents average and 9am relative humidities, derived as noted below the table, for various locations throughout New Zealand. Figure 4.1 presents 9am relative humidities which may be used to estimate the average relative humidity for locations for which data is not available in the CliFlo⁽⁸⁾ database.

Note that for particularly dry parts of the country (eg Central Otago) the average relative humidity may vary quite significantly from the 9am relative humidity values. Conservative (low) assessments of relative humidities should be adopted as the basis for design. Guidance on using the CliFlo⁽⁸⁾ database is provided in C4 in the *Bridge manual commentary*.

Consideration shall be given to the fact that ϵ_{cs} has a range of $\pm 30\%$. Note also that high slump (eg pump-type) concrete mixes may have significantly higher levels of shrinkage.

For shrinkage sensitive structures, it is recommended that concrete suppliers who may potentially supply concrete for the structure be consulted about the shrinkage properties of their concrete, and that use of a super-plasticiser or shrinkage reducing admixture be considered. Such admixtures can significantly reduce shrinkage, although their use requires a higher degree of control in the production and placing of the concrete. Caution needs to be exercised in adopting very low shrinkage strains associated with the use of super-plasticisers and shrinkage reducing admixtures as there is a lack of published data, and thus uncertainty, over the long term shrinkage performance of concretes associated with their use. (Note that shrinkage reducing admixtures, which are most commonly used and do not need the concrete to be confined to be effective, should not be confused with shrinkage compensating admixtures, which generally induce initial expansion in the concrete before subsequent shrinkage takes place.)

4.2.1 continued

In general, a higher water content results in greater shrinkage for concretes made from a particular combination of aggregates. This trend may be modified by the use of admixtures to reduce water content. Greater drying shrinkage may also occur with the following types of mix:

- specified strength over 50MPa
- cementitious binder content exceeding 380kg/m³
- water to cement ratio less than 0.40.

Designers need to consider the potential for higher shrinkage for these types of concrete. This applies in particular to the design of deck slabs where restraint is provided by the supporting girders. It applies also to use of the empirical design method for deck slabs.

In addition to potentially greater drying shrinkage, these concretes, and concretes containing supplementary cementitious material, may have greater autogenous shrinkage. They also tend not to bleed, and consequently can exhibit greater plastic shrinkage. Plastic shrinkage may be severe in the case of low water/cement concrete containing supplementary cementitious material. Therefore the use of such concrete in deck slabs is not recommended.

Plastic shrinkage cracking occurs before the bond between concrete and reinforcing steel has developed, therefore the steel is ineffective in controlling this type of cracking. For such concretes, evaporation retarders (eg aliphatic alcohols) or misting should be used to reduce evaporation from the concrete surface and thereby to reduce plastic shrinkage. Use of micro synthetic fibres in the concrete mix can also be beneficial.

For concrete structures constructed in stages, the design shall take account of the shrinkage and creep effects of the concrete using an appropriate time dependent analysis. The final profile of the structure shall take account of the deflections that occur due to these effects over the life of the structure. In bridge superstructures, the post-construction deflection associated with these effects shall be less than span/1000.

Where precast concrete beams are made continuous by interconnection with reinforced in situ concrete at the intermediate supports, design for the effects of residual creep and differential shrinkage shall comply with the principles and general requirements of AS 5100.5 *Bridge design part 5 Concrete*⁽⁹⁾ section 8.10.

Table 4.3: Relative humidity factor (k_4)

Relative humidity (%)	40	50	60	70	80	90
Relative humidity factor (k_4)	0.74	0.68	0.61	0.50	0.39	0.21

Figure 4.1: Map of New Zealand 9am relative humidities (RH%)

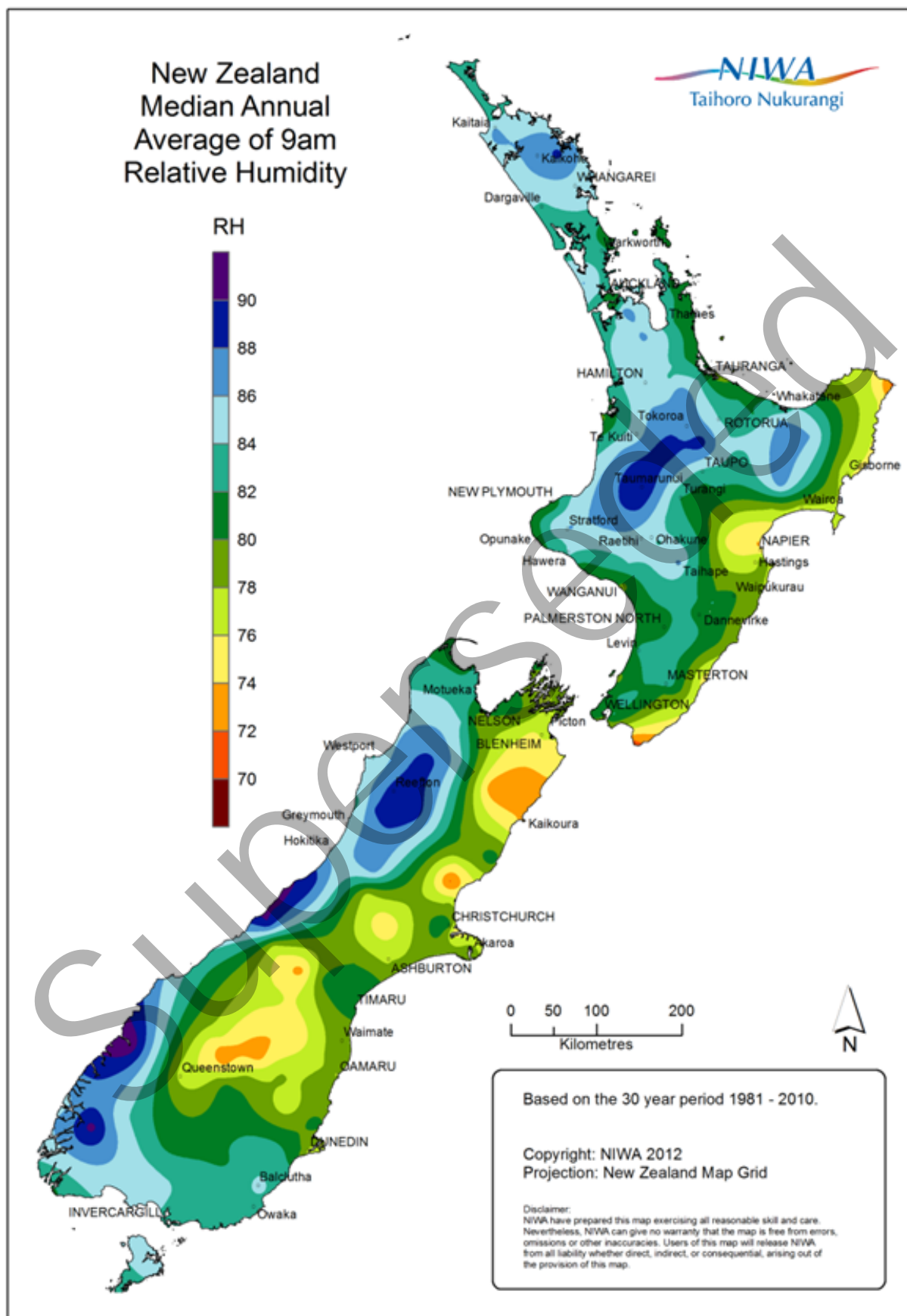

Figure 4.1 is reproduced with the permission of NIWA.

4.2.1 continued

Table 4.4: Basic drying shrinkage strain ($\epsilon_{csd,b}$)

Location	Aggregate type	Basic drying shrinkage (microstrain)
Whangarei, Auckland Hunua, Hamilton	Northern greywacke	720
Hastings, Palmerston North, Masterton, Wellington, Blenheim, Kaikoura	Central greywacke	1100
Christchurch, Timaru, Oamaru	Southern greywacke	700
Auckland	Basalt*	660
Kaitaia, Tauranga	Other andesite / basalt gabro	960
New Plymouth, Taranaki	Taranaki andesite	730
Waiau	Limestone	390
Nelson	Greywacke - siltstone	1100
Westport Queenstown, Wanaka Invercargill	Granite - greywacke Schist - greywacke Igneous - greywacke	590
Dunedin	Phonolite	520

Notes:

* Use of Auckland basalt aggregate is declining. In general for shrinkage design for the Auckland locality it is recommended that the value for Auckland greywacke be adopted instead.

Table 4.5: Average and 9am relative humidities for various locations

Location	RH (%)	Location	RH (%)	Location	RH (%)	Location	RH (%)
Kaikohe	85 (86)	Taupo	79 (84)	Wellington	76-81 (80)	Ashburton	77 (76)
Whangarei	80 (84)	Taumarunui	82 (88)	Nelson	77 (80)	Timaru	80 (80)
Dargaville	80 (84)	Gisborne	78 (76)	Blenheim	75 (76)	Franz Josef	84 (88)
Auckland	77-82 (82)	New Plymouth	83* (80)	Westport	83 (84)	Queenstown	70* (78)
Hamilton	82 (84)	Waiouru	82 (84)	Kaikoura	75 (74)	Alexandra	66* (80)
Tauranga	77 (80)	Napier	76 (74)	Greymouth	79 (84)	Oamaru	80 (78)
Whakatane	80 (82)	Whanganui	77 (80)	Hokitika	85* (84)	Dunedin	78 (78)
Rotorua	83* (84)	Palmerston North	80 (82)	Hanmer	76 (80)	Invercargill	81 (82)
Te Kuiti	77 (84)	Masterton	78 (82)	Christchurch	78 (76)		

Notes:

RH values not within brackets are average RH assessed from NIWA CliFlo⁽⁶⁾ data for the period 2008-12. RH values within brackets are 9am RH values assessed from figure 4.1.

* Conservative (low) estimates based on incomplete NIWA datasets. Data missing: Rotorua, New Plymouth, Hokitika - early hours of the morning; Queenstown - nighttime hours; Alexandra - nighttime hours and large and irregular gaps in daytime hours. In general, humidity is usually higher during the hours of darkness, peaking a little before dawn.

4.2.1 continued

f. Mechanical coupling and anchorage of reinforcing steel bars in concrete

i. General

Mechanical couplers for the jointing of reinforcing steel shall satisfy the requirements of NZS 3101⁽¹⁾ clauses 8.7.5 and 8.9.1.3, and ISO 15835-1 *Steels for the reinforcement of concrete - Reinforcement couplers for mechanical splices of bars* part 1 Requirements⁽¹⁰⁾ for category S2 couplers (seismic 2 - violent), except as modified herein. Mechanical anchors for the anchorage of reinforcing steel shall satisfy the requirements of NZS 3101⁽¹⁾ clauses 8.6.11 and 8.9.1.3, and ISO 15698-1 *Steel for the reinforcement of concrete - Headed bars* part 1 Requirements⁽¹¹⁾ for category S headed bars (seismic), except as modified herein. Where the requirements of these standards conflict, those contained in the NZS 3101⁽¹⁾ clauses referenced shall take precedence, unless specifically stated otherwise.

As per NZS 3101 clause 8.9.1.1(a) couplers shall not be located in or immediately adjacent to ductile and limited ductile plastic regions.

Couplers and anchors shall be legibly marked with identification as specified by NZS 3101⁽¹⁾ clause 8.7.5.5 and their method of installation shall be specified as required by NZS 3101⁽¹⁾ clause 8.7.5.6.

Where considered to be necessary, couplers shall also meet the requirements of the requirements of NZS 3101⁽¹⁾ for high cycle fatigue and those of ISO 15835-1⁽¹⁰⁾ for category F (fatigue); and anchors shall also meet the requirements of NZS 3101⁽¹⁾ for high cycle fatigue and those of ISO 15698-1⁽¹¹⁾ for category F2 (fatigue). The required cycles and stress range for both couplers and anchors shall be as for category F couplers in ISO 15835-1⁽¹⁰⁾.

Couplers and anchors manufactured from cast iron shall not be used.

Where, in the modification or strengthening of an existing structure, coupling to embedded reinforcement of unknown maximum ultimate tensile strength is proposed, the reinforcement shall either be tested to establish its ultimate tensile strength or a conservative over estimation made of its ultimate tensile strength as the basis for selection and design of the couplers in order to ensure that the performance requirements specified above are satisfied.

ii. Demonstration of conformity

Demonstration of conformity for both couplers and anchors shall be by one of the two methods allowed by ISO 15835-1⁽¹⁰⁾, ie system certification or batch verification. System certification shall be by a certification body accredited by JAS-ANZ (Joint Accreditation System of Australia and New Zealand) or accredited by other international accreditation schemes with the agreement of the road controlling authority. System certification shall be location of manufacture specific, ie any certificate shall be applicable to couplers or anchors manufactured at a specific location only and associated reinforcing steel bars manufactured at a specific location only.

Testing associated with system certification may be carried out in New Zealand rather than at location of manufacture. Testing associated with system certification and for batch verification shall be by an IANZ (International Accreditation New Zealand) accredited laboratory or equivalent agreed with the road controlling authority.

4.2.1 continued

Test methods for couplers shall be those specified in ISO 15835-2 *Steels for the reinforcement of concrete - Reinforcement couplers for mechanical splices of bars* part 2 Test methods⁽¹²⁾ for the categories of coupler detailed in (i). Test methods for anchors shall be those specified in ISO 15698-2 *Steel for the reinforcement of concrete - Headed bars* part 2 Test methods⁽¹³⁾ for the categories of anchor detailed in (i).

System certificates or batch certificates shall be provided for all couplers and anchors and associated reinforcing steel bars delivered to site.

iii. Brittle fracture resistance

In accordance with NZS 3101⁽¹⁾ clauses 8.6.11.4 and 8.7.5.2(a) respectively, mechanical anchors and couplers for the anchorage or jointing of reinforcing steel shall be proven by an appropriate test acceptable to the road controlling authority to possess resistance to brittle fracture down to a temperature of 0°C. Reinforcing steel bars shall also meet the brittle fracture requirements of AS/NZS 4671 *Steel reinforcing materials*⁽¹⁴⁾.

Presently test methods to indicate resistance to brittle fracture are limited in availability or are in development. Therefore where couplers, anchors or bar stock equivalent to the finished material of machined couplers or anchors are of sufficient size to enable Charpy V notch test specimens to be cut from them, Charpy V notch testing may be used to demonstrate brittle fracture resistance. Where this test method is applied, a Charpy V-notch impact resistance equal to or greater than 27 joules shall be achieved when standard 10mm x 10mm test pieces are tested at 0°C in accordance with AS 1544.2 *Methods for impact tests on metals* part 2 Charpy V-notch⁽¹⁵⁾ and assessed for acceptance as specified by AS/NZS 3678 *Structural steel - Hot-rolled plates, floorplates and slabs*⁽¹⁶⁾ table 9. Test pieces of smaller cross section as listed in AS/NZS 3678⁽¹⁶⁾ table 9 may be used when standard 10mm x 10mm cross-section test pieces are impractical. For these test pieces of smaller cross-section the acceptance criteria shall correspond to the LO impact designation and test piece cross-section given in AS/NZS 3678⁽¹⁶⁾ table 9.

For reinforcing steel bars, any testing undertaken shall be completed using bars that achieve a yield strength in excess of 330MPa for Grade 300E and 530MPa for Grade 500E.

g. Prestressed concrete

i. Design for shear

In the design of prestressed concrete members for shear, the concrete contribution to shear strength shall be computed in accordance with AASHTO *LRFD Bridge design specifications*⁽¹⁷⁾, clause 5.8.3.4.3, noting that the AASHTO equations are based on imperial units. (In respect to NZS 3101⁽¹⁾ clause 19.3.11.2.2 equation 19-15, the NZS 3101:1995⁽¹⁸⁾ Commentary noted that for beams subjected to point loads the equation should not be used, and also that the equation is not necessarily appropriate to continuous prestressed concrete members, such as a bridge superstructure, and that it may be non-conservative for thin webbed sections, common in bridge superstructures. This equation should therefore not be used.)

ii. Confining reinforcement and strand corrosion protection in pretensioned members

Adequate confining reinforcement shall be provided in the end zones of pretensioned prestressed concrete members to prevent splitting of the members.

4.2.1 continued

The ends of prestressing strand in pretensioned members shall be protected from corrosion in such a manner that no maintenance of the corrosion protection is required within the design life of the element.

iii. External post-tensioning

External post-tensioning shall not be used in locations accessible to the public or where there is a significant risk of fire in proximity to the tendons.

iv. Detailing of prestressed members

Grout for and grouting of post-tensioning ducts shall comply with the Concrete Institute of Australia's publication CIA Z3 *Grouting of prestressing ducts*⁽¹⁹⁾ for type A tendons. This shall include the provision of grout inlets, vents, caps and control valves or other approved methods of maintaining pressure and controlling flow.

In C and B2 exposure classifications as defined in NZS 3101⁽¹⁾, plastic post-tensioning duct with 2.0mm minimum wall thickness and coupled at all construction joints shall be used. The duct and accessories shall comply with *fib Bulletin 7 Corrugated plastic ducts for internal bonded post-tensioning*⁽²⁰⁾. In other exposure classifications corrugated galvanized steel ducts may be used. They shall be spirally wound from galvanized strip steel with a minimum wall thickness of 0.3mm and a coating weight in excess of 90 grams/m², and shall have welded or interlocking seams with sufficient rigidity to maintain the correct profile during concrete placement.

All anchorages shall have grout caps and seals for grouting operations as required by CIA Z3⁽¹⁹⁾. For C and B2 exposure classifications, anchorages shall have permanent grout caps made from fibre reinforced polymer or HDPE, bolted to the anchorage and sealed with O rings or gaskets against the bearing plate.

Further guidance on design details for post-tensioning may be found in:

- FHWA *Post-tensioning tendon installation and grouting manual*⁽²¹⁾
- UK Concrete Society technical report 72 *Durable post-tensioned concrete structures*⁽²²⁾.

h. Precast prestressed hollow core unit decks

Precast prestressed hollow core deck units shall be provided with sufficient transverse stressing to provide shear transfer without relative movement, and without cracks opening (ie with zero tension) on the longitudinal joints between units at the deck top surface under all serviceability load combinations. Transverse tendons shall be provided with at least a double corrosion protection system.

A double corrosion protection system will generally comprise a continuous, full length, watertight, electrically non-conductive, corrosion resistant, durable duct with the void between the duct and the tendon fully infilled with a corrosion inhibiting grout (eg cement grout).

i. Reinforcing steel

All reinforcing steel shall comply with the requirements of NZS 3109⁽⁵⁾ except that welded wire mesh may be of grade 500E steel and in which case shall comply with AS/NZS 4671⁽¹⁴⁾.

j. Design for fatigue

In the application of NZS 3101⁽¹⁾ clause 2.5.2.2, the stress range due to repetitive loading to be considered in flexural reinforcing bars shall be that due to live loading corresponding to table 3.1 load combination 1A, but without pedestrian (FP) loading.

4.2.1 continued

In the application of NZS 3101⁽¹⁾ clause 19.3.3.6.2, the stress range due to frequently repetitive live loading shall be that due to live loading corresponding to table 3.1 load combination 1A, but without pedestrian (FP) loading. The stress range due to infrequent live loading shall be taken to be that due to live loading, overload, wind loading and temperature effects corresponding to all other load combinations of table 3.1, including load combination 1A with pedestrian loading.

k. Bridge Piers

Regardless of shape or aspect ratio, bridge piers shall comply with the requirements of NZS 3101⁽¹⁾ section 10. Where bridge piers may be classified as walls, any additional requirements of NZS 3101⁽¹⁾ section 11 pertaining to walls shall also be satisfied. Where inconsistencies may exist between the requirements of section 10 and section 11, the requirements of section 10 shall take precedence unless otherwise justified and accepted by the road controlling authority.

Bridge piers shall also be designed for serviceability in accordance with NZS 3101⁽¹⁾ section 2.4 and, where applicable, section 19.

4.3 Structural steel and composite construction

4.3.1 General

Design for the steel componentry of bridge substructures, and any seismic load resisting componentry expected to behave inelastically, shall comply with NZS 3404:1997 *Steel structures standard*⁽²³⁾. Design for the steel componentry of bridge superstructures, including seismic load resisting components expected to behave elastically, shall be in accordance with AS/NZS 5100.6 *Bridge design* part 6 Steel and composite construction⁽²⁴⁾. This applies also to the design of steel componentry of major culverts, stock underpasses and pedestrian/cycle subways.

In addition to the brittle fracture requirements for plates and rolled sections of NZS 3404:1997⁽²³⁾ and AS/NZS 5100.6⁽²⁴⁾, consideration shall also be given to the brittle fracture of steel elements complying with standards other than those listed by NZS 3404:1997⁽²³⁾ section 2 and AS/NZS 5100.6⁽²⁴⁾ section 14 (eg fixings, high strength bars).

The design and construction of concrete deck slabs for composite bridges for all actions on the concrete deck shall be in accordance with NZS 3101⁽¹⁾, except that the design of shear connection between the concrete deck slab and steel girders and the design for longitudinal shear occurring within the deck slab and paps shall comply with AS/NZS 5100.6⁽²⁴⁾. The requirements of AS/NZS 5100.6⁽²⁴⁾ clause 6.2.3, as they relate to the design of the concrete deck slab for the control of cracking due to thermal and shrinkage effects, where they require a greater quantity of reinforcement than required by NZS 3101⁽¹⁾, shall also be complied with.

The design of substructure composite steel and concrete columns may be designed for composite action in compliance with AS/NZS 5100.6⁽²⁴⁾ but over the length of any potential plastic region the plate thickness of external steel sections encompassing a concrete core shall comply with NZS 3101⁽¹⁾ clause 10.3.11.6.1 and the detailing of concrete reinforcement in respect to confinement and splicing shall comply with NZS 3101⁽¹⁾.

4.3.1 continued

Steelwork fabrication and erection shall comply with AS/NZS 5131 *Structural steelwork - Fabrication and erection*⁽²⁵⁾, and where not specified by AS/NZS 5131⁽²⁵⁾, with any additional requirements of the withdrawn NZS 3404.1:2009 *Steel structures standard* part 1 Materials, fabrication, and construction⁽²⁶⁾. Steel material for the fabrication of structural components shall comply with the requirements of a standard listed in AS/NZS 5100.6⁽²⁴⁾ clause 2.2.1 or appendix H, or NZS 3404.1:2009⁽²⁶⁾ clause 2.2.1, and fasteners shall comply with AS/NZS 5100.6⁽²⁴⁾ clause 2.4 or NZS 3404.1:2009⁽²⁶⁾ section 2.3.

The NZTA research report RR 525 *Steel-concrete composite bridge design guide*⁽²⁷⁾ provides guidance on the design of steel girder bridge superstructures to the 2004 edition of AS 5100.6⁽²⁸⁾.

4.3.2 Application of NZS 3404:1997⁽²³⁾

a. Design loadings (clause 3.2.3)

The design load combinations for the ultimate limit state (ULS) and serviceability limit state (SLS) shall be those specified in this manual.

b. Seismic design structural performance factor (clause 12.2.2.1)

The structural performance factor (S_p) shall be as specified in this manual.

c. Damping values and changes to basic design seismic load (clause 12.2.9)

Within this clause, the wording 'loadings standard' shall be replaced by 'the NZ Transport Agency's *Bridge manual*'.

d. Methods of analysis of seismic-resisting systems (clause 12.3.2)

Within this clause, the wording 'loading standard' shall be replaced by 'the NZ Transport Agency's *Bridge manual*'.

4.3.3 Application of AS/NZS 5100.6⁽²⁴⁾

a. Application (clause 1.3)

Within clause 1.3 replace the second paragraph with: "In the design of steel concrete composite members, the general requirements of NZS 3101 pertaining to the design of concrete shall apply, where relevant, in addition to the requirements of AS/NZS 5100.6."

b. General - Aim (clause 3.1.1) and Design for the ultimate limit state (clause 3.1.2)

Within section 3.1, reference to AS 5100.1 *Bridge design* part 1 Scope and general principles⁽²⁹⁾ shall be replaced by New Zealand Transport Agency *Bridge manual*.

c. Design for the ultimate limit state (clauses 3.1.2 and 3.2)

The design of superstructure componentry remaining elastic when subjected to damage control limit state (DCLS) seismic loading shall be designed on the basis of the capacity design principles specified in section 5 of this manual (ie for the actions induced in them by yielding elements mobilising their overstrength capacity under seismic response), where these actions exceed those of other ultimate limit state load combinations.

d. Design for serviceability - Vibration of beams (clause 3.3.3) and Steel reinforcement (clause 3.3.5)

Within clause 3.3.3, reference to AS 5100.2 *Bridge design* part 2 Design loads⁽³⁰⁾ shall be replaced by New Zealand Transport Agency *Bridge manual*.

Within clause 3.3.5, reference to AS 5100.5 *Bridge design* part 5 Concrete⁽⁹⁾ shall be replaced by New Zealand Transport Agency *Bridge manual*, clause 4.3.1.

4.3.3 continued

e. Shear buckling capacity (clause 5.10.5.2)

At the end of clause 5.10.5.2, amend the reference to appendix A in the note to appendix B.

f. Composite beams and composite compression members – references to AS 5100.5⁽⁹⁾ (sub-section 6.2, clause 6.8.5, and sub-sections 10.6, 10.7, 10.8)

Within clauses 6.2.1, 6.2.3, and 6.8.5, reference to AS 5100.5⁽⁹⁾ shall be replaced by NZS 3101⁽¹⁾ and New Zealand Transport Agency *Bridge manual*.

Within clause 6.2.4, the design life of the bridge shall be taken to be as specified in 2.1.5 of this manual.

Within clauses 10.6.1.2, 10.6.1.4, and 10.6.1.5, concrete of normal weight may conform with NZS 3101⁽¹⁾ as an alternative to AS 5100.5⁽⁹⁾, and reinforcement may be designed and detailed in accordance with NZS 3101⁽¹⁾ as an alternative to AS 5100.5⁽⁹⁾. Where longitudinal reinforcement is placed in contact with the steel section as shown in figure 10.6.1.4, the bond associated with reduction in the effective perimeter of the bar may be similarly determined based on NZS 3101⁽¹⁾.

Within clause 10.6.2.3, if δ is less than 0.2 the column may be designed as a reinforced concrete column in accordance with NZS 3101⁽¹⁾, as an alternative to AS 5100.5⁽⁹⁾.

Within clause 10.6.2.4, creep coefficients (φ_{cc}) appropriate to New Zealand concrete as determined from NZS 3101⁽¹⁾ shall be applied in place of values determined from AS 5100.5⁽⁹⁾. Note that the compression member's elastic flexural stiffness should only be modified for creep for the effects of sustained long term loading inducing flexure in the member.

Within clause 10.8.3.4, shrinkage strains (ε_{cse} or ε_{cs}) appropriate to New Zealand concrete as determined from NZS 3101⁽¹⁾ shall be applied in place of values determined from AS 5100.5⁽⁹⁾.

g. Design for longitudinal shear (clauses 6.8.3.2 and 6.8.5.2.1)

Within clause 6.8.5.2.1, no reliance shall be placed on cohesion contributing to the shear strength as it is considered to be unreliable. k_{co} shall be taken as zero for all surface conditions. The higher coefficients of friction (μ) specified by NZS 3101⁽¹⁾ clause 7.7.4.3 may be adopted in place of those specified by table 6.8.5.2.1.

h. Members subjected to axial tension (clause 9.2.1)

Within clause 9.2.1 add to the definition for A_n : "For threaded rods, the net area shall be taken as the tensile stress area of the threaded portion as defined in AS 1275."

i. Members subjected to axial compression - correction of terminology (section 10)

Correct terminology within this section as follows:

Within clauses 10.1, and 10.2.1 in the definitions of N_{us} and N_{uc} replace "nominal section capacity" with "design (dependable) section capacity at the ultimate limit state" and "nominal member capacity" with "design (dependable) member capacity at the ultimate limit state" respectively.

Amend the heading of clause 10.3.3 to "Design (dependable) capacity of a member of constant cross section" and within the first paragraph of the clause replace "ultimate member capacity (N_{uc})" with "design (dependable) member capacity (N_{uc}) at the ultimate limit state".

4.3.3 continued

Amend the heading of clause 10.6.2 to “Design (dependable) section capacity at the ultimate limit state” and within the first paragraph of clauses 10.6.2.1 and 10.6.2.2 replace “ultimate section capacity (N_{us})” with “design (dependable) section capacity (N_{us}) at the ultimate limit state”. Within the first paragraph of 10.6.2.3 insert “design (dependable)” before “plastic resistance”.

Amend the heading of clause 10.6.3 to “Design (dependable) member capacity at the ultimate limit state”.

Amend the heading of clause 10.6.3.3 to “Design (dependable) member capacity at the ultimate limit state of composite members of constant cross section” and within the first paragraph of clause 10.6.3.3 replace “nominal member capacity (N_{uc})” with “design (dependable) member capacity (N_{uc}) at the ultimate limit state”, and in the definition of N_{us} replace “nominal section capacity” with “design (dependable) section capacity at the ultimate limit state”.

Amend the heading of clause 10.6.3.4 to “Design (dependable) member capacity at the ultimate limit state of composite members of varying cross section”. Within the first paragraph of clause 10.6.3.4 replace “nominal member capacity (N_{uc})” with “design (dependable) member capacity (N_{uc}) at the ultimate limit state”, and in (a) replace “nominal section capacity (N_{us})” with “design (dependable) section capacity (N_{us})”.

j. Members subject to combined actions (section 11)

The additional constraints imposed by NZS 3404:1997⁽²³⁾ clause 8.1.5 in respect to clause 8.3.4.2 shall apply to the use of the alternative method of AS/NZS 5100.6⁽²⁴⁾ clause 11.3.4.

For requirements for double bolted or welded single angles eccentrically loaded in compression, omitted from section 11, refer to NZS 3404:1997⁽²³⁾ sub-section 8.4.6.

Delete from the heading of sub-section 11.5 the word “compression” as the sub-section also considers tension combined with bending.

k. Connections (section 12)

Within clause 12.2.7, amend the definitions of snug tight as follows: “The tightness of a bolt achieved by a few impacts of an impact wrench or by the full effort of a person using a podger spanner to ensure that the load transmitting plies are brought into effective contact.”

Within clause 12.3.1, replace the first paragraph with: “Connections carrying calculated design actions, except for lacing connections, shall be designed to transmit the greater of the design action in the member and the following minimum actions: ”

Within clause 12.3.4, replace the first sentence of the second paragraph with: “Where a mixture of non-slip fasteners is used, sharing of the load may be assumed except in connections forming part of a seismic resisting system in which the sharing of actions on the same element between welds and bolts is not permitted.”

To clause 12.3.6 add a second paragraph: “When using Sections 9 and 10 for the design of connection components, take $\alpha_b = 0.5$ and determine the net area (A_n) by means of a rational design procedure which accounts for the distribution of axial force into the component.”

4.3.3 continued

Within clause 12.5.3.4 merge the last sentence of the clause to the definition of a_e , to read:

" a_e = minimum distance from the edge of a hole to the edge of a ply, measured in the direction of the component of the force, plus half the bolt diameter. The edge of a ply shall be deemed to include the edge of an adjacent bolt hole."

With reference to clause 12.5.4.1, tests in accordance with NZS 3404:1997⁽²³⁾ clause 9.3.3.2.1 and appendix K to determine the slip factor for friction type connections in shear are an acceptable alternative to those specified by AS 4100 *Steel structures*⁽³¹⁾.

Within clause 12.6.8.1, replace the paragraph with: "Plug and slot welds may only be used to transmit shear in lap joints or to prevent buckling of lapped parts or to join component parts of built up members or to prevent out of plane buckling of doubler plates in joint panel zones."

Within clause 12.6.10.1, add as a second paragraph to (a): "The butt weld shall be made using welding consumables that will produce butt tensile test specimens in accordance with AS 2205.2.1 for which the minimum strength is not less than the corresponding values for the parent material."

l. Fatigue loading (section 13)

Within clause 13.5, amend (a) as follows: "no appropriate fatigue load is available in AS 5100.2 or the NZTA *Bridge manual*, or"

Use of the damage tolerant fatigue assessment method as presented by clause 13.6.2 shall not be adopted as the basis for design for fatigue.

Within clauses 13.9.2.1, 13.9.3 and 13.9.4, reference to AS 5100.2⁽³⁰⁾ shall be replaced by New Zealand Transport Agency *Bridge manual*. The dynamic load allowance (α) shall be taken as the dynamic load factor from figure 3.2 of this manual minus 1.0.

m. Brittle fracture resistance (section 14)

Within clause 14.3, add to the end of the second paragraph: "The steel grade shall be selected to match the required steel type in accordance with 14.5.4."

Within table 14.5.1, replace the permissible service temperatures for steel types 2S and 5S with the following permissible service temperatures for these steel types:

Steel type	Permissible service temperature, °C					
	Thickness, mm					
	≤6	>6 ≤12	>12 ≤20	>20 ≤32	>32 ≤70	>70
2S & 5S	-35	-25	-15	-10	-10	-5

Within clause 14.5.3.4, replace paragraphs (b) and (e) with the following:

"(b) Three Charpy test specimens shall be taken from the area of maximum strain and tested at the design service temperature or lower."

"(e) Where a plate or component thickness prevents a 10 mm x 10 mm test piece from being used, the standard test specimen thickness given in Appendix K Table K4 closest to the plate or component thickness shall be used. Where the standard to which the steel complies does not specify minimum impact properties, the average absorbed energy for three test specimens and the minimum absorbed energy of each specimen shall be not less than those given in Table K4 for the relevant size of test specimen."

4.3.3 continued

Within clause 14.5.4, following the first sentence add: "For steels conforming to BS EN 10025 and JIS G 3106 refer to Table H4.1 or NZS 3404:1997 Table 2.6.4.4."

At the end of clause 14.5.4 add the following two paragraphs:

"Welding consumables selection shall be in accordance with AS/NZS 1554.1 or AS/NZS 1554.5.

The impact resistance of bolts must not be less than that for the grades of steel that they are joining."

n. Proof testing (sub-section 15.3)

Replace sub-section 15.3 with: "Proof load testing shall comply with Clause 7.6 of the New Zealand Transport Agency *Bridge manual*."

4.3.4 Seismic resistance

Where materials design codes other than NZS 3404:1997⁽²³⁾ are applied, if steel members are required to provide the ductility and energy dissipating capability of the structure, the principles set out in section 12 of NZS 3404:1997⁽²³⁾ shall be followed. The recommendations of the NZNSEE study group on *Seismic design of steel structures*⁽³²⁾ shall also be followed where applicable.

4.3.5 Fatigue design

Assessment of the fatigue resistance of steel structure components shall be based on the respective design standard adopted for the design of the component as per 4.3.1. For comment on the fatigue loading see 3.2.6 of this document.

4.3.6 Durability and corrosion protection

a. Corrosion protection systems

Corrosion protection systems for structural steelwork shall comply with *Protective coatings for steel bridges: a guide for bridge and maintenance engineers*⁽³³⁾ and the relevant part of AS/NZS 2312 *Guide to the protection of structural steel against atmospheric corrosion by the use of protective coatings*⁽³⁴⁾, and SNZ TS 3404 *Durability requirements for steel structures and components*⁽³⁵⁾.

Primary structural members and elements not easily accessed or replaced (eg bearing plates, deck joint components) in steel shall be corrosion protected with a system capable of achieving a time to first maintenance of at least 40 years unless agreed otherwise with the road controlling authority.

Secondary steelwork elements (eg barriers, handrails) shall be corrosion protected with a system capable of achieving a time to first maintenance of at least 25 years.

The terminology "time to first maintenance" and "time to first major maintenance" shall be taken to have the same meaning and to be as defined by SNZ TS 3404⁽³⁵⁾ clause 1.7. Additional guidance on the selection of corrosion protection systems, in particular for those systems capable of achieving an expected life to first maintenance of in excess of 40 years, is given in *Protective coatings for steel bridges: a guide for bridge and maintenance engineers*⁽³³⁾, the New Zealand Heavy Engineering Research Association (HERA) report R4-133 *New Zealand steelwork corrosion and coatings guide*⁽³⁶⁾ and SNZ TS 3404⁽³⁵⁾. Where the corrosivity of the environment is such that achieving the above levels of performance is impractical or not economically viable, a lower level of performance may be proposed and justified within the structure design statement.

Linkage bars and hold-down devices providing interconnection between the primary elements of the structure as per 2.1.7 shall satisfy the durability requirements of 2.1.6 and appendix C clause C1.6.

4.3.6 continued

For steelwork coloured for aesthetic purposes (ie colours other than the generic grey from metallic coatings, such as thermal metal spray or galvanizing), the coloured top coat will typically require refurbishment every 10-15 years depending on the chosen colour and coating selected. As such, it is accepted that the time to first maintenance of at least 40 years is not achievable and a lower level of performance may be proposed. This will require approval from the road controlling authority for this departure from the requirements of this manual.

Thermal metal spray systems shall be seal coated as recommended in AS/NZS 2312⁽³⁴⁾ to give uniformity of appearance and increase durability.

b. Weathering steel

The design and detailing of weathering steel bridges shall be undertaken in accordance with HERA's *Design guide for bridges in Australia - Weathering steel*⁽³⁷⁾, except that material from sources other than BlueScope Steel Ltd, to other standards besides AS/NZS 3678⁽¹⁶⁾, is permitted as outlined below. The previous guidance given in HERA report R4-97 *New Zealand weathering steel guide for bridges*⁽³⁸⁾ related to the minimum distances from the sea, has been superseded by section 2.3.1 of *Design guide for bridges in Australia - Weathering steel*⁽³⁷⁾. Subject to obtaining any approval required, as outlined below, and confirming that the site corrosivity is less than or equal to an ISO 9223 *Corrosion of metals and alloys - Corrosivity of atmospheres - Classification, determination and estimation*⁽³⁹⁾ atmospheric corrosivity category of C3 (Medium), taking into account both the macro- and microclimate as per HERA report R4-133⁽³⁶⁾, regardless of the distance from the sea, weathering steel may be used. The requirement in section 2.3.3 of *Design guide for bridges in Australia - Weathering steel*⁽³⁷⁾ for the humidity level at the site to be less than 80% for more than 40% of the year is also now considered to be not appropriate and shall not apply.

Furthermore, the guidance given in Section 1.3.3 of HERA Report R4-97⁽³⁸⁾ in relation to the relative humidity limits shall not be used. The effects of relative humidity are taken into account when using the atmospheric corrosivity category limits discussed above.

For weathering steel plate supplied to international standards, other than to AS/NZS 3678⁽¹⁶⁾, these shall comply with a relevant materials standard given in NZS 3404.1:2009⁽²⁶⁾ and/or AS/NZS 5100.6⁽²⁴⁾.

This includes ensuring that welding consumables shall be suitable for the nominated grade of weathering steel. The contractor shall certify that the welded metal meets, or exceeds, the specified minimum mechanical properties of the parent metal. The type of welding consumable proposed for use shall be identified on the weld procedure required for each type of weld.

For locations where the atmospheric corrosivity environments (macro and microclimates) are greater than C3 (medium), ie is C4 (high) or C5 (very high), proprietary 'coastal weathering steel' grades with a higher nickel content may be suitable and more appropriate. Due to the limited availability of detailed technical guidance for use of this material in the New Zealand environment at this point in time (2018), prior approval from the road controlling authority will be required.

4.3.6 continued

As a prerequisite for approval a 12-month site specific corrosivity study (to ASTM G50 *Standard practice for conducting atmospheric corrosion tests on metals*⁽⁴⁰⁾) shall be carried out of coastal weathering steel coupons of the same material being considered exposed to both rain washed and sheltered conditions. This shall be reviewed by an Engineers NZ chartered materials engineer and/or NACE corrosion specialist, who will in turn recommend whether it can be used in the proposed location. The design engineer and contractor will also need to ensure the selection of both welding consumables and bolts that provide the same level of durability as the nominated weathering steel, by supplying confirmation in writing from the manufacturer.

In addition, the following requirements shall be complied with:

- The weathering steel shall be resistant to brittle fracture and lamellar tearing in accordance with section 14 of AS/NZS 5100.6⁽²⁴⁾.
- Electrodes used for welding shall be of comparable weathering properties to that of the parent metal. For each type of electrode used, a test sample shall be made of a 10mm fillet weld on the parent weathering steel and tested to ensure that the weld metal's chemical composition is within the allowable range specified in the relevant standard for the parent metal.
- After fabrication and prior to erection, all weathering steel components shall be abrasive blast cleaned with non-metallic grit to SSPC SP 6/NACE No. 3 *Commercial blast cleaning*⁽⁴¹⁾ to remove mill scale and other contaminants. This shall be immediately followed by a minimum of three cycles of wetting using potable water and drying, to assist in the formation of the protective patina and provide a uniform finish. In the event of fabrication being undertaken offshore from New Zealand, this shall be undertaken following delivery to New Zealand of the fabricated steelwork.

4.3.7 Certification of steel

All steel, bolts, nuts and washers shall comply with the requirements of AS/NZS 5131⁽²⁵⁾ and standards listed therein. Additional acceptable compliance standards to those listed in AS/NZS 5131⁽²⁵⁾, acceptable for compliance to, for specific materials, are:

- For nuts: AS 1112 *ISO metric hexagon nuts*⁽⁴²⁾
- For washers: AS 1237.1 *Plain washers for metric bolts, screws and nuts for general purposes – General plan*⁽⁴³⁾
- For high tensile bars: BS 4486 *Specification for hot rolled and hot rolled and processed high tensile alloy steel bars for the prestressing of concrete*⁽⁴⁴⁾

Evidence of compliance with the specified standards shall be obtained and shall comprise test reports or test certificates prepared by a laboratory recognised by signatories to the International Laboratory Accreditation Cooperation (ILAC) Mutual Recognition Agreement (MRA) on behalf of the manufacturer. These documents are to be traceable to the specific batches of material used.

Alternatively for fasteners, an IANZ (International Accreditation New Zealand) endorsed proof load and wedge test certificate showing they comply with the specified standard may be provided.

The requirements for the specification of structural steel, its supply and compliance are currently undergoing review and revision. In addition to the above current requirements note shall be taken of any Technical Advice Note published by the NZ Transport Agency dealing with this subject (TAN #17-09 *Verification testing of steel materials* at the time of publication) and the mandatory requirements set out therein shall be complied with.

Construction categories as nominated in AS/NZS 5131 shall be in accordance with any Technical Advice Note published by the NZ Transport Agency dealing with this subject; or any project principal's requirements; or as otherwise agreed with the road controlling authority and as detailed in the structure design statement.

4.4 Timber

4.4.1 General

Design shall be in accordance with the appropriate following standards, except as modified by 4.4.2:

- AS 5100.9 *Bridge design* part 9 Timber⁽⁴⁵⁾
- NZS 3603 *Timber structures standard*⁽⁴⁶⁾ for the timber species and types of timber materials that it covers that are not covered by AS 5100.9⁽⁴⁵⁾
- AS 1720.1 *Timber structures* part 1 Design methods⁽⁴⁷⁾ for the timber species and types of timber materials that it covers that are not covered by AS 5100.9⁽⁴⁵⁾ or NZS 3603⁽⁴⁶⁾
- Characteristic stresses adopted for design to AS 1720.1⁽⁴⁷⁾ shall be in accordance with AS 1720.2 *Timber structures* part 2 Timber properties⁽⁴⁸⁾ and AS/NZS 2878 *Timber - Classification into strength groups*⁽⁴⁹⁾.

4.4.2 Strength reduction factors, characteristic stress/strength modification factors and live load factor

Strength reduction factors shall conform to those given in AS 5100.9⁽⁴⁵⁾ table 3.2 corresponding to the type of timber product and/or jointing being considered. Where not covered by AS 5100.9⁽⁴⁵⁾, strength reduction factors shall be derived from AS 1720.1⁽⁴⁷⁾ table 2.1, corresponding to the type of timber product (eg sawn timber, round timbers) and type of grading (eg visually graded, machine graded, proof graded) and/or jointing being considered. For secondary structural elements they shall be those for AS 1720.1⁽⁴⁷⁾ table 2.1 category 2 structural members and joints, and for primary structural elements they shall be those for AS 1720.1⁽⁴⁷⁾ table 2.1 category 3 structural members and joints.

For the grid system or parallel support system modification factor (k_4 , k_5 or k_6 in NZS 3603⁽⁴⁶⁾ or k_9 in AS 1720.1⁽⁴⁷⁾) to apply, in the event of the failure of a single supporting member, the overlying members or sheathing material shall be capable of transferring loads to the adjacent supporting members. Otherwise the grid system or parallel support system modification factor shall be taken as 1.0.

Where a bridge or other structure possesses smooth sealed approaches the live load dynamic load factor may be taken as follows:

$$\text{Dynamic load factor} = 1.0 + (I - 1.0) \times 0.7$$

Where I is the dynamic load factor defined by 3.2.5.

4.4.3 Seismic resistance

Design shall comply with NZS 3603⁽⁴⁶⁾ clause 2.12 for seismic resistance except that the design loading shall be in accordance with this document.

4.4.4 Durability

In order to ensure long-term durability in timber bridge members, particular attention shall be given to the provisions of AS 5100.9⁽⁴⁵⁾ section 4 in general, and for stress laminated timber, of AS 5100.9⁽⁴⁵⁾ section 5, and to the following:

- in-service moisture content and the effects of its variation
- member deflections
- connection design.

4.5 Aluminium

Design shall be in accordance with AS/NZS 1664.1 *Aluminium structures* part 1 Limit state design⁽⁵⁰⁾ with the following provisos:

a. Loading (clause 2.3)

The loads on the structure shall be in accordance with this document.

b. Loading combinations and load factors (clause 2.4)

The required forces, moments and stresses for the applicable loads shall be determined by structural analysis for the load combinations as indicated in this document.

c. Earthquake (clause 2.5)

All structures shall be designed for the loads and load combinations specified in this document. The limitations on structural ductility factor given in AS/NZ 1664.1⁽⁵⁰⁾ clause 2.4(b)(i) and (ii) shall apply. The structural performance factor (S_p) shall be as specified in this document.

4.6 Other materials

The criteria applying to the use of materials not mentioned in this document will be subject to the approval of the road controlling authority.

4.7 Bearings and deck joints

4.7.1 General

a. Design code

The design and performance of bearings and deck joints shall comply with AS 5100.4 *Bridge design* part 4 Bearings and deck joints⁽⁵¹⁾ except as modified herein. Where there may be conflict between the requirements of AS 5100.4⁽⁵¹⁾ and this document, this document shall take precedence.

b. Preferred bearing types

Bridge bearings shall preferably be elastomeric bearings. Where mechanical bearings are used they shall be pot or spherical approved sliding material (ASM) bearings (including sliding or sliding guided pot and spherical ASM bearings). Alternative bearing types may be considered provided their equivalence to that specified can be demonstrated to the satisfaction of the road controlling authority. Roller bearings shall not be used.

c. Elastomeric bearings

Reference to elastomeric bearings herein shall also include laminated elastomeric bearings fitted with a lead cylinder, commonly referred to as lead-rubber bearings, used for the dissipation of earthquake energy.

d. Deck joints

The number of deck joints in a structure shall be the practical minimum.

4.7.1 continued

In principle, deck slabs should be continuous over intermediate supports, and bridges with overall lengths of less than the limits specified by 4.8.2(a) and skews of less than 30° should have integral or semi-integral abutments. It is accepted that deck joints may be necessary in longer bridges to cater for periodic changes in length. They may also be necessary where the structural system, adopted with the objective of minimising earthquake damage (eg base isolation with mechanical energy dissipation, or rocking piers), requires the structure to be free to displace.

The form of deck joints to be used shall be nominated in the structure options report or structure design statement and shall be subject to the approval of the road controlling authority. For bridges requiring deck joint gaps exceeding 25mm, the NZTA's preferred form of deck joint is the single elastomeric seal retained by metal nosings. For very long bridges where appropriate, single seal deck joints at maximum spacing along the bridge length are preferred to multiple seal joints.

Should deck joints possessing aluminium nosings be proposed to be used, evidence shall be provided to substantiate their durability and robustness to withstand their service conditions and acceptance of their use obtained from the road controlling authority.

e. Access and provision for inspection, maintenance and repair

Access and provisions for inspection, maintenance and repair of bearings and deck joints shall comply with 2.1.9.

4.7.2 Modifications and extensions to the AS 5100.4⁽⁵¹⁾ criteria for bearings

a. Limit state requirements and robustness

Elastomeric, lead-rubber, pot and spherical ASM bearings shall be designed for the serviceability, ultimate and seismic damage control limit states.

The robustness and displacement capacity of bearings and their fixings shall be checked at the damage control limit state, and shall also be sufficient to ensure that sufficient overall integrity of the structure is maintained and collapse avoided under seismic response from a major earthquake (see table 5.1).

b. Bearings inspection and replacement

All bearings, other than thin elastomeric strip bearings less than 25mm in thickness, shall be able to be inspected and replaced without the removal of any structural concrete or cutting of steelwork.

Provision shall be made in the design for jacking from the substructure sills on which the beams are supported during bearing replacement. Replacement of bearings shall be possible with minimal disruption to traffic on the bridge, or to traffic beneath the bridge.

c. Design loads and movements and load factors

Reference in AS 5100.4⁽⁵¹⁾ to design loads and load factors given in AS 5100.2⁽³⁰⁾ shall be replaced by reference to chapter 3 of this manual. For limits on movement and restraint of movement see AS 5100.4⁽⁵¹⁾.

The potential variability in coefficients of friction of sliding surfaces and in the stiffnesses of elastomeric bearings shall be taken into account with the effect of both upper and lower bound values for these being considered in the design.

4.7.2 continued

In the design of sliding contact surfaces incorporating PTFE, the coefficient of friction to be used for analysis shall be assessed on a conservative basis for the situation being considered. 0.02 shall be assumed as the coefficient of friction for situations where a minimum frictional force is appropriate. For situations where a maximum frictional force is appropriate a coefficient of friction of at least 0.15 shall be assumed. The following shall also be given consideration:

- the guidance provided by section 14.7.2 of the AASHTO *LRFD Bridge design specifications*⁽¹⁷⁾, and associated commentary
- that initial static friction is generally significantly higher than the friction acting after sliding has initiated
- that friction values may be as much as 5 to 10 times higher at sliding speeds anticipated under seismic loads compared to the coefficients under thermal expansion (as noted by Caltrans *Seismic design criteria*⁽⁵²⁾).

The upper and lower bound stiffnesses adopted in design for elastomeric bearings shall be consistent with the manufacturing tolerances specified for their shear and compression stiffnesses. $\pm 25\%$ has typically been applied as the specified manufacturing tolerances for these stiffnesses and shall be adopted unless tighter tolerances are to be specified for the manufacture of the bearings.

d. Anchorage of bearings

Bearings, other than thin elastomeric strip bearings less than 25mm in thickness, shall be positively anchored to the bridge structure above and below to prevent their dislodgement during response to the damage control limit state design intensity or greater earthquake unless the bridge superstructure is fully restrained by other means against horizontal displacement relative to the support. Reliance shall not be placed on friction alone to ensure safety against sliding. The bearing restraint system for horizontal load shall be designed to resist the full horizontal force to be transmitted by the bearing from the superstructure to the substructure.

For laminated elastomeric bearings, horizontal restraint shall be provided by dowels or bolts engaging in thick outer shims within the bearing or by vulcanising the bearings to external plates that are fixed in position to the structure by bolts. External restraining cleats shall not be used. Dowels shall generally be located as close to the centre of the bearing (in plan) as practicable, to prevent them from disengaging due to deformation of the edges of the bearing under the high shear strain that may be developed during response to a strong earthquake.

Bearings shall be mounted on either cast concrete or proprietary shrinkage compensated mortar having a 28-day compressive strength of at least 50MPa. A smooth surface on the supporting concrete or mortar shall surround the bearing and have a dimension from the edges of the bearing of at least the height of the bearing.

Dowels, as a means of bearing lateral restraint, do not need to be removable to allow bearing replacement provided that the bridge superstructure can be jacked sufficiently to enable the bearings to be lifted, disengaged from the restraining dowels, and slid out of position.

e. Bearing set back from the edge of concrete bearing surfaces and confinement of bearing surfaces

Bearings shall be set sufficiently far back from the edge of concrete bearing surfaces to avoid spalling of the corner concrete, and where bearing pressures are high, confining reinforcement shall be provided to prevent tensile splitting of the concrete. Consideration shall be given to the redistribution of pressure on the concrete bearing surface due to horizontal loads such as from earthquake action.

4.7.2 continued

f. Elastomeric bearings

Elastomeric bearings shall conform with the requirements of AS 5100.4⁽⁵¹⁾, except that steel reinforcing plates may be a minimum of 3mm thick.

Wherever feasible, bearings shall be chosen from those commercially available, but this does not preclude the use of individual designs where circumstances justify it.

Under service conditions that exclude earthquake effects and collision loading, the maximum shear strain in a bearing (measured as a percentage of the total rubber thickness being sheared) shall not exceed 50%. Under response to the damage control limit state design intensity earthquake and ultimate limit state collision loading, plus other prevailing conditions such as permanent loads and shortening effects, corresponding to table 3.2 load combinations 3A and 3C, the maximum shear strain shall not exceed 100%.

In the design of elastomeric and lead-rubber bearings, the following considerations shall be given particular attention:

- In evaluating the stability against roll-over, consideration shall be given to the sensitivity of the stability to an extreme earthquake such as the collapse avoidance limit state event, as safety factors can be rapidly eroded.
- In bridges with prestressed concrete superstructures and the spans either continuous or tightly linked, consideration shall be given to the long-term effects of shrinkage and creep shortening of the superstructure due to the prestress on the bearings.

g. Sliding bearings

Bearings containing sliding surfaces shall have the sliding surfaces protected from dirt and debris ingress that may affect the performance of the bearing.

h. Design life

In respect to bearings, AS 5100.4⁽⁵¹⁾ clause 7.3 shall be replaced with the following:

Bearings shall satisfy the requirements of 2.1.6(b) which includes a minimum service life of 40 years. Cast in components shall have the same design life as the bridge.

i. Testing of laminated elastomeric bearings

Testing of laminated elastomeric bearing, with or without lead plugs, shall comply with AS 5100.4⁽⁵¹⁾ appendix D extended and modified as follows:

All bearings shall be tested for stiffness in compression. If the results are consistent within $\pm 10\%$ of the mean, not less than one quarter of the bearings of each type, and in any case not less than four from each order, shall be tested for stiffness in shear. If the compression stiffness of the bearings tested is inconsistent (ie variation greater than $\pm 10\%$ of the mean), all bearings shall be tested for stiffness in shear.

Test stiffness in compression and shear shall be within $\pm 20\%$ of the values specified by the designer and in addition shall be within $\pm 15\%$ of the mean of all test results for each type of bearing. Any test result outside of these tolerances shall make that bearing liable for rejection.

The "rated load" for testing of the bearings in compression shall be taken as the bearing rated load for the *Bridge manual* table 3.1 load combination 1A type design loading with zero bearing shear deflection.

4.7.2 continued

For bearings loaded in shear by earthquake loading, the “rated load” for the test of stiffness of the bearing in shear shall be taken as the bearing rated load for load combination 3A type design loading with a bearing shear deflection equal to the “rated shear deflection” (RSD). The “rated shear deflection” for the test of stiffness in shear shall be taken as the total rubber thickness.

For bearings not loaded in shear by earthquake loading, the “rated load” for the test of stiffness of the bearing in shear shall be taken as the bearing rated load for load combination 1A type design loading with a bearing shear deflection equal to the “rated shear deflection”. The “rated shear deflection” for the test of stiffness in shear shall be taken as 0.5 times the total rubber thickness.

The shear stiffness test method specified by AS 5100.4⁽⁵¹⁾ clause D4.2 shall be modified as follows:

Replace (c) and (f) with: Load the bearing in compression to the rated load for the stiffness test.

Replace (d) with: While maintaining the compressive load, apply shear loads to the plate in a direction parallel to the short dimension of the bearings. Increase the shear load at a uniform rate of 25mm/minute from zero shear to 1.25 times the rated shear deflection and maintain shear load for one minute. Then take and record a reading of the shear load.

Replace (h) with: While maintaining the compressive load, reapply the shear load at the uniform rate of 25mm/minute taking readings of the shear load at 0.2, 0.5 and 1.0 times the rated shear deflection. At each reading level, maintain the shear deflection for 30 seconds prior to taking the shear load reading. Then deflect the bearings in shear to 2.0 times the rated shear deflection for bearings loaded in shear by earthquake, or to 1.5 times the rated shear deflection for bearings not loaded in shear by earthquake, and inspect the bearings for faults such as misplaced steel plates, bond failure, and surface defects (eg tears or splits).

Replace (i) with: The stiffness of the individual bearings shall be calculated for two shear deflections ranges thus:

- i. (shear load increment applied to the pair of bearings between 0.2xRSD and 0.5xRSD)
(2x0.3xRSD)
- ii. (shear load increment applied to the pair of bearings between 0.2xRSD and 1.0xRSD)
(2x0.8xRSD)

The chord shear modulus G shall be calculated in accordance with 12.7.2 of AS 5100.4⁽⁵¹⁾.

4.7.3 Modifications to the AS 5100.4⁽⁵¹⁾ criteria for deck joints

a. General requirements

The maximum opening of a deck joint will generally be determined by earthquake conditions at the damage control limit state. No limitation applies to the maximum design width of an open gap joint under these conditions.

The maximum width of open gap between expansion joint components at deck surface level, at the ultimate limit state, under non-seismic load combinations in table 3.2, shall not exceed 85mm.

Where pedestrians, cyclists or animals have direct access over deck joints, all open gap deck joints shall be sealed or covered, but deck joints otherwise do not need to be covered.

4.7.3 continued

b. Design loads

Deck joints and their fixings shall be designed for the following loads in place of those specified by the AS 5100.4⁽⁵¹⁾:

i. Vertical at ultimate limit state

The vehicle axle loads defined in 3.2.2 factored by the dynamic load factor defined in (iv). The ultimate limit state load factors to be applied shall be 2.25 to an HN axle load, and 1.49 to an HO axle load.

ii. Vertical at serviceability limit state

The HN vehicle axle load defined in 3.2.2 factored by the dynamic load factor defined in (iv) together with a serviceability limit state load factor of 1.35.

iii. Fatigue

The HN vehicle axle load defined in 3.2.2 factored by the dynamic load factor defined in (iv) together with a load factor of 0.80.

iv. Dynamic load factor

A dynamic load factor shall be applied to the ultimate limit state and serviceability limits state vertical loads and the fatigue load. The dynamic load factor to be applied shall be taken as 1.60 except for modular bridge expansion joints for which it shall be derived as 1.0 plus the dynamic amplification factor (DAF) determined in accordance with AS 5100.4⁽⁵¹⁾ clauses 20.3.9 and 20.3.10.

v. Longitudinal

The local vehicle braking and traction forces specified in 3.3.1, combined with any force due to the stiffness of, or friction in, the joint. The ultimate limit state load factor to be applied to the combined force shall be 1.35.

c. Movements

i. Deck joints shall be designed to accommodate the movements due to temperature, shortening and earthquake specified in 5.7.1 and to otherwise satisfy the requirements of 5.7.1.

ii. Deck joints shall be designed to accommodate the ultimate limit state movements from table 3.2 load combinations, except those for load combination 3A (seismic), and shall include the effect of beam end rotation under live load.

d. Anchorage

The second paragraph of AS 5100.4⁽⁵¹⁾ clause 19.4 shall be replaced by the following:

Where the deck joint is attached by bolts, fully tensioned high tensile bolts of property class 8.8 or higher shall be used. The spacing of the bolts shall not be greater than 300mm and the bolts shall develop a dependable force clamping the joint to the concrete substrate, of not less than 500kN per metre length on each side of the joint.

Where appropriate, deck joint anchor bolts shall be sleeved through the deck and anchored on the underside with nuts & locknuts. Such hardware shall be replaceable.

e. Drainage

The AS 5100.4⁽⁵¹⁾ clause 19.5 shall be replaced by the following:

4.7.3 continued

Deck joints shall be watertight unless specific provision is made to collect and dispose of the water. Deck run-off shall be contained from spilling over the sides of the bridge. Sealed expansion joints, where the gap is sealed with a compression seal, elastomeric element or sealant, are preferred.

Open joints, where the gap is not sealed, shall be slightly wider at the bottom than at the top to prevent stones and debris lodging in the joint, and shall include a specific drainage system to collect and dispose of the water. Such drainage systems shall be accessible for cleaning.

The design of drainage systems shall accommodate a serviceability limit state movement across the deck joints of the bridge of not less than the greater of:

- one quarter of the calculated relative movement under the damage control limit state design earthquake conditions, plus long-term shortening effects where applicable, and one third of the temperature induced movement from the median temperature position; and
- long term shortening plus the full design temperature induced movement from the median temperature position

without sustaining damage. Under greater movements, the drainage system shall be detailed so that damage is confined to readily replaceable components only.

f. Installation

Deck joints and the parts of the structure to which they are attached shall be designed so that the joint can be installed after completion of the deck slab in the adjacent span(s).

g. Design life and provision for access, resetting and replacement

In respect to deck joints, AS 5100.4⁽⁵¹⁾ clause 7.3 shall be replaced with, and clauses 7.6, 7.7 and 7.9 modified by, the following:

Deck joints, with the exception of modular bridge expansion joints, shall satisfy the requirements of 2.1.6(b) which includes a minimum service life of 40 years. Cast in components shall have the same design life as the bridge. Notwithstanding the requirements of 2.1.6(b) for movement joints as a whole, replaceable elastomeric seal components of joints shall have a minimum service life of 15 years and shall be replaceable without the need for modification to the joint and adjacent structural elements. Modular bridge expansion joints shall satisfy the service life requirements of AS 5100.4⁽⁵¹⁾ clause 20.3.2.

Asphaltic plug (elastomeric concrete) joints have a limited service life and are highly unlikely to meet the minimum life of 40 years for replaceable deck joint components specified by 2.1.6(b). The use of this form of deck joint in high traffic environments shall be avoided where possible and otherwise shall be subject to the approval of the road controlling authority.

In general most forms of large movement deck joints can be subject to deterioration and eventual failure within the design life of a bridge. Consideration shall be given to, and provision shall be made for, the eventual need to reset or replace deck joints in the design of the structure supporting the deck joint, including the provision of adequate access to facilitate the deck joint inspection, maintenance, and resetting or replacement. This applies especially to multiple seal modular deck joints and forms of deck joint involving mechanical componentry and below joint surface drainage systems.

4.7.4 Additional criteria and guidance for deck joints

a. Joint type and joint system selection

Movement joints shall be selected on the basis of low life-time costs and maintenance requirements, and user (vehicle, cyclist and pedestrian) safety.

Deck joints shall be designed to provide for the total design range and direction of movement expected for a specific installation. The guidance provided by *BD 33 Expansion joints for use in highway bridge decks*⁽⁵³⁾ shall be considered with respect to the movement capacity of common joint types.

Acceptance of a proprietary joint system shall be subject to that system satisfying the requirements of this manual and the additional project-specific performance requirements. All dimensional and performance requirements, including movement capacity, shall be specified in the design to enable manufacturers to offer joints that are best suited to meet the requirements.

The characteristics and performance history of a particular joint shall be reviewed to determine the suitability of the joint for a specific installation. The information provided in *Performance of deck expansion joints in New Zealand road bridges*⁽⁵⁴⁾ and *Bridge deck expansion joints*⁽⁵⁵⁾ shall be considered with respect to the performance history of deck joints.

Proprietary deck joint suppliers shall provide a warranty on the serviceability (ie durability and performance) of their joint(s) for a period of ten years after installation. The warranty shall cover all costs associated with rectification of a joint, including traffic control costs.

b. Joint sealing elements

Joint sealing elements (eg compression seals, elastomeric membrane seals, sealants) shall be resistant to water, oil, salt, stone penetration, abrasion and environmental effects, and shall be readily replaceable. Compression seals shall not be used in situations where concrete creep shortening and/or rotation of the ends of beams under live loading will result in decompression of the seal.

Sealants shall be compatible with the materials with which they will be in contact. It is typically necessary to provide a separation barrier between sealant and bituminous deck surfacing. Irrespective of claimed properties, sealants shall not be subjected to more than 25% strain in tension or compression. The modulus of elasticity of the sealant shall be appropriate to ensure that, under the expected joint movement, the tensile capacity of the concrete forming the joint is not exceeded. The joint shall be sealed at or as near the mean of its range of movement as is practicable. Base support for joint sealants shall be provided by durable compressible joint fillers with adequate recovery and without excessive compressive stiffness.

Joint seals or sealant shall be set 5mm lower than the deck surface to limit damage by traffic.

c. Nosings

New bridges and deck replacements shall be designed with a concrete upstand the height of the carriageway surfacing thickness and at least 200mm wide between the deck joint and the adjacent carriageway surfacing. This is to act as a dam to retain the surfacing and to isolate the surfacing from any tensile forces imposed on the deck by the joint system.

4.7.4 continued

d. Asphaltic plug (elastomeric concrete) joints

Asphaltic plug joints are in-situ joints comprising a band of specially formulated flexible material, commonly consisting of rubberised bitumen with aggregate fillers. The joint is supported over the gap by thin metal plates or other suitable components.

Except in retrofit applications where the existing structural configuration prevents these joint dimensional requirements being met, elastomeric concrete plug joints shall be designed and specified to have a minimum thickness of 75mm and a minimum width of bond with the structure on either side of the joint gap of 200mm. Such joints shall be designed by the supplier or the supplier's agent to take account of the predicted movements at the joint including rotation of the ends of the bridge decks to be joined due to traffic loads.

Where proposed for use in retrofit situations with dimensions less than those specified above, evidence shall be supplied to the road controlling authority of satisfactory performance of the joint system under similar or more demanding traffic conditions with a similar joint configuration over periods of not less than 5 years.

4.8 Integral and semi-integral abutments

4.8.1 Definitions

- a. An integral abutment is defined as one that is built integrally with the end of the bridge superstructure and with the supporting piles or footing. The abutment therefore forms the end diaphragm of the superstructure and the retaining wall for the approach filling. The supporting piles are restrained against rotation relative to the superstructure, but are free to conform to superstructure length changes by pile flexure.
- b. A semi-integral abutment is defined as an integral abutment that contains provision for relative rotation, but no more than limited translation, between the superstructure and the supporting piles or footing.

4.8.2 Design criteria

Integral and semi-integral abutments are acceptable for bridges that meet the following criteria:

- a. Length between the rear faces of abutments not exceeding:
 - with concrete superstructure 70m
 - with steel superstructure main members 55m

These values may be doubled for a length of superstructure that contains an intermediate temperature movement deck joint.

- b. The abutment piles and surrounding soil shall possess adequate flexibility to enable superstructure length changes to occur without structural distress.
- c. An approach settlement slab complying with 4.12.2 shall be attached to the back face of the abutment.

Integral and semi-integral abutments are acceptable for longer bridges provided rational analysis is applied to evaluate the effect of the superstructure length change on the supporting piles. Adequate measures shall also be taken to ensure the bridge approach remains serviceable.

4.8.2 continued

In addition to withstanding the normal design loading combinations, bridges with integral or semi-integral abutments shall be designed to avoid collapse of the bridge under the maximum considered earthquake event (MCE) as defined in sections 5 and 6. This may require that the bridge abutments and superstructure be designed to withstand the maximum passive pressure capacity able to be mobilised by the soil to act on the abutments.

The NZTA research report 577 *Criteria and guidance for the design of integral bridges in New Zealand*⁽⁵⁶⁾ provides guidance further to this clause on the design of integral bridges in New Zealand.

4.8.3 Application of BA 42⁽⁵⁷⁾

The design of integral abutments for resistance to longitudinal thermal movements and braking loads shall comply generally with the UK Design Manual for Roads and Bridges document BA 42 *The design of integral bridges*⁽⁵⁷⁾ as outlined below. For seismic loading and other loadings outside the scope of BA 42⁽⁵⁷⁾ reference should be made to alternative literature, such as:

- NZTA research report 577⁽⁵⁶⁾
- *Recommended LRFD guidelines for the seismic design of highway bridges*⁽⁵⁸⁾
- *Backbone curves for passive lateral response of walls with homogenous backfills*⁽⁵⁹⁾.

The general design requirements given in sections 1 and 2 of BA 42⁽⁵⁷⁾ should be adopted for bridges with integral abutments. Earth pressures on integral abutment walls arising from temperature movements shall be calculated using the provisions of section 3 of BA 42⁽⁵⁷⁾.

The following notes provide information on the design parameters used in BA 42⁽⁵⁷⁾ but not adequately defined and the changes required to BA 42⁽⁵⁷⁾ to make it consistent with the provisions of the *Bridge manual*. The applicability of the various documents referenced in BA 42⁽⁵⁷⁾ and cross-references to relevant provisions of the *Bridge manual* are also noted.

a. Sections 1.1, 2.4 and 2.15

BD 57 *Design for durability*⁽⁶⁰⁾ provides design requirements, and BA 57 *Design for durability*⁽⁶¹⁾ design advice on design for durability and information on various methods of achieving continuity between spans to eliminate deck joints, which may lead to a more durable design. Not all of the requirements or advice however is appropriate to New Zealand conditions. Design for durability shall comply with this manual and its supporting materials design standards which set out the requirements for durability design of materials and of various structural elements.

b. Section 1.4

BD 30 *Backfilled retaining walls and bridge abutments*⁽⁶²⁾ provides design requirements on backfilled retaining walls and abutments and may be used in conjunction with BA 42⁽⁵⁷⁾.

c. Section 1.5

BD 31 *The design of buried concrete box and portal frame structures*⁽⁶³⁾ provides design requirements on buried concrete box structures and may be used in conjunction with BA 42⁽⁵⁷⁾.

4.8.3 continued

d. Section 2.5

The limit of ± 20 mm is for thermally induced cyclic movements and is not intended to include creep, shrinkage or earthquake load induced movements. This limit may be exceeded subject to a rational analysis as outlined in 4.8.2 of this manual.

e. Section 2.6

Temperature difference, shrinkage and creep effects are covered in 3.4.4 and 3.4.6 of this manual and should be used instead of the loads given in the referenced documents (ie BD 24 *The design of concrete highway bridges and structures. Use of BS 5400: Part 4: 1990*⁽⁶⁴⁾ and BD 37 *Loads for highway bridges*⁽⁶⁵⁾).

f. Section 2.7

The load factors specified in 3.5 of this manual shall be used instead of the factors specified in BD 37⁽⁶⁵⁾.

g. Section 2.8

The load factors for passive pressure forces shall be as specified in 3.5 of this manual.

h. Section 2.9

The soil material strength reduction factors given in 6.5.3 of this manual shall be used instead of the material partial safety factors specified in this section.

i. Section 2.10

The characteristic thermal strains given in this section are not consistent with the provisions of this manual. They shall be calculated using the temperature differences given in 3.4.6 of this manual. For the purpose of estimating temperature induced pressures on the abutment walls the load factor applied to thermal strains shall be taken as 1.0.

j. Section 2.11

New Zealand mean temperatures can be found from NIWA's *New Zealand mean annual temperature (°C), 1971 - 2000*⁽⁶⁶⁾.

k. Section 2.16

In place of reference to BD 24⁽⁶⁴⁾, reference shall be made to NZS 3101⁽¹⁾ for serviceability requirements under design live loading.

l. Section 3.3

In BS 8002 *Code of practice for earth retaining structures*⁽⁶⁷⁾ the soil design strength is defined as; "Soil strengths which are assumed will be mobilized at the occurrence of a limit state. The design value of soil strength is the lower of either the peak soil strength reduced by a mobilization factor or the critical state strength." Clause 3.1.8 of BS 8002⁽⁶⁷⁾ states: "Single design values of soil strength should be obtained from consideration of the representative values for peak and ultimate strength. The value so selected will satisfy simultaneously the considerations of ultimate and serviceability limit states. The design value should be the lower of:

- i. That value of soil strength, on the stress-strain relation leading to peak strength, which is mobilized at soil strains acceptable for serviceability. This can be expressed as the peak strength reduced by a mobilization factor M as given in 3.2.4 or 3.2.5; or
- ii. That value which would be mobilized at collapse, after significant ground movements. This can generally be taken to be the critical state strength."

4.8.3 continued

m. Section 3.4

For determining wall pressures arising from thermal expansion, values of K_p should be based on design ϕ' and $\delta = \text{design } \phi'/2$. K_p can be taken from the chart shown in figure 4.2 which has been adapted from BS EN 1997-1 *Eurocode 7. Geotechnical design part 1 General rules*⁽⁶⁸⁾ by adding a curve for $\delta/\phi' = 0.5$.

In combining load effects, as specified in 3.5, the pressure due to thermal expansion shall be treated as a temperature load (TP).

n. Section 3.5.1

For wall heights up to 3m, K^* should be assumed to act uniformly over the height of the abutment wall.

o. Sections 3.8, 3.9, and 3.15

Selected free draining granular backfill should be used within a distance behind the wall equivalent to twice the height of the abutment wall. The material should be carefully selected to allow displacement of the abutment wall under thermal expansion of the bridge. This may require any in situ rock or very stiff materials to be excavated and replaced with fill materials to accommodate such movements. The material should be compacted using hand compaction methods to avoid damage to the structure, minimise compaction pressures and displacement during the compaction process. Large compaction plant shall not be used. The compaction shall achieve a minimum of 95% of the maximum dry density, and comply with the requirements of NZTA specification TNZ F/01 *Earthworks construction*⁽⁶⁹⁾. In addition, a drainage layer and sub-soil drain (NZTA specifications NZTA F2 *Pipe subsoil drain construction*⁽⁷⁰⁾ or TNZ F/06 *Fabric wrapped aggregate subsoil drain construction*⁽⁷¹⁾) should be incorporated behind the wall to avoid groundwater pressures on the wall.

Figure 4.2: Coefficient of passive earth pressure (horizontal component) for vertical wall and horizontal backfill

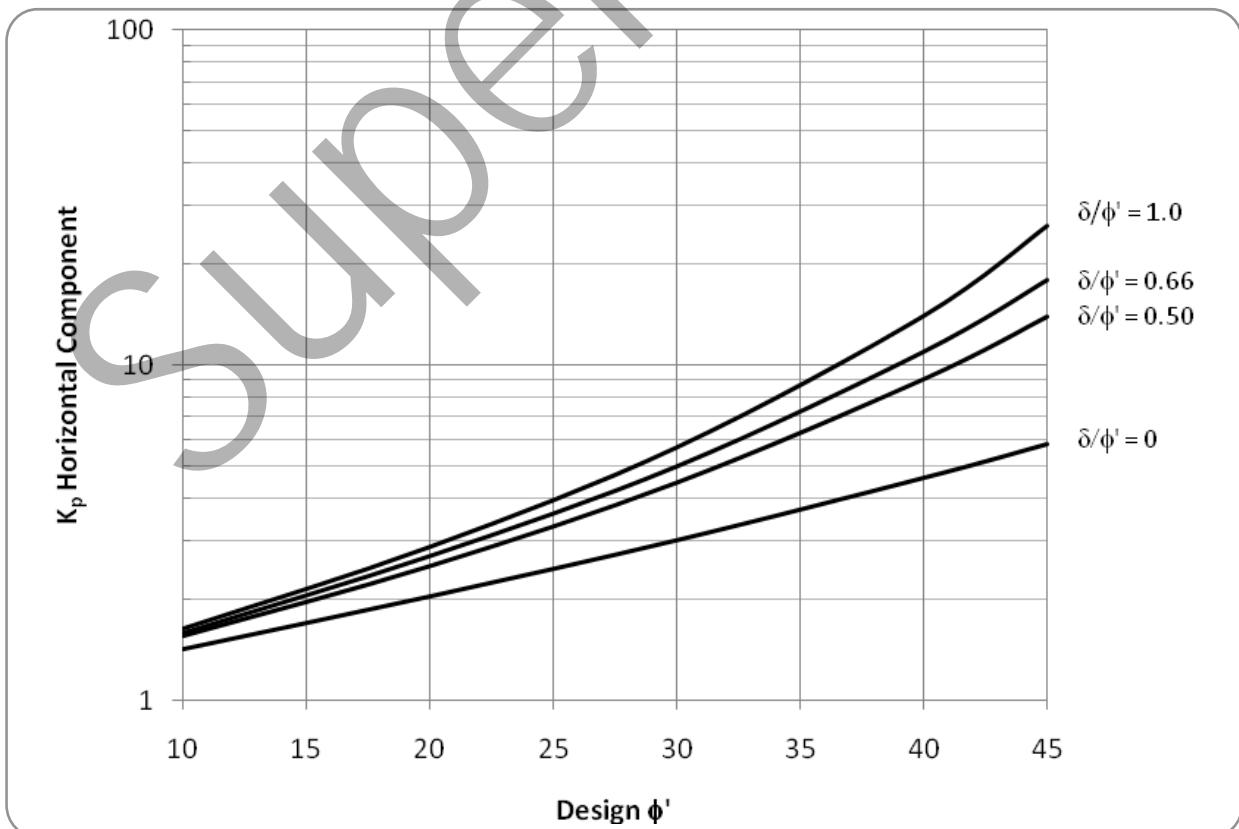

4.9 Network and tied arch bridges – hanger supports

Hangers supporting the bridge deck from the main arch ribs shall be protected from vehicle collision by a barrier system of minimum performance level 5.

The design of each hanger and associated structure shall consider the following three scenarios and associated design requirements:

a. Scenario 1: Failure of a single hanger due to fatigue

Design load case: $1.20DL + 1.20SDL + 1.20(LL \times I) +$ hanger loss dynamic forces

Where:

DL = dead load of structural components and non-structural attachments

SDL = superimposed dead loads as specified in 3.4.2

LL = HN (normal) traffic live load placed in their actual marked lanes, using lane factors in accordance with 3.2.4(a)

I = dynamic load factor

The hanger loss dynamic forces shall be taken as twice the static force in the hanger unless demonstrated by a suitable time history analysis that a lesser hanger loss dynamic force is appropriate. The hanger loss dynamic force shall not be taken to be less than 1.5 times the static force in the hanger.

b. Scenario 2: Continued bridge operation while a hanger is repaired

Design load case: $1.35DL + 1.35SDL + 1.5(LL \times I) + FP +$ hanger exchange forces

Where:

DL = dead load of structural components and non-structural attachments

SDL = superimposed dead loads as specified in 3.4.2

LL = HN (normal) traffic live load placed in their actual marked lanes, using lane factors in accordance with 3.2.4(a)

I = dynamic load factor

FP = pedestrian and cycle track loading

Hanger exchange forces include the redistribution of loads through the structure as a result of the missing hanger and/or replacement of the missing hanger when it is repaired.

The above load combination is to be considered with the traffic live load placed in their marked lanes with each hanger in turn, one at a time, missing to evaluate the bridge under an 'unnoticed lost hanger' scenario.

c. Scenario 3: Hanger failure due to collision

Within a single plane of hangers, all hangers within any 4.0m length taken at the level of the bottom chord, but not less than two hangers, adjacent to or crossing each other, shall be considered to break, one after the other, sequentially.

Design Load Case: $1.20DL + 1.20SDL + 1.0(LL \times I)$

4.9 continued

Where:

DL = dead load of structural components and non-structural attachments

SDL = superimposed dead loads as specified in 3.4.2

LL = traffic live load taken as one 36 tonne vehicle positioned as described below

I = dynamic load factor

The traffic live load shall be distributed longitudinally along the bridge over a 12m length positioned symmetrically about the group of breaking hangers. (Eg in the case of there being only two hangers crossing each other that break, the live load shall be distributed symmetrically either side of the point where the hangers cross.) The vehicle shall be taken to be 2.5m wide positioned on the carriageway against the traffic barrier adjacent to the breaking hangers.

Loads and conditions shall be applied to the arch span as follows:

- One hanger shall be removed from the structural model (considered to have failed ahead of the second hanger).
- At the second hanger to fail position, the hanger shall be removed from the structural model and inward forces applied to the arch rib and bottom tension chord in the line of the hanger equal to $1.2F_{pu} - F$.

Where:

F_{pu} = characteristic failure load of the hanger

F = load in the hanger before failure under $1.20DL + 1.20SDL + 1.0(LL \times I)$

Inward forces means: When applied to the arch rib, the force is acting in the direction towards the bottom tension chord, and when applied to the bottom tension chord, the force is acting in the direction towards the arch rib.

- The arch shall remain stable. Yielding is to be avoided in the arch rib and in all elements that could lead to instability or that are not easily repaired.
- The effect of the hangers potentially being deflected out of the plane of the arch at the time when they break, imposing lateral loading on the arch, shall be considered. The level at which the cable is struck shall be taken as anywhere between the top of the barrier and 4.3m above deck level.
- Also the effects of the hanger being deflected sideways in a collision on end connections of the hanger to the arch rib and bottom tension chord are to be considered. Hanger connections are to be detailed to allow for their easy repair and hanger replacement throughout the design life of the bridge.

4.10 Buried structures

4.10.1 General

The design and construction of corrugated metal structures shall comply with AS/NZS 2041 *Buried corrugated metal structures*⁽⁷²⁾ (the most relevant and up-to-date version or part thereof) except as modified or superseded herein.

The design of concrete box culvert structures shall comply with NZS 3101⁽¹⁾.

The design of precast concrete pipes shall comply with AS/NZS 3725 *Design for installation of buried concrete pipes*⁽⁷³⁾ and AS/NZS 4058 *Precast concrete pipes (pressure and non-pressure)*⁽⁷⁴⁾ except as modified or superseded herein.

The design requirements set out below shall supersede those included in the AS or NZS standards for defining loads and the load application to the buried structure. The requirements of the respective AS and NZS standards shall be used for determining the internal forces and actions for the buried structure and for determining the appropriate acceptance criteria, except as otherwise amended.

The design and detailing of buried structures shall be such that the design working life is achieved without reconstruction or major rehabilitation within that period (except as outlined below). Sufficient investigation shall be undertaken to ensure the aggressiveness of the site (corrosion, abrasion and chemical attack) is appropriately evaluated and the structure designed for durability accordingly.

For sites where the buried structure is under large fill heights or in a location where future replacement or rehabilitation may be very expensive, longer service life options or options including specific provision for future rehabilitation (eg installing an oversize pipe to allow for future sleeving) shall be considered.

Design of corrugated steel structures shall be on the basis of one of the following approaches:

- a. For a design working life of 100 years with, in addition to the initial galvanizing, sacrificial wall thickness provided to compensate for the loss of section due to corrosion, or a supplementary corrosion protection system provided, capable of enabling the structure to achieve the specified durability.
- b. For a design working life of 50 years, but oversized sufficiently to enable sleeving at the end of its life with a smaller sized barrel satisfying the waterway requirements of this manual. The adoption of this option shall be based on a comparison of the 'whole of life' costs over a 100-year period of this option, including the cost of sleeving, with the cost of option (a). Use of this option shall be subject to the approval of the road controlling authority.

Where a steel invert is provided and significant abrasion over the life of the structure is anticipated, a concrete invert shall be installed at initial construction, unless agreed otherwise with the road controlling authority. The concrete invert shall be suitably detailed, reinforced and tied to the culvert floor and the base of the walls up to 300mm above the normal water flow surface. The upstands against the culvert walls shall have their top surfaces sloped inwards so that water does not pond against the galvanizing. Placement of the concrete lining should ideally be delayed for six months or more following construction of the culvert to allow initial flexing and settlement of the structure to cease.

4.10.1 continued

Clause 2.8.2.1 of AS/NZS 2041.2⁽⁷²⁾ shall be modified by adding the following to the end of the first paragraph:

- Each uncoated area for renovation shall not exceed 1000mm². If uncoated areas are larger, the article containing such areas shall be regalvanized unless agreed otherwise between the road controlling authority and the galvanizer.

Pipe and corrugated metal culverts shall be provided with not less than 600mm of cover and where possible all other culverts, pedestrian/cycle subways and stock underpasses shall be provided with the same cover. Where the cover is to be less than 600mm, an alternative pavement design should be provided and measures taken to reduce reflected pavement cracking and differential settlement at the road surface to acceptable levels, including the provision of settlement slabs (see 4.12.2) unless they are agreed with the road controlling authority to not be necessary. Additional cover shall be provided where necessary to accommodate existing utility services, future services where there is a policy or agreement to do so and existing or planned longitudinal stormwater drainage.

In determining the size and shape of the buried structures appropriate consideration shall be given to fish passage, climate change, and inspection and maintenance requirements. Design shall consider the effects of vibration, settlement, batter stability, piping/erosion and possible earthquake induced ground deformation or liquefaction on the structure.

The Austroads *Guidelines for design, construction, monitoring and rehabilitation of buried corrugated metal structures*⁽⁷⁵⁾ provides useful guidance.

4.10.2 Rigid buried structures

Rigid buried structures include concrete box, concrete arch and precast concrete pipe. Precast concrete pipes used on state highways shall be steel reinforced.

Design live loadings and their application shall be as follows:

- The full range of load case and combinations as specified in section 3 shall be evaluated and met at both the serviceability and ultimate limit states.
- The HN and HO load footprints applied to the pavement shall be as specified in section 3. The load spread through the fill above the buried structure shall use the AS 5100.2⁽³⁰⁾ section 7.12 'double trapezoidal prism' consisting of 0.5:1 load spread in the top 0.2m and 1.2:1 load spread through the remaining cover depth when the cover depth equals or exceeds 0.4m. The 3.5kPa traffic load UDL shall be applied with no load spread. The dynamic load factor shall be applied as set out in 3.2.5.
- When the cover depth is less than 0.4m the HN and HO footprints shall be applied directly to the top surface of the buried structure, in conjunction with the 3.5kPa UDL, to generate the worst internal action effect. The dynamic load factor appropriate to the least design cover depth shall be applied as set out in 3.2.5.
- Rigid buried structure design shall include the 1.35HN serviceability limit state combination.
- For precast concrete pipes, for the situation under consideration, the class of pipe required shall be derived from AS/NZS 4058⁽⁷⁴⁾ based on the required proof load capacity determined in accordance with AS/NZS 3725⁽⁷³⁾.

4.10.3 Semi-rigid and flexible buried structures

Semi-rigid and flexible buried structures include corrugated metal structures. Design live loadings and their application shall be as follows:

- The full range of load case and combinations as specified in section 3 shall be evaluated and met.

4.10.3 continued

- Unless a soil - structure interaction analysis (which takes structure stiffness, foundation stiffness and the type, compaction and drainage of the backfill into account) is undertaken then the HN-HO-72 live load pressure to be applied to the crown of the buried structure shall be determined as follows:

$$P_v = 1.35(32H^{-1.852} + 3.5)$$

Where:

P_v = vertical pressure in kPa on the plan projected area of the structure due to HN-HO-72 live loads including dynamic load effects and the serviceability load factor of 1.35 on live load.

H = minimum depth of cover in m measured from the trafficked surface level to the crown of the pipe

This equation is appropriate for cover depths greater than or equal to 0.6m and includes HN, HO and dynamic load factor effects. For the purpose of serviceability limit state design it is appropriate to assume that the 1.35HN traffic pressure governs for cover depths less than 0.9m using load combination 1A from table 3.1 or 3.2 and HO traffic pressure governs for cover depths equal to or greater than 0.9m using load combination 4 from table 3.1 or 3.2. For the ultimate limit state load combination 1A (table 3.2) the traffic pressure determined from the above formula shall be divided by 1.35 to determine the basic HN traffic load pressure before applying the specified ultimate limit state load factor of 2.25 to the HN load.

- Unless the depth of cover to the structure equals or exceeds the diameter or span of the structure no load reduction shall be made for soil arching effects.

4.10.4 Earthquake loading on buried structures

The earthquake response of underground structures shall be considered with reference to the three principal types of deformations: axial, curvature and racking (rectangular cross-sections), or ovaling (circular cross-sections). Axial and curvature deformations develop when seismic waves propagate either parallel or obliquely to the longitudinal axis of the structure (figure 4.3). The general behaviour of a long structure subjected to a component of parallel wave deformation is similar to that of an elastic beam embedded in the soil. In simplified analyses, the structure is assumed to be flexible relative to the surrounding soil or rock, and to respond with the same deformation pattern as in the free-field elastic seismic waves. These simplified analyses are often employed for pipelines that have relatively small cross-sectional areas and for the preliminary analyses of tunnels and culverts. When the structure is stiff in the longitudinal direction relative to the surrounding soil, it will not be compliant with the soil or rock deformations. For this case, interaction effects need to be considered by employing either numerical methods or approximate solutions developed from wave propagation theory for beams on an elastic foundation (see *Seismic design of tunnels*⁽⁷⁶⁾).

Figure 4.3: Axial and curvature deformations (from FHWA-NHI-11-032⁽⁷⁷⁾)

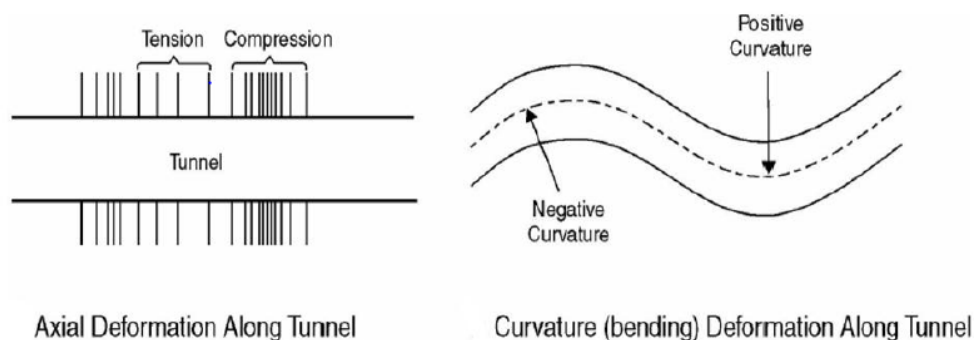

4.10.4 continued

Ovaling or racking deformations develop in an underground structure when the seismic waves propagate in a direction perpendicular to, or with a significant component perpendicular to, the longitudinal axis, resulting in distortion of the cross-section (see figure 4.4). For this case, and if the structure is relatively long, a plane-strain two-dimensional analysis is usually employed.

Figure 4.4: Axial and curvature deformations (from FHWA-NHI-11-032⁽⁷⁷⁾)

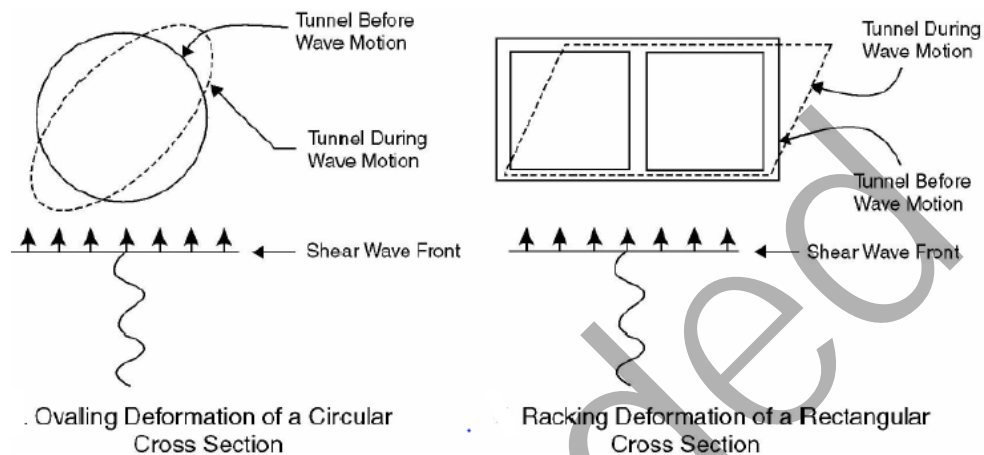

The racking performance of the cross-section of an underground structure subjected to earthquake ground motions can be undertaken using the following steps:

- evaluation of the free-field peak shear strain in the soil at the average depth of the structure
- evaluation of the elastic and post-elastic stiffness of the structure
- evaluation of the racking deformation of the structure from the free-field strain, structure stiffness and soil-structure interaction curves
- evaluation of the member forces in the structure from the racking deformation.

The shear distortion of the ground from vertically propagating shear waves is usually considered to be the most critical and predominant effect producing racking type deformations in underground structures. Numerical methods are often applied to estimate the free-field shear distortions, particularly in sites with variable stratigraphy. Computer codes such as SHAKE based on one-dimensional wave propagation theory for equivalent linear systems can be used to carry out these types of analyses.

An alternative to undertaking numerical analyses to predict free-field shear deformations is to use theory of elasticity analytical solutions for vertically propagating shear waves in a layer of uniform thickness. These solutions provide sufficiently good approximations for the design of smaller underground structures, particularly where the site soil properties are not known in any detail. They are useful for preliminary analysis work and provide a verification method for more sophisticated numerical analysis. Analytical solutions are presented in *Earthquake design of rectangular underground structures*⁽⁷⁸⁾.

Because of both soil-structure interaction and dynamic inertial effects, the soil shear strains near the structure are generally significantly different to the free-field shear strain at the corresponding depth in the soil layer. Often the mass change at the cavity created by the structure is small in relation to the total mass in the layer acting in unison with the structure and dynamic inertial effects are sufficiently small to be neglected.

4.10.4 continued

In contrast to the influence of soil inertial effects, soil-structure interaction effects may produce significant changes in the shear strains near the structure. If a cavity in the soil is unlined or lined with a very flexible structure, the shear strains may be greater than in the free-field. If a stiff structure is inserted in the soil cavity, then the shear strains may be less than the free-field.

In assessing soil-structure interaction effects on underground structures it is usual to define shear strain deformation and flexibility ratios. The shear strain deformation ratio (R) is defined by:

$$R = \frac{\textit{Shear deformation of structure embedded in soil (including Interaction)}}{\textit{Free – field shear deformation over height of structure}}$$

The flexibility ratio (F_r) is defined by:

$$F_r = \frac{\textit{Shear flexibility of free standing structure without soil interaction}}{\textit{Shear flexibility of soil block of same overall dimensions of the structure}}$$

The flexibility ratio (F_r) can be readily computed from the soil shear modulus (G) and the structure flexibility. Methods for calculating the shear deformation ratio (R) from the flexibility ratio have been presented for both circular and rectangular sections in *Seismic design of tunnels*⁽⁷⁶⁾, *Seismically induced racking of tunnel linings*⁽⁷⁹⁾, *A simplified evaluation method for the seismic performance of underground common utility boxes*⁽⁸⁰⁾, *Earthquake design procedures for rectangular underground structures*⁽⁸¹⁾ and *Earthquake design of rectangular underground structures*⁽⁷⁸⁾. The structure shear deformation including soil-structure interaction can be calculated from the shear deformation ratio (R) and estimates of the peak free-field shear deformation during the design earthquake event. The structure shear deformation is then used to calculate the earthquake-induced stresses in the members of the structure using analytical or numerical methods (Wang, 1993 and Wood, 2005).

Alternatively, finite element analyses based on the estimated free-field shear deformation can be used to calculate the earthquake induced stresses in the structure. If these more complex analyses are undertaken the four-step procedure using the F_r ratio can be used to check the results.

4.10.5 Backfilling around buried structures

Guidance on the selection of fill materials, method of placement and compaction of backfill for culverts can be found in AS/NZS 2041.2⁽⁷²⁾, sections 2.4 and 2.12. The following provides further clarifications to those requirements.

The tests below have been prescribed in NZS 4402 *Methods of testing soils for civil engineering purposes – Soil tests*⁽⁸²⁾ for the purposes of evaluating soil compaction:

- NZS 4402.4.1.1 *New Zealand standard compaction test*⁽⁸³⁾
- NZS 4402.4.1.2 *New Zealand heavy compaction test*⁽⁸⁴⁾
- NZS 4402.4.1.3 *New Zealand vibrating hammer compaction test*⁽⁸⁵⁾
- Section 4.2 *Determination of the minimum and maximum dry densities and relative density of a cohesionless soil*, which includes the following laboratory tests:
 - NZS 4402.4.2.1 *Minimum dry density*⁽⁸⁶⁾
 - NZS 4402.4.2.2 *Maximum dry density*⁽⁸⁷⁾

4.10.5 continued

Clause 2.12.5 of AS/NZS 2041.2⁽⁷²⁾ allows compaction level acceptance criteria to be based on test results from any of the above tests. The choice on which of these tests should be used shall be based on how closely the test procedures prescribed in the standards simulate the workings of the compaction equipment used in the field. If the use of heavy and vibratory compaction equipment is not required, the maximum dry density (MDD) from the NZ standard compaction test (NZS 4402.4.1.1:1986) will be appropriate and the dry density in each layer of fill (in accordance with clause 2.12.4.2 of AS/NZS 2041.2⁽⁷²⁾) shall be compacted to at least 95% of the MDD.

Relative density from NZS 4402.4.2.1:1988 and NZS 4402.4.2.2:1988 should only be used as a compaction acceptance criteria if the select fill contains less than 12% by mass of non-plastic fines passing a 0.075mm sieve and there is a stringent need to minimise compression in the backfill, in which case an indication of the highest possible value of dry density for the backfill would be required. For these cases each layer of select fill shall be compacted to not less than 70% of the relative density. As noted in the standards, laboratory results from NZS 4402.4.2.2:1988 are highly sensitive to the capability of the vibratory table used in the test, and strict adherence to the mechanical specifications given in NZS 4402.4.2.2:1986 for the vibratory table is necessary for the compaction test results to be repeatable.

4.11 Bridges subject to inundation by flooding

Where it is proposed to place a bridge over a waterway, care should be taken to so locate it that immersion will not be likely to occur. In cases where immersion is unavoidable or cannot readily be designed for, then it may be appropriate to consider other forms of construction in preference to prestressed concrete, which is particularly vulnerable to the effects of immersion.

When a bridge is covered by floodwaters the upthrust on the structure exerted by the water cancels out some of the dead load acting downwards. In prestressed concrete bridges the upthrust of the water combines with the upthrust due to draped or eccentric prestressing tendons and this may lead to unfavourable stress distribution in the beams; especially so if air is entrapped between the girders, so increasing the volume of water displaced.

In all cases where waterway crossings are to be constructed, careful consideration shall be given to stresses induced under submerged conditions. Ducts should be formed through the girder webs as close to the underside of the deck slab as possible, preferably by means of a short length of pipe which can be left in place so as to offset the loss of section. These ducts should be placed in positions that will be most effective to releasing entrapped air, giving considerations to the grades, vertical curves and crossfalls to which the bridge may be constructed.

In the case of composite construction, where a cast in-situ deck is poured onto prestressed concrete or steel beams, sufficient steel must be incorporated across the interface between the beams and the deck slab to resist the tendency of the deck to separate from the beams under the uplift forces acting under submergence; and to place the air escape ducts as high up as possible to reduce this tendency.

4.12 Miscellaneous design requirements

4.12.1 Proprietary items

Wherever proprietary items are required as part of the structure, allowance shall be made as far as possible for any brand to be used. Brand names shall not be quoted in the documents unless it is essential to the design that a particular brand is used.

4.12.2 Settlement slabs

A settlement slab shall be provided at every bridge abutment unless they are agreed with the road controlling authority to not be necessary. Examples where a settlement slab may not be necessary are abutments with no earth filling or low volume or low speed environments. Settlement slabs shall be provided for buried structures (ie culverts, stock underpasses and pedestrian/cycle subways) as detailed in 4.10.1. Settlement slabs shall extend over the full width of expressway carriageways (ie the width of traffic lanes plus shoulders) but may be omitted over the width of medians.

The slab shall be simply supported along one edge by the abutment, and shall be designed for dead and live load, assuming that it spans at least three-quarters of its actual length, in the longitudinal direction of the bridge or road. Slabs shall be at least 2m in length and sloped to divert surface water from flowing down the abutment/soil interface. For bridges longer than 30 m the slab shall be at least 3m in length. The slab shall be a minimum of 600mm below the road surface. The effects set out in 2.5 shall be considered. In addition to being supported at one edge by the structure, the settlement slabs shall also be tied longitudinally to the structure to prevent them being pulled off their seating through the actions of settlement beneath them or by earthquake actions. The design yield strength of the connection of the slab to the structure, factored by the strength reduction factors given in NZS 3101⁽¹⁾, shall be at least 1.3 times the nominal sliding resistance of the settlement slab.

Settlement slabs, in addition to catering for settlements behind abutments arising from normal service conditions, shall accommodate settlements that may arise from earthquake actions the magnitude of which may be large and unexpected. Settlement slabs shall be detailed to be able to accommodate at least 500mm of settlement behind the abutments over their length.

4.12.3 Deck drainage

In general, stormwater shall be collected and specific provision made for its disposal. On bridges that are waterway crossings stormwater may be discharged over the edge of the deck unless prohibited by the resource consent.

Deck drainage shall be designed to the standards adopted for the highway drainage system. In particular, the outlet pipes and pipe system shall be designed for a rainfall event with a return period of not less than 20 years including the effects of predicted climate change. Guidance on the design for surface drainage may be obtained from *Highway surface drainage: Design guide for highways with a positive collection system*⁽⁸⁸⁾, except that more up-to-date sources of information to that referenced should be drawn on for the estimation of design storm rainfall. These sources include:

- local rainfall databases, as may be held by the regional council responsible for the locality under consideration
- *High intensity rainfall design system (HIRDS) version 3*⁽⁸⁹⁾, a web based program for estimating rainfall frequency
- *Climate change effects and impacts assessment: A guidance manual for local government in New Zealand - 2nd edition*⁽⁹⁰⁾
- *The frequency of high intensity rainfalls in New Zealand, part 1*⁽⁹¹⁾.

4.12.3 continued

The deck drainage of bridges, and of other structures if directly carrying traffic, shall be designed to ensure that any ponding in any part of any traffic lane is limited to a maximum depth of 4mm of sheet flow above any surface texture during a two year return period rainfall.

To avoid pipes silting up from deposits left by slow flowing water pipes shall be laid on as steep a grade as practicable and not less than the figures below for the listed diameters:

Diameter (mm)	150	225	300	375
Grade (%)	1.0	0.5	0.35	0.25

The visual impact of drainage pipework shall be minimised. Ducting or pipework shall not run along external faces of structures or vertically down pier or abutment faces that are visible to the public. Longitudinal deck drainage collection pipes on bridges shall not be located on the outside of or below the outside beams. Feeder pipes from catch pits may be visible, but shall be concealed as far as possible. Deck drainage shall not be carried in steel pipework. Pipework carried in hollow members shall also comply with the relevant requirements of 4.12.5.

Pipework shall be supported by a support system. The support system and its spacing shall ensure that no appreciable sag occurs to the pipe under the design load for the pipe full case.

Pipework shall incorporate movement joints or other mechanisms to allow for the serviceability limit state design movements of the bridge calculated for load combinations 2A and 2B given in table 3.1. The relative movement between parts of the structure under one quarter of the earthquake relative movement plus the relative movement due to long term shortening plus one third of the temperature induced relative movement from the median temperature position shall also be provided for.

Drainage pipe material shall comply with NZTA F3 *Specification for pipe culvert construction*⁽⁹²⁾.

All components of the drainage system shall have a life to first maintenance of not less than 30 years. The drainage system shall be replaceable without modification or removal of any structural concrete or steelwork. This does not however preclude casting pipework into concrete piers.

All components of the bridge deck drainage systems shall be designed to be self-cleansing, and shall be detailed to allow adequate access for future inspection, maintenance and cleaning. A minimum collector pipe internal diameter of 150mm shall be provided. All drains shall be capable of being cleared of blockages under routine maintenance activities without the need for closure of carriageways beneath the structure. Manholes, if required, shall not be located within the road carriageways.

The deck drainage system shall be detailed to ensure water does not leak onto visible surfaces, causing staining or corrosion, or onto bearings or energy dissipating devices. Positive fall drainage shall be provided on all bearing shelves, under expansion joints and behind all earth retaining abutments and walls. Drip grooves shall be provided at the edge of all slab soffits. Deck movement joints shall be made watertight.

Sumps in the bridge deck shall be positioned and detailed in a manner that will ensure traffic ride is not affected and that will provide for future resurfacing of the bridge deck.

4.12.4 Drainage of hollow structural elements

If hollow structural components are adopted, then positive fall drain holes of 40mm minimum diameter shall be provided at all low points within the voids regardless of their susceptibility to ponding. In the case of bridge superstructure slab or beam elements, drain holes shall be provided in each void and shall discharge directly to the outside through the soffit of the element. All such drain holes shall be accessible for maintenance.

4.12.5 Services

Agreement shall be reached with network utility operators of services, over support conditions required for services and minimum spacing requirements between different services. Network utility operators shall be made aware of the extent and direction of movement at expansion joints, due both to length changes and seismic acceleration. Where a lesser standard of design for earthquake resistance has been accepted by the road controlling authority than that specified by this manual (eg due to the high cost of mitigating liquefaction effects), network utility operators whose services are proposed to be carried on the structure shall be advised of the design standard accepted to be adopted for the structure and shall be responsible for ensuring that appropriate measures are adopted to achieve continuity of operation of their services following a major earthquake event.

The implications of possible bridge overloading due to leakage or rupture of pipes carrying water or other fluids inside a box girder or other hollow member shall be considered, and adequate drainage shall be provided.

Special approvals and conditions apply to the installation of pipelines carrying flammable fluids (including gas). Such pipelines shall not be carried inside box girders.

Regulations requiring minimum spacing between different types of services (eg as may apply between water supply and sanitary sewer; and between gas and electricity) shall be complied with. The final location of ducts shall be discussed and agreed with utility operators.

Services carried on a bridge deck or trafficked deck of a buried structure shall be adequately protected against possible loading by vehicle wheels, horses and stock.

Unless otherwise directed by the road controlling authority, on new bridges with either hollow core unit superstructures or raised footpaths, in addition to the known services and where practical to do so, a nominal provision shall be made for future services to be carried by the installation or casting into these elements of 2 × 150mm diameter uPVC ducts with durable draw wires installed. These ducts shall be located within the width of the footpath or the outermost available voids for hollow core decks unless alternative locations are directed or accepted. All unused ducts shall be provided with water-tight terminations located outside of the sealed carriageway.

4.12.6 Date and loading panels

All structures subjected to direct traffic loading shall have displayed details of the date of construction and design live loading.

Each structure designed to HN-HO-72 loading shall have this information displayed on two panels, as shown in figure 4.5. The panels shall be of bronze or other approved material of equivalent durability.

The panels shall be located one at each end of the structure on the left hand side of approaching traffic and in a conspicuous location, eg on the top surface of footpaths or safety kerbs, on the carriageway face of concrete barriers, or on the deck behind the line of the guardrail clear of any subsequent sealing work.

Structures designed to other loadings shall have similar panels.

4.12.7 Load limiting devices and shock load force transfer devices

a. Abutment knock-off elements and deck slab knock-up elements

Abutment 'knock-off' elements and deck slab 'knock-up' elements, at deck joints, designed to be displaced under response of the bridge to strong earthquakes, thereby allowing freedom of movement of the bridge superstructure without significant interaction with adjacent structure, shall be:

- stable under traffic loads at the ultimate limit state
- able to resist the forces imposed on the knock-off or knock-up element by an attached deck joint at the ultimate limit state displacements under service conditions that exclude earthquake effects
- able to be dislodged without significant damage to adjacent structural elements. Abutment knock-off elements are not to be dowelled to the abutment back wall.

b. Earthquake energy dissipating devices

Devices for dissipating earthquake energy, that also act to limit the earthquake forces mobilised within the structure, shall comply with 5.6.14 and shall also ensure that 5.1.2 (c) will be satisfied.

c. Shock load force transfer devices

Devices designed to accommodate slow rates of movement between adjacent structural elements interconnected by the device without significant transfer of force due to the movement, but designed to lock-up and provide force transfer under shock loading from an earthquake, shall be designed with sufficient ideal strength to resist the forces imposed on them. The forces imposed on the devices shall be assessed from a rational analysis of the structure assuming overstrength to have developed in plastically yielding elements of the structure.

4.12.8 Confinement of embedded fixings

Embedded fixings forming part of the primary load path for transferring forces into the structure (eg side protection barrier fixings) or transferring forces from the superstructure to the substructure (eg bearing and base isolation system fixings, holding down bolts) subjected to lateral loading, or that may become subjected to lateral loading through such events as the seizure of bearings or damage to shear keys, shall be adequately confined to prevent splitting of the surrounding concrete.

4.12.9 Anti-graffiti finish

Environmentally and structurally friendly anti-graffiti coatings (either permanent or sacrificial) with a design life of at least 10 years shall be applied to all new structures if required by the road controlling authority. The coatings will require approval by the road controlling authority prior to use on the works. The extent of application for each element of the structures shall be:

- 1.2m from an accessible top edge
- 2.7m above adjacent ground level or base level, and
- 1.5m horizontally from an accessible substructure element
- both faces of a rigid traffic barrier.

The extent of the application shall be increased where required for urban design.

**4.12.10
Accommodation of
signage and lighting
columns**

Any lighting columns and the posts of signs provided on structures shall be located on the outside (non-traffic side) of the side protection barriers.

On bridges with rigid barriers the horizontal clearance to posts and columns from the base of the traffic face of the side protection barrier shall be not less than 1.1m regardless of whether the barrier/deck connections are frangible or not. Clearances to posts and columns on bridges with semi-rigid barriers should be considered on a case-by-case basis and detailed in the structure design statement.

Signs and lighting overhanging the carriageway shall maintain the vertical clearances from the carriageway specified in figure A4.

**4.12.11 Deck
surfacing**

Bridge decks comprised of precast components will generally have an irregular concrete surface due to the variations in thickness and hog between adjacent units. An asphaltic levelling course shall be applied to provide smooth surfaces conforming to the design longitudinal profile and transverse crossfalls of the bridge with allowance made for the thickness of the final surfacing to be applied subsequently. The thickness of the levelling course should approach the practical minimum required to enable its laying. Also a tack coat, generally an emulsion, is required to ensure adhesion between the bridge deck and the asphaltic levelling course.

Bridge decks cast in situ should generally be constructed to the design longitudinal profile and transverse crossfalls of the bridge with allowance made for the thickness of the final surfacing and should not require application of an asphaltic levelling course. Where supported on precast concrete or steel beams, paps constructed between the top surface of the beams and soffit of the deck should be used to adjust the level of the deck to the desired profile where necessary.

The final deck surfacing shall match the surfacing applied on the bridge approaches to maintain consistency in the visual appearance and driving and braking characteristics of the surfacing.

Figure 4.5: Date and loading panel HN-HO-72 loading

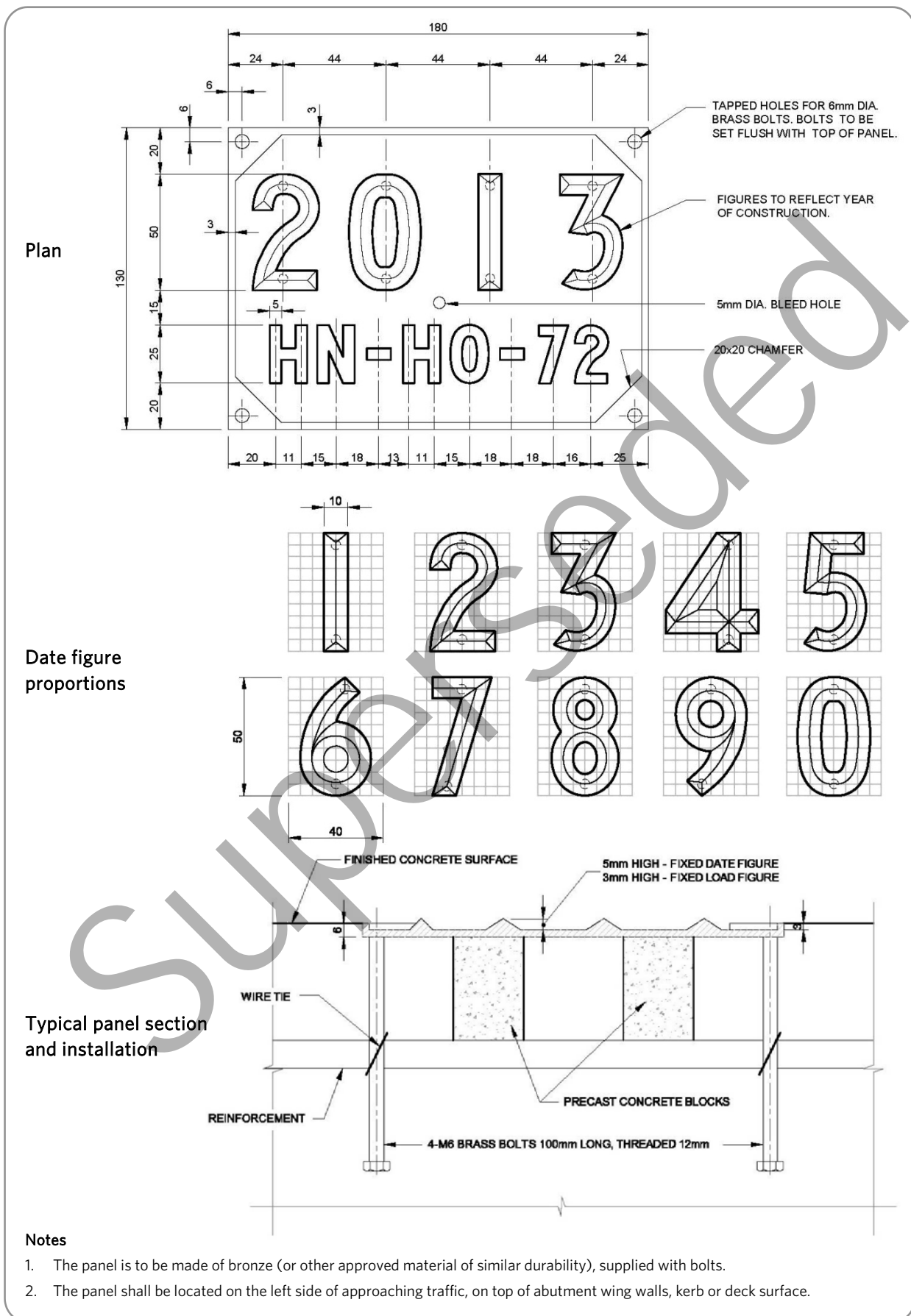

4.13 References

- (1) Standards New Zealand NZS 3101.1&2:2006 *Concrete structures standard*. (Incorporating Amendment No. 3: 2017)
- (2) Standards New Zealand NZS 3122:2009 *Specification for Portland and blended cements (General and special purpose)*.
- (3) Standards Australia and Standards New Zealand jointly AS/NZS 3582. _____ *Supplementary cementitious materials*
Part 1:2016 Fly ash
Part 2:2016 Slag – Ground granulated iron blast furnace (AS 3582.2)
Part 3:2016 Amorphous silica.
- (4) Standards Australia and Standards New Zealand jointly AS/NZS 1170.0:2002 *Structural design actions*. Part 0 General principles.
- (5) Standards New Zealand NZS 3109:1997 *Concrete construction*.
- (6) Roads and Maritime Services (2013) *Concrete work for bridges*. QA specification B80, Sydney, NSW, Australia.
- (7) Standards Australia AS 1012.13:2015 *Methods of testing concrete*. Part 13 Determination of the drying shrinkage of concrete for samples prepared in the field or in the laboratory.
- (8) National Institute of Water and Atmospheric Research *ClifFlo – The national climate database*. Last accessed 28 September 2018.
<<http://cliflo.niwa.co.nz/>>.
- (9) Standards Australia AS 5100.5:2017 *Bridge design*. Part 5 Concrete.
- (10) International Organization for Standardization ISO 15835-1:2009 *Steels for the reinforcement of concrete - Reinforcement couplers for mechanical splices of bars*. Part 1 Requirements.
- (11) International Organization for Standardization ISO 15698-1:2012 *Steel for the reinforcement of concrete - Headed bars*. Part 1 Requirements.
- (12) International Organization for Standardization ISO 15835-2:2009 *Steels for the reinforcement of concrete - Reinforcement couplers for mechanical splices of bars*. Part 2 Test methods.
- (13) International Organization for Standardization ISO 15698-2:2012 *Steel for the reinforcement of concrete - Headed bars*. Part 2 Test methods.
- (14) Standards Australia and Standards New Zealand jointly AS/NZS 4671:2001 *Steel reinforcing materials*.
- (15) Standards Australia AS 1544.2-2003 (R2017) *Methods for impact tests on metals*. Part 2 Charpy V-notch.
- (16) Standards Australia and Standards New Zealand jointly AS/NZS 3678:2016 *Structural steel – Hot-rolled plates, floorplates and slabs*. (Incorporating Amendment No. 1: 2016)
- (17) American Association of State Highway and Transportation Officials (2014) *LRFD Bridge design specifications, customary U.S. units, 7th edition*. Washington DC, USA.
- (18) Standards New Zealand NZS 3101 Parts 1 and 2:1995 *Concrete structures standard – The design of concrete structures*. Replaced by NZS 3101.1&2:2006.

- (19) Concrete Institute of Australia (2007) *CIA Z3 Grouting of Prestressing Ducts*. Sydney, NSW, Australia.
- (20) Federation International du Béton (2000) *Corrugated plastic ducts for internal bonded post-tensioning*. fib Bulletin 7, Lausanne, Switzerland.
- (21) Federal Highway Administration (2013) *Post-tensioning tendon installation and grouting manual*. US Department of Transportation, Washington DC, USA.
- (22) The Concrete Society (2010) *Durable post-tensioned concrete structures*. Technical report 72, The Concrete Society, United Kingdom.
- (23) Standards New Zealand NZS 3404 Parts 1 and 2:1997 *Steel structures standard*.
- (24) Standards Australia and Standards New Zealand jointly AS/NZS 5100.6:2017 *Bridge design*. Part 6 Steel and composite construction.
- (25) Standards Australia and Standards New Zealand jointly AS/NZS 5131:2016 *Structural steelwork - Fabrication and erection*.
- (26) Standards New Zealand NZS 3404.1:2009 *Steel structures standard*. Part 1 Materials, fabrication, and construction. Withdrawn.
- (27) NZ Transport Agency (2013) *Steel-concrete composite bridge design guide*. Research report 525, Wellington.
- (28) Standards Australia AS 5100.6-2004 *Bridge design*. Part 6 Steel and composite construction. Superseded.
- (29) Standards Australia AS 5100.1:2017 *Bridge design*. Part 1 Scope and general principles.
- (30) Standards Australia AS 5100.2:2017 *Bridge design*. Part 2 Design loads.
- (31) Standards Australia AS 4100-1998 (R2016) *Steel structures*.
- (32) New Zealand National Society for Earthquake Engineering (1985) *Seismic design of steel structures*. Deliberations of the society's study group, Bulletin of New Zealand National Society for Earthquake Engineering, December 1985.
- (33) NZ Transport Agency (2017) *Protective coatings for steel bridges: a guide for bridge and maintenance engineers*. Wellington.
- (34) Standards Australia and Standards New Zealand jointly AS/NZS 2312: _____ *Guide to the protection of structural steel against atmospheric corrosion by the use of protective coatings*
Part 1:2014 Paint coatings
Part 2:2014 Hot dip galvanizing
Part 3 Thermally sprayed metallic coatings (In prep.)
- (35) Standards New Zealand SNZ TS 3404:2018 *Durability requirements for steel structural and components*.
- (36) New Zealand Heavy Engineering Research Association (2011) *New Zealand steelwork and corrosion coatings guide*. Report R4-133, Manukau City.
- (37) New Zealand Heavy Engineering Research Association (2017) *Design guide for bridges in Australia – Weathering steel*. Manukau City.
- (38) New Zealand Heavy Engineering Research Association (2005) *New Zealand weathering steel guide for bridges*. Report R4-97, Manukau City.

- (39) International Organization for Standardization ISO 9223:2012 *Corrosion of metals and alloys – Corrosivity of atmospheres – Classification, determination and estimation*.
- (40) ASTM G50 – 10(2015) *Standard practice for conducting atmospheric corrosion tests on metals*. ASTM International, West Conshohocken, PA, USA.
- (41) The Society for Protective Coatings and NACE International jointly (2007) SSPC SP 6/NACE No. 3 *Commercial blast cleaning*. Pittsburgh, PA, USA.
- (42) Standards Australia AS 1112: _____ *ISO metric hexagon nuts*
Part 1:2015 Style 1 – Product grades A and B
Part 2:2015 Style 2 – Product grades A and B
Part 3:2015 Product grade C
Part 4:2015 Chamfered thin nuts – Product grades A and B.
- (43) Standards Australia AS 1237.1-2002 (R2015) *Plain washers for metric bolts, screws and nuts for general purposes*. Part 1 General plan.
- (44) British Standards Institution BS 4486:1980 *Specification for hot rolled and hot rolled and processed high tensile alloy steel bars for the prestressing of concrete*.
- (45) Standards Australia AS 5100.9:2017 *Bridge design*. Part 9 Timber.
- (46) Standards New Zealand NZS 3603:1993 *Timber structures standard*. Under revision.
- (47) Standards Australia AS 1720.1-2010 *Timber structures*. Part 1 Design methods.
- (48) Standards Australia AS 1720.2-2006 *Timber structures*. Part 2 Timber properties.
- (49) Standards Australia and Standards New Zealand jointly AS/NZS 2878:2000 *Timber – Classification into strength groups*.
- (50) Standards Australia and Standards New Zealand jointly AS/NZS 1664.1:1997 *Aluminium structures*. Part 1 Limit State Design.
- (51) Standards Australia AS 5100.4:2017 *Bridge design*. Part 4 Bearings and deck joints.
- (52) California Department of Transportation (2013) *Seismic design criteria*. Version 1.7. Sacramento, CA, USA.
- (53) Highways England (1994) BD 33/94 *Expansion joints for use in highway bridge decks*. TSO, London, United Kingdom.
- (54) Bruce SM and Kirkcaldie DK (2000) *Performance of deck expansion joints in New Zealand road bridges*. Research report 186, NZ Transport Agency, Wellington.
- (55) Burke MP (1989) *Bridge deck expansion joints*. National Cooperative Highway Research Program Synthesis of Highway Practice 141, Transportation Research Board, Washington DC, USA.
- (56) NZ Transport Agency (2015) *Criteria and guidance for the design of integral bridges in New Zealand*. Research report 577, Wellington.
- (57) Highways England (2003) BA 42/96 Amendment No. 1 *The design of integral bridges*. TSO, London, United Kingdom. Withdrawn.
- (58) Applied Technology Council and Multidisciplinary Center for Earthquake Engineering Research (2003) *Recommended LRFD guidelines for the seismic design of highway bridges*, MCEER/ATC 49. Buffalo NY, USA.

- (59) Khalili-Tehrani P, Taciroglu E and Shamsabadi A (2010) *Backbone curves for passive lateral response of walls with homogenous backfills*. Published in *Soil-foundation-structure interaction* – Orense, Chouw & Pender (eds), Taylor & Francis Group, London, United Kingdom.
- (60) Highways England (2001) BD 57/01 *Design for durability*. TSO, London, United Kingdom.
- (61) Highways England (2001) BA 57/01 *Design for durability*. TSO, London, United Kingdom.
- (62) Highways England (1987) BD 30/87 *Backfilled retaining walls and bridge abutments*. TSO, London, United Kingdom. Withdrawn.
- (63) Highways England (2001) BD 31/01 *The design of buried concrete box and portal frame structures*. TSO, London, United Kingdom.
- (64) Highways England (1992) BD 24/92 *The design of concrete highway bridges and structures. Use of BS 5400: Part 4: 1990*. TSO, London, United Kingdom. Not in use. (See Highways England (2015) BD 44/15 *The assessment of concrete highway bridges and structures*. TSO, London, United Kingdom.)
- (65) Highways England (2001) BD 37/01 *Loads for highway bridges*. TSO, London, United Kingdom.
- (66) National Institute of Water and Atmospheric Research New Zealand *mean annual temperature (°C), 1971 – 2000*. Last accessed 28 September 2018. <www.niwa.co.nz/education-and-training/schools/resources/climate/overview>.
- (67) British Standards Institution BS 8002:1994 *Code of practice for earth retaining structures*. Superseded, withdrawn.
- (68) British Standards Institution BS EN 1997-1:2004+A1:2013 *Eurocode 7. Geotechnical design. Part 1 General rules*.
- (69) NZ Transport Agency (1997) TNZ F/01 *Earthworks construction*. Wellington.
- (70) NZ Transport Agency (2013) NZTA F2 *Pipe subsoil drain construction*. Wellington.
- (71) NZ Transport Agency (2003) TNZ F/06 *Fabric wrapped aggregate subsoil drain construction*. Wellington.
- (72) Standards Australia and Standards New Zealand jointly AS/NZS 2041: _____ *Buried corrugated metal structures*
Part 1:2011 Design methods (Incorporating Amendment No. 1: 2018)
Part 2:2011 Installation
Part 3 Assessment of existing structures (In prep.)
Part 4:2010 Helically formed sinusoidal pipes
Part 5 Helically formed ribbed pipes (In prep.)
Part 6:2010 Bolted plate structures
Part 7 Bolted plate structures with transverse stiffeners (In prep.)
Part 8 Metal box structures (In prep.).
- (73) Standards Australia and Standards New Zealand jointly AS/NZS 3725:2007 *Design for installation of buried concrete pipes*.
- (74) Standards Australia and Standards New Zealand jointly AS/NZS 4058:2007 *Precast concrete pipes (pressure and non-pressure)*.

- (75) Austroads (2011) *Guidelines for design, construction, monitoring and rehabilitation of buried corrugated metal structures*, AP-T196-11. Sydney, NSW, Australia.
- (76) Wang J (1993) *Seismic design of tunnels*. Monograph 7, Parsons Brinckerhoff Quade and Douglas Inc, New York, NY, USA.
- (77) Federal Highway Administration (2011) *LRFD Seismic analysis and design of transportation geotechnical features and structural foundations*. NHI course no. 130094 reference manual, Geotechnical Engineering Circular 3, publication FHWA-NHI-11-032, US Department of Transportation, Washington DC, USA.
- (78) Wood JH (2005) *Earthquake design of rectangular underground structures*. Proceedings of the 2005 NZ Society for Earthquake Engineering Annual Conference, Wairakei Resort, Taupo.
- (79) Penzien J (2000) *Seismically induced racking of tunnel linings*. Earthquake Engineering and Structural Dynamics, volume 29.
- (80) Nishioka T and Unjoh S (2003) *A simplified evaluation method for the seismic performance of underground common utility boxes*. Proceedings of the 2003 Pacific Conference on Earthquake Engineering, Auckland.
- (81) Wood JH (2004) *Earthquake design procedures for rectangular underground structures*. Project report to Earthquake Commission, EQC project no. 01/470, rev B.
- (82) Standards New Zealand NZS 4402:1986 *Methods of testing soils for civil engineering purposes - Soil tests*.
- (83) Standards New Zealand NZS 4402.4.1.1:1986 *Soil compaction tests - Determination of the dry density/water content relationship - Test 4.1.1* New Zealand standard compaction test.
- (84) Standards New Zealand NZS 4402.4.1.2:1986 *Soil compaction tests - Determination of the dry density/water content relationship - Test 4.1.2* New Zealand heavy compaction test.
- (85) Standards New Zealand NZS 4402.4.1.3:1986 *Soil compaction tests - Determination of the dry density/water content relationship - Test 4.1.3* New Zealand vibrating hammer compaction test.
- (86) Standards New Zealand NZS 4402.4.2.1:1988 *Soil compaction tests - Determination of the minimum and maximum dry densities and relative density of a cohesionless soil - Test 4.2.1* Minimum dry density.
- (87) Standards New Zealand NZS 4402.4.2.2:1988 *Soil compaction tests - Determination of the minimum and maximum dry densities and relative density of a cohesionless soil - Test 4.2.2* Maximum dry density.
- (88) Oakden GJ (1977) *Highway surface drainage: Design guide for highways with a positive collection system*. Roading Directorate, Ministry of Works and Development, Wellington.
- (89) National Institute of Water and Atmospheric Research *High intensity rainfall design system (HIRDS)* version 3. Last accessed 28 September 2018. <<http://hirds.niwa.co.nz/>>.
- (90) Ministry for the Environment (2008) *Climate change effects and impacts assessment: A guidance manual for local government in New Zealand - 2nd edition*. Wellington.

- (91) Tomlinson AI (1980) *The frequency of high intensity rainfalls in New Zealand, part 1*. Water and Soil Technical Publication 19, Ministry of Works and Development, Wellington.
 - (92) NZ Transport Agency (2010) *NZTA F3 Pipe culvert construction*. Wellington.
-

Superseded

5.0 Earthquake resistant design of structures

In this section

	Section	Page
5.1	Scope and design philosophy	5-2
5.2	Design earthquake loading and ductility demand	5-7
5.3	Analysis methods – general	5-15
5.4	Displacement-based analysis methods	5-25
5.5	Force based analysis methods	5-31
5.6	Member design criteria and foundation design	5-36
5.7	Provision for relative displacements	5-53
5.8	Tsunami effects on coastal bridges	5-57
5.9	References	5-63

5.1 Scope and design philosophy

5.1.1 Scope and terminology

This section applies to the structural design of structures for earthquake resistance where the structures are composed of reinforced or prestressed concrete, steel or aluminium, timber, or other advanced engineering materials such as fibre reinforced composites, and include bridges, culverts, stock underpasses, subways and retaining walls. This section excludes the design of earth embankments and slopes for earthquake resistance, which is covered by section 6.

For the structural design of bridge abutments, both integral and non-integral, and retaining walls this section shall apply. The earthquake resistant design of non-integral bridge abutments and retaining walls for overall stability and for the limitation of displacements due to sliding and soil deformation, which are primarily geotechnical design in nature, shall comply with section 6.

The terminology: damage control limit state (DCLS) and collapse avoidance limit state (CALS) are adopted in this manual as more appropriately representing the limit states applicable to seismic resistance. The intensity of seismic response corresponding to the damage control limit state largely equates to the ultimate limit state as specified by NZS 1170.5 *Structural design actions* part 5 Earthquake actions – New Zealand⁽¹⁾, except that the upper bound and the seismic intensity for Northland have been amended by 5.2.2, and for geotechnical structures covered by section 6 magnitude weighting is not applied. The intensity of seismic response corresponding to the collapse avoidance limit state is taken to be 1.5 x DCLS subject to the upper bound limit specified by 5.2.2 and may be considered to be what is commonly referred to as the maximum considered earthquake (MCE). It should be noted that the performance requirements associated with these limit states for highway structures differ from those for other structures covered by NZS 1170.5⁽¹⁾.

5.1.2 Objective

The primary objectives of seismic design shall be to ensure life safety and that the structure can safely perform its function of maintaining communications after a seismic event. The extent to which this is possible will depend on the severity of the event, and thus by implication on its return period.

For design purposes, structures shall be categorised according to their importance or the importance of the highway on which they are located, and assigned a return period factor related to the seismic ground motion return period. This will define the design earthquake hazard and the earthquake loading as defined in 5.2.

Performance expectations at the three earthquake intensity levels outlined below and in table 5.1 require philosophic consideration in selecting the structural form and in detailing, and should be discussed in the structure options report and structure design statement.

- a. The damage control limit state (DCLS) event: After exposure to a seismic event of design (DCLS) severity, the structure shall be usable by emergency traffic within three days, although damage may have occurred, and some temporary repairs may be required to enable use by vehicles. Permanent repair to reinstate capacity for all design actions including for at least one subsequent seismic event of design (DCLS) severity shall be economically feasible. (The performance expectations for any such subsequent event may be considered as being those for a CALS event as described in item (c).) Where settlement is expected to occur, reinstatement of the structure's geometry to provide an acceptable level of service for traffic and to reinstate required clearances shall also be economically feasible. (Refer also to 5.1.3 for further explanation of this limit state.)

5.1.2 continued

- b. The serviceability limit state (SLS) event: After an event with a return period significantly less than the design (DCLS) value, damage should be minor, and there should be no more than minimal disruption to traffic (eg temporary speed restrictions and temporary lane closures to facilitate repairs such as the reinstatement of deck joint seals).
- c. The collapse avoidance limit state (CALC) event: After an event with a return period significantly greater than the design (DCLS) value, the structure should not collapse, although damage may be extensive. It may be usable by emergency traffic after temporary repairs such as propping. The structure may be capable of permanent repair, although a lower level of loading may be acceptable.

Table 5.1: Seismic performance requirements

	Earthquake severity		
	SLS earthquake (as 5.1.2(b)) Return period factor = $R_u/4$	DCLS earthquake (as 5.1.2(a)) Return period factor = R_u	CALS earthquake (as 5.1.2(c)) ¹ Return period factor = $1.5R_u$
Post-earthquake function - immediate	Minimal disruption to traffic. Operational functionality is maintained	Usable by emergency traffic ² within three days	May be usable by emergency traffic ² after temporary repair
Post-earthquake function - after reinstatement	Minimal reinstatement necessary to cater for all design-level actions. All damage to be repairable within a period of one month	Feasible to economically reinstate to a capacity sufficient to avoid collapse under a repeat design-level earthquake, and for serviceability for traffic	May be capable of permanent repair, but possibly with reduced load capacity
Acceptable damage	No damage to primary structural members. Damage to secondary and non-structural elements shall not be such as to impede the operational functionality of the structure. Deck joint seals may be dislodged but should be readily reinstated. Knock-off elements should not be damaged or dislodged	Damage may be significant; temporary repair may be required	Damage may be extensive; collapse prevented

Notes

1. The CALS earthquake event need not be taken to exceed an upper bound limit event corresponding to $Z \times$ Return Period Factor = 1.05
2. Usable by emergency traffic means able to carry two lanes of HN (normal) loading utilising load combination 4 (overload) factors with an impact factor appropriate for a speed of 30 km/h (see 7.2.2), in conjunction with the predicted post-earthquake settlements, including differential settlements.
3. The operational functionality and extent of damage incurred at each limit state shall be treated as absolute requirements. Repairability and the time taken to accomplish repairs may be regarded as aspirational.

In general, design of structures for the DCLS is expected to result in satisfactory performance at the SLS without need for specific consideration of the SLS except as specified in 5.7 for the design of movement joints. Exceptions may arise when between the SLS and DCLS a significant reduction in the structure's initial stiffness occurs reducing the structure's seismic response, eg due to liquefaction.

5.1.2 continued

Note that the performance of a structure in a particular earthquake cannot be deterministically predicted because of the high variability and uncertainty associated with earthquake ground movements and the response of structures to these movements. However the available empirical damage data indicates that the likelihood of structures designed in accordance with this *Bridge manual* not achieving the performance standards is low.

5.1.3 Maintenance of structural integrity

Bridge, culvert, stock underpasses and subway structures shall be designed to remain stable against excessive sliding or overturning in earthquakes of CALS magnitude. Limited sliding of retaining walls is permitted as specified in section 6 but they shall remain stable against overturning in CALS events.

All elements of a structure shall be detailed to maintain their integrity and to continue to perform in either an elastic or ductile manner under earthquake response exceeding the DCLS, and up to the CALS. Providing that the conditions of support of the structure and the nature of loading on the structure do not change as earthquake response increases from the DCLS up to the CALS (eg as may arise due to liquefaction of the ground or due to slope failure or movement), for the strength design of reinforced concrete or steel structural elements in ductile and limited ductile structures this may be assumed to be satisfied by designing for the DCLS design loading, applying the capacity design requirements of 5.6.1 and the ductile detailing requirements specified herein, and avoidance of situations that may lead to brittle failure of elements or connections developing. However, the degradation of the concrete contribution to the shear strength at plastic hinge locations with increasing curvature ductility demand shall be taken into account and adequate total shear strength provided for the CALS as specified by 5.6.3.

For other elements, such as elastomeric bearings, mechanical energy dissipation devices, and soil structures providing support and restraint, their ability to maintain their integrity and stability under response to earthquakes exceeding the DCLS event, shall be considered and collapse avoidance of the structure as a whole confirmed. Where the mode of behaviour of the structure changes, or loading conditions acting on the structure change, from that applying at the DCLS in events greater than the DCLS event, collapse avoidance under the CALS event shall be confirmed. Such situations may arise, for example, when:

- an elastic structure develops in-elastic behaviour (as discussed below)
- when supporting ground undergoes some degree of failure altering the support provided to the structure and/or imposing soil lateral spread loading onto the structure
- when bearings or base isolation devices exceed their displacement capacities.

In considering the performance of the structure at the CALS, the factor of safety of the structure against overturning shall equal or exceed 1.0. Sliding of the structure is permissible providing it does not pose a risk to human life. The structure as a whole, based on probable material strengths and capacity reduction factors of $\phi=1.0$ for steel and concrete elements, and for soil elements supporting or restraining the structure a capacity reduction factor of $\phi=0.75$ (allowing for the greater uncertainty associated with the strength of soil elements) shall retain sufficient integrity against collapse, though individual elements within the structure may fail with the forces that they were carrying being redistributed within the structure.

5.1.3 continued

Care shall be taken to ensure that detailing practices recognize the potential for inelastic response even when the bridge is designed to respond elastically. When plastic hinges do not form at the DCLS event, in order to ensure collapse avoidance in earthquakes exceeding the design DCLS event, bridge elements likely to develop plastic hinging in such events shall be detailed for ductility as required by the referenced materials design standards NZS 3101 *Concrete structures standard*⁽²⁾ and NZS 3404:1997 *Steel structures standard*⁽³⁾ for structures of limited ductility and capacity design shall be applied to ensure shear failures are avoided.

The requirements of section 6 shall be complied with in considering the interaction between the structure and its supporting ground under earthquake response and in situations where ground instability may arise.

The design of any structure located in an area which is susceptible to earthquake induced liquefaction, or which is located within 200m of an active fault with a recurrence interval of 2000 years or less, shall recognise the large movements which may result from settlement, rotation or translation of substructures. To the extent practical and economic, and taking into consideration possible social consequences, measures shall be incorporated to mitigate against these effects. Mitigation measures may include:

- alteration of the route to enable relocation of the structure to another less vulnerable site with better ground conditions
- at locations where crossing of a fault is unavoidable, or liquefaction is likely, adoption of a structural form more tolerant to fault movement or lateral spreading and able to be more rapidly reinstated should fault or lateral spreading movement occur (eg a reinforced soil embankment in preference to a bridge).

5.1.4 Background and commentary

The earthquake provisions included in this edition of the *Bridge manual* have been developed with reference to:

- AS/NZS 1170.0 *Structural design actions* part 0 General principles⁽⁴⁾
- NZS 1170.5 *Structural design actions* part 5 Earthquake actions – New Zealand⁽¹⁾
- *Seismic design and retrofit of bridges*⁽⁵⁾
- *Displacement-based seismic design of structures*⁽⁶⁾
- NZS 3101 *Concrete structures standard*⁽²⁾.

In the specification of design earthquake loadings, extensive reference is made to NZS 1170.5⁽¹⁾ in this section of the *Bridge manual*. Where appropriate, text has been included but generally only where modification has been made. The reader is referred to NZS 1170.5 supplement 1 *Structural design actions* Part 5 Earthquake actions – New Zealand – Commentary⁽⁷⁾ for background information relating to NZS 1170.5⁽¹⁾.

Within this section of the *Bridge manual*, the term “damage control limit state” (DCLS) is equated to the term ultimate limit state (ULS) as applied by NZS 1170.5⁽¹⁾, but is adopted to more appropriately represent the limit state under consideration. The following extract from the Commentary to NZS 1170.5⁽⁷⁾ explains what this limit state represents:

Given the current state of knowledge of the variables and the inherent uncertainties involved in reliably predicting when a structure will collapse, it is not currently considered practical to either analyse a building to determine the probability of collapse or base a code verification method around a collapse limit state. It is therefore necessary to adopt a different approach for the purposes of design.

5.1.4 continued

It is possible to consider a limit state at a lower level of structural response, at a level where structural performance is more reliably predicted, and one that is familiar to designers and then rely on margins inherent within design procedures to provide confidence that acceptable collapse and fatality risks are achieved. In this Standard [NZS 1170.5⁽¹⁾] this limit state is referred to as the ultimate limit state (ULS).

It is inherent within this Standard [NZS 1170.5⁽¹⁾] that, in order to ensure an acceptable risk of collapse, there should be a reasonable margin between the performance of material and structural form combinations at the ULS and at the collapse limit state. For most ductile materials and structure configurations it has been assumed that a margin of at least 1.5 to 1.8 will be available. This is intended to apply to both strength and displacement.

In this edition of the *Bridge manual* the following significant departures from the previous edition and from the approaches advocated by the NZS standards have been introduced:

- Where bridges are to be designed to be ductile or to possess limited ductility, displacement-based design, as presented in the book *Displacement-based design of structures*⁽⁶⁾ has been adopted as the preferred method of analysis, unless other design analysis procedures are agreed to by the road controlling authority.
- The use of a structural performance factor (S_p) to modify the design seismic loading has been discarded.
- The design of potential plastic hinges within structures for flexure under seismic actions is to be based on the use of expected material strengths with no strength reduction factor applied. In the design of potential plastic hinge regions for flexure, seismic moment demands need not be combined with non-seismic demands when determining the required flexural capacity. For the assessment of overstrength actions to be designed in applying capacity design, maximum feasible material strengths to be adopted are specified.
- A consequence of the above approach to the design of plastic hinges is that three scenarios need to be considered in the design of plastic hinges and of non-yielding elements:
 - i. Non-seismic load combination actions as they act prior to any seismic response.
 - ii. DCLS earthquake response with plastic hinges designed for horizontal earthquake response moments, axial loads and shears and permanent load axial loads and shears. Non-yielding elements are capacity designed for earthquake overstrength actions plus permanent load actions. The redistribution of permanent load actions as a result of relief of their moments at plastic hinge locations needs to be taken into account.
 - iii. Post DCLS earthquake response with elements (including plastic hinge regions) designed for the non-seismic load combinations but taking into account the redistributed permanent load actions as a result of yielding during earthquake response.

For the design of ductile, yielding, reinforced concrete elements, the strain limits, confinement reinforcement requirements, and method of design for shear outlined in *Seismic design and retrofit of bridges*⁽⁵⁾ have been adopted in preference to the requirements specified by NZS 3101⁽²⁾ though there are exceptions where the NZS 3101⁽²⁾ requirements have been retained. Capacity design has been specified to be required whenever ductile yielding is expected, regardless of the level of structure ductility, to ensure shear failure, other types of brittle failure, and plastic hinging in non-ductile members does not occur.

5.2 Design earthquake loading and ductility demand

5.2.1 Design earthquake loading

a. DCLS design earthquake loading

The design earthquake loadings are defined by response spectra appropriate to the site location, including proximity to major active faults, the site subsoil conditions, the specified annual probability of exceedance of the design earthquake determined from 2.1.3, and the modification factors for damping and ductility.

For force-based design, design spectral accelerations for horizontal earthquake response are derived from the site hazard elastic spectra determined in accordance with 5.2.2 or 5.2.5, factored as specified by 5.5.1 and 5.5.3 for foundation damping and structural ductility respectively.

For displacement-based design, design spectral displacements for horizontal earthquake response are derived from the site hazard elastic acceleration response spectra determined in accordance with 5.2.2 or 5.2.5, factored as specified in 5.2.4(a) and (b), and factored as specified by 5.4.2 to take into account damping.

Vertical earthquake response is determined in accordance with 5.2.3 for force-based design or 5.2.4(c) for displacement-based design.

The need to increase the design earthquake loading due to possible local site effects or location shall be considered. Where significant these aspects and their implications for the design shall be discussed in the structure design statement.

b. CALS earthquake loading

Where consideration of the CALS is required the CALS earthquake loading shall be taken as 1.5 times the DCLS design acceleration or displacement response spectra determined as outlined in 5.2.1(a), but with an upper bound limit as specified in 5.2.2(c).

5.2.2 Site hazard elastic acceleration response spectra for horizontal loading

The site hazard elastic response spectrum for horizontal loading shall be determined in accordance with section 3.1 of NZS 1170.5⁽¹⁾ as modified herein, for the annual probability of exceedance corresponding to the importance level of the structure specified in table 2.1, or by a site specific seismic hazard study in accordance with 5.2.5.

(Note that over the period range from $T=0$ to $T=0.5$ seconds, the NZS 1170.5⁽¹⁾ elastic site hazard spectra incorporate magnitude weighting, and the spectra correspond to 5% damping.)

a. Hazard factor (Z)

The hazard factor (Z) shall be derived from NZS 1170.5⁽¹⁾ figures 3.3 and 3.4, and/or table 3.3 with the hazard factor values for Auckland and Northland replaced by table 5.2 and figure 5.1 of this manual, north of the 0.15 contour of figure 5.1.

For the damage control limit state, the product ZR_u shall not be taken as less than 0.13.

Table 5.2: Hazard factors (Z) for Northland

Location	Z Factor	Location	Z Factor	Location	Z Factor
Kaitaia	0.06	Dargaville	0.07	Manakau City	0.12
Paihia / Russell	0.06	Warkworth	0.09	Waiuku	0.11
Kaikohe	0.06	Auckland	0.10	Pukekohe	0.12
Whangarei	0.07				

5.2.2 continued

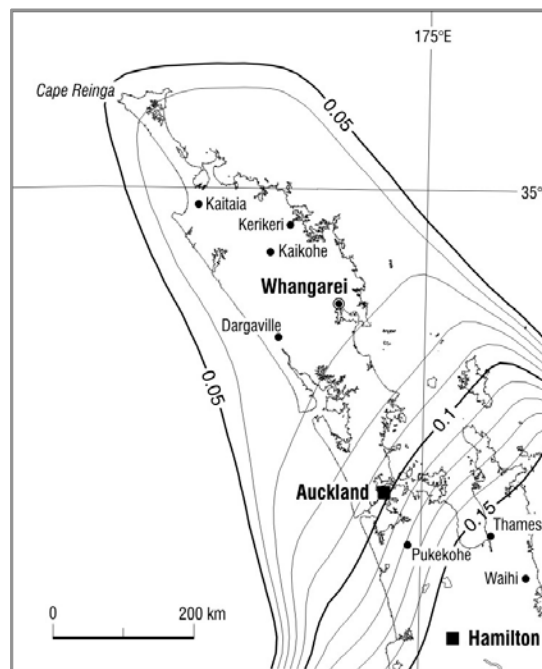
Figure 5.1: Hazard factors (Z) for Northlandb. Return period factor (R_u)

NZS 1170.5⁽¹⁾ clause 3.1.5, Return period factor, shall be amended to read as follows:

The return period factor R_u for the damage control limit state, shall be obtained from table 3.5 of NZS 1170.5⁽¹⁾, or table 5.3 of this manual as appropriate, for the annual probability of exceedance appropriate for the importance level of the structure as prescribed in tables 2.1 to 2.3 of this manual.

Table 5.3: Return period factor (supplemental to table 3.5 of NZS 1170.5⁽¹⁾)

Required annual probability of exceedance	R_u
1/1500	1.5
1/700	1.15

c. Upper bound for ZR_u

The limit placed on ZR_u in NZS 1170.5⁽¹⁾ clause 3.1.1 of $ZR_u \leq 0.7$ shall be disregarded, as for bridges it is desirable to not only avoid collapse, but also to limit the extent of damage at the DCLS. For both the DCLS and the CALS, the upper bound earthquake event shall be taken to be one corresponding to $ZR_u = 1.05$.

d. Spectral shape factor $C_h(T)$

For periods from 3s up to a long-period corner period (T_L) the spectral shape factor $C_h(T)$ for a period of T seconds shall be determined from:

$$C_h(T) = C_h(3s) \times \left(\frac{3}{T}\right) \quad 3s \leq T \leq T_L \quad (5-1)$$

$$C_h(T) = C_h(T_L) \times \left(\frac{T_L}{T}\right)^2 \quad T > T_L \quad (5-2)$$

5.2.2 continued

Where:

$C_h(3s)$ = as given by section 3.1.2 of NZS 1170.5⁽¹⁾ for the corresponding site class or site period T_{site}

$C_h(T_L)$ = as determined from equation (5-2) for the period T_L specified for the location in table 5.4.

Table 5.4: Corner periods T_L throughout New Zealand for assigned moment magnitude M_w

Region	Assigned M_w ¹	Corner period T_L (s)
Northland, Auckland	6.5	3
Waikato, Taranaki, Western Bay of Plenty, Tauranga, Rotorua	6.9	5
Elsewhere in New Zealand	7.5	≥ 10

Notes

1. Magnitudes based on those recommended for consideration in determining collapse-avoidance motions in figure 6.3, with consolidation of some regions.

5.2.3 Site hazard elastic acceleration response spectra for vertical loading

The elastic site hazard spectrum for vertical loading shall be determined in accordance with section 3.2 of NZS 1170.5⁽¹⁾.

5.2.4 Design displacement response spectra for displacement-based design

- a. Elastic displacement spectral shape factor $\Delta_h(T)$ ^{*}

The period-dependent elastic displacement spectral shape factor $\Delta_h(T)$ shall depend on the site subsoil class defined by NZS 1170.5⁽¹⁾, clause 3.1.3, unless determined by an approved site-specific earthquake hazard study.

The displacement spectral shape factor may be obtained from the acceleration spectral shape factor of NZS 1170.5⁽¹⁾, table 3.1 by use of equation (5-3) when approved site-specific hazard studies defining the displacement spectral shape are not available:

$$\Delta_h(T) = \frac{T^2}{4\pi^2} C_h(T)g \quad (\text{mm}) \quad (5-3)$$

Where:

$C_h(T)$ = the acceleration spectral shape given in table 3.1 of NZS 1170.5⁽¹⁾ for modal response spectrum and numerical integration time-history methods as modified by 5.2.2(d).

T = period (seconds)

g = gravitational acceleration (9807mm/s²).

The displacement spectral shapes for different subsoil classes resulting from equation (5-3), with minor rounding, are listed in table 5.5 and are plotted in figure 5.2.

^{*} 5.2.4(a) has been adapted from *New Zealand Seismic isolation guidelines*⁽⁸⁾ with the permission of the New Zealand Society for Earthquake Engineering, GNS Science and the Ministry of Business, Innovation & Employment.

5.2.4 continued

Table 5.5: Elastic displacement spectral shape factor $\Delta_h(T)$ (mm)

Period T (sec)	Displacement spectral shape factor $\Delta_h(T)$ (mm)			
	Site subsoil class			
	A strong rock, B rock	C shallow soil	D deep or soft soil	E very soft soil
0.0	0	0	0	0
0.05	1	1	1	1
0.075	3	4	4	4
0.1	6	7	8	8
0.2	23	29	30	30
0.3	53	66	67	67
0.4	75	94	119	119
0.5	99	124	186	186
0.56	114	143	232	232
0.6	125	156	254	268
0.7	151	189	308	365
0.8	179	224	364	477
0.9	207	259	421	604
1.0	236	295	481	745
1.5	391	490	797	1240
2.0	522	656	1060	1650
2.5	652	820	1330	2060
3.0	783	984	1590	2470
3.5	913 ¹	1150 ²	1860 ³	2890 ⁴
4.0	1040 ¹	1310 ²	2130 ³	3300 ⁴
4.5	1170 ¹	1480 ²	2390 ³	3710 ⁴
5.0	1300 ¹	1640 ²	2660 ³	4120 ⁴
6.0	1570 ¹	1970 ²	3190 ³	4950 ⁴
7.0	1830 ¹	2300 ²	3720 ³	5770 ⁴
8.0	2090 ¹	2620 ²	4250 ³	6600 ⁴
9.0	2350 ¹	2950 ²	4780 ³	7420 ⁴
10.0	2610 ¹	3280 ²	5320 ³	8250 ⁴

Notes

1. Need not exceed $\Delta_{h,A,B}(T_L)$ for the T_L value applicable for the location
2. Need not exceed $\Delta_{h,C}(T_L)$ for the T_L value applicable for the location
3. Need not exceed $\Delta_{h,D}(T_L)$ for the T_L value applicable for the location
4. Need not exceed $\Delta_{h,E}(T_L)$ for the T_L value applicable for the location

5.2.4 continued

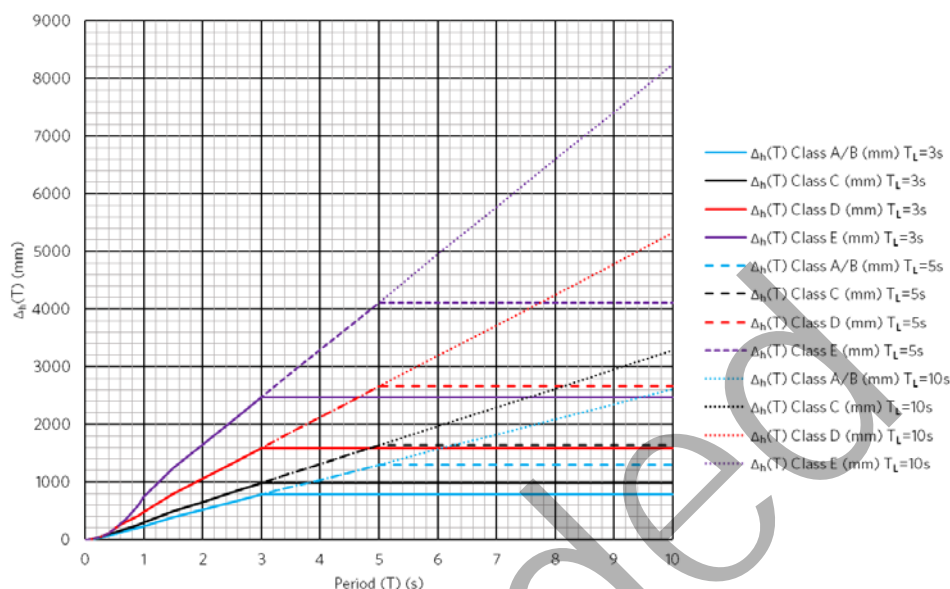
Figure 5.2: Displacement spectral shapes ($\Delta_h(T)$) for the four subsoil classes and corner periods $T_L=3s, 5s$ and $10s$ 

b. Elastic design spectra for horizontal earthquake response

The design elastic displacement spectrum for horizontal earthquake response shall be defined by the product of return period factor R_u , seismic hazard factor Z , and the spectral shape factor $\Delta_h(T)$ in accordance with equation (5-4). The requirements of 5.2.2 in respect to the hazard factor, Z , the return period factor, R_u , and the upper bound for ZR_u apply also to the derivation of displacement spectra.

$$\Delta(T) = R_u Z N(T, D) \Delta_h(T) \quad (5-4)$$

Where:

R_u = DCLS return period factor from 5.2.2(b)

Z = design seismic hazard factor, given in 5.2.2(a)

$N(T, D)$ = near fault factor given in NZS 1170.5⁽¹⁾ clause 3.1.6

$\Delta_h(T)$ = displacement spectral shape factor, given in table 5.5.

The corner-period elastic spectral displacements $\Delta(3.0)$, $\Delta(5.0)$ and $\Delta(10.0)$ are defined as the value of equation (5-4) at the periods of 3.0 seconds, 5.0 seconds and 10.0 seconds respectively.

c. Elastic design spectrum for vertical response

The displacement spectrum $\Delta_v(T)$ for vertical response shall be obtained by use of equation (5-3) with $C_h(T)$ replaced by $C_v(T)$ obtained from 5.2.3. (Note: $C_v(T)$ is derived from $C(T)$ and so incorporates the factors R_u , Z and $N(T, D)$ and is the acceleration response spectrum and not a spectral shape factor as $C_h(T)$ is.)

5.2.5 Site-specific seismic hazard studies

a. Basis for site-specific seismic hazard studies

The intensities of design ground motion specified by NZS 1170.5⁽¹⁾ and adopted by this manual have been derived from hazard analysis and are generally applicable to the design of bridges and other roading structures. However, at any given site the actual seismic hazard based on a probabilistic seismic hazard analysis may vary somewhat from the spectra specified by the standard due to a variety of factors.

5.2.5 continued

It should also be noted that the results of the hazard analysis have undergone modification in both regions of low seismicity and regions of high seismicity. In regions of low seismicity, the possibility of moderate magnitude earthquakes within 20km has been considered and results in the specified minimum ZR_u combination value of 0.13. The maximum considered earthquake (MCE) in the zone of highest seismicity represents the maximum motions considered by the NZS 1170.5⁽¹⁾ standard committee as likely to be experienced in New Zealand. The limit placed on ZR_u in NZS 1170.5⁽¹⁾ clause 3.1.1 of $ZR_u \leq 0.7$ shall be disregarded, as for bridges it is desirable to not only avoid collapse, but also to limit the extent of damage at the DCLS.

Special studies may be carried out to justify departures from the specific provisions of this manual and from NZS 1170.5⁽¹⁾. All such studies shall be undertaken in a manner consistent with the principles upon which NZS 1170.5⁽¹⁾ was developed and in accordance with the special studies principles outlined in AS/NZS 1170.0⁽⁴⁾ appendix A. In all cases the minimum provisions stated elsewhere, either below or in NZS 1170.5⁽¹⁾ shall still apply unless they too are included within the special study.

In addition to the NZS 1170.5 Commentary⁽⁷⁾, the following papers and publication provide an outline of the basis of the NZS 1170.5⁽¹⁾ provisions and more recent developments:

- *Probabilistic seismic hazard assessment of New Zealand: New active fault data, seismicity data, attenuation relationships and methods*⁽⁹⁾
- *New national probabilistic seismic hazard maps for New Zealand*⁽¹⁰⁾
- *A new seismic hazard model for New Zealand*⁽¹¹⁾
- *From hazard maps to code spectra for New Zealand*⁽¹²⁾
- *New Zealand acceleration response spectrum attenuation relations for crustal and subduction zone earthquakes*⁽¹³⁾
- *New national seismic hazard model for New Zealand: Changes to estimated long-term hazard*⁽¹⁴⁾
- *National seismic hazard model for New Zealand: 2010 update*⁽¹⁵⁾

Where a special study is undertaken to develop site-specific design spectra or for the selection of earthquake records for time history analysis, then the following limitations shall apply:

- The site-specific hazard study shall be peer reviewed by reviewers acceptable to the road controlling authority.
- Historical catalogue based seismicity and fault models shall be used.
- The modelling of the distributed seismicity component shall consider earthquakes of magnitude down to at least as low as 5.5.
- The site hazard spectra shall be based on a seismic hazard model that reflects New Zealand seismic and attenuation conditions.
- The site hazard used for the DCLS event shall be for the acceptable annual probability of exceedance based on the importance level of the structure.
- The site hazard spectrum for survival-level motions under which collapse is to be avoided (ie the CALS event) shall be scaled up by a factor of 1.5 from the DCLS design level motions corresponding to an assumed margin of safety of 1.5 resulting from the design procedures for ductile structures.
- The CALS and DCLS spectra need not exceed that calculated for 84th percentile motions from a magnitude 8.1 strike slip earthquake at zero distance.

5.2.5 continued

- Adopted 5% damped spectra shall be within $\pm 30\%$ of the design spectrum determined for the specific site from NZS 1170.5⁽¹⁾ combined with this manual, but for the CALS event, shall not be less than the 84th percentile motion resulting from a magnitude 6.5 earthquake located 20km from the site, nor for the DCLS less than $\frac{2}{3}$ of the 84th percentile motion resulting from a magnitude 6.5 earthquake located 20km from the site.
- The common practice of truncating peaked acceleration response spectra over the short period range may be applied with such truncation to be limited to not exceed 25% of the peak spectral values nor to be below the 0.4 second spectral ordinate for rock or shallow soil sites, the 0.56 second ordinate for deep or soft soil sites, or the 1.0 second ordinate for very soft soil sites as defined in NZS 1170.5⁽¹⁾ section 3.1.3.
- Possible shortcomings at long periods of the ground-motion prediction equations (GMPEs) used in the hazard analyses should be recognised^{*}. In particular, hazard spectra determined from site-specific studies should recognise the increase in the velocity-displacement corner period T_L from the default value of 3s assumed in NZS 1170.5⁽¹⁾. Depending on the GMPE models used, the site-specific spectra may not have sufficiently long T_L . If the corner period of the hazard spectrum is shorter than the T_L value given for the site location in table 5.4, it should be shown that the GMPEs have corner periods for magnitudes and distances that make sizeable contributions to the estimated hazard at the site that are at least as long as that given by the expression:

$$\log_{10} \left(\frac{T_L}{3} \right) = 0.5229(M_w - 6.5) \quad (5-5)$$

The corner period of the hazard spectrum for the return period of interest should be compared to the corner period given by equation (5-5). The magnitude M_w to be used in equation (5-5) shall be such that larger magnitudes produce no more than 20% of the estimated exceedance rate of the spectral acceleration for the period closest to the effective period T_{eff} of the system. Note that the moment magnitude M_w used to calculate T_L may be smaller than that given in table 5.4 if it is justified by deaggregation analysis, except that it may not be taken as less than 6.5 anywhere (ie T_L cannot be reduced below 3s). If the GMPE model does not satisfy this requirement on its corner period, the resulting hazard spectra should be modified by increasing spectral values for periods longer than 3s by the expressions:

$$SA(T) = SA(3s) \times \left(\frac{3}{T} \right) \quad 3s \leq T \leq T_L \quad (5-6)$$

$$SA(T) = SA(T_L) \times \left(\frac{T_L}{T} \right)^2 \quad T > T_L \quad (5-7)$$

If a site specific seismic hazard study is undertaken and results in a higher design seismic hazard spectrum than that derived from this manual together with NZS 1170.5⁽¹⁾, then the site specific hazard spectrum shall be adopted.

b. Documentation of site-specific seismic hazard studies

The results from any special study undertaken shall be presented in an appendix to the structure design statement in accordance with 2.7. The minimum details required to be included within the appendix are:

- the project geo-referenced coordinates

^{*} The final bullet point of 5.2.5(a) has been taken from *New Zealand Seismic isolation guidelines*⁽⁸⁾ with the permission of the New Zealand Society for Earthquake Engineering, GNS Science and the Ministry of Business, Innovation & Employment.

5.2.5 continued

- the organisation/individual who has undertaken the special study
- a brief outline of the experience and capability of the agency and personnel undertaking the special study
- details of the seismicity model used as the basis of the study within which the seismic signature of faults of significance to the study are to be prescribed
- a description of how background seismicity has been incorporated in the model
- the attenuation relationships used within the model and, when international attenuation relationships are used, an explanation of their appropriateness for the New Zealand setting
- details of the site classification chosen together with justification
- the raw spectral results of the study together with an explanation of any adjustments or spectral smoothing that may have been applied to arrive at the proposed design spectra
- the proposed design spectra, compared with the requirements of this manual, and
- where the study provides earthquake ground motion records that may be used for time history analysis, the basis upon which these records have been selected, how any record scale factors have been devised and the resulting spectra relating to these records, together with comment on the presence or otherwise of forward-directivity effects in any records selected.

5.2.6 Structural performance factor (S_p)

In the design of roading structures a structural performance factor shall not be applied to reduce the design actions. Where in the materials design standards a structural performance factor is permitted to be applied, the structural performance factors shall be taken as $S_p=1.0$.

5.2.7 Designing and detailing for ductility

a. Section ductility and strain limitation

At all locations of plastic hinging or other inelastic behaviour the strain limits specified by 5.3.5 shall be satisfied, irrespective of whether displacement-based or force-based design is adopted.

Where the foundations and/or bearings provide additional flexibility to the structure to that of the piers alone, the flexibility of foundations and bearings should be considered when calculating compliance with strain limits. (See *Influence of foundation on the seismic response of bridge piers*⁽¹⁶⁾ or *Seismic design and retrofit of bridges*⁽⁵⁾ for further explanation).

b. Classification of structures, and nominally ductile structures

This manual considers only three classes of structure according to their behaviour at the DCLS: fully elastic structures, structures of limited ductility, and ductile structures, as outlined in 5.6.4(a).

Nominally ductile structures, as referred to in the referenced material design standards, shall as a minimum be designed and detailed in accordance with the requirements for structures of limited ductility, with capacity design applied to protect elements not intended to yield against brittle failure.

c. Freedom to displace

All structures designed on the basis of developing ductility (ie ductile structures, and structures of limited ductility) shall possess sufficient freedom to displace to enable their design level of ductility to develop and their ductile behaviour to be maintained in earthquake events exceeding the DCLS, up to the CALS event.

5.3 Analysis methods – general

5.3.1 General

Design forces on members shall be determined from analyses that take account of the stiffness of the superstructure, bearings, piers and foundations. The design load shall be applied to the whole structure. Consideration shall be given to the effects on structural response of likely variation in both structural and foundation material properties. Consideration shall also be given to the consequences of possible yielding of components of the foundation structure or soil and of rocking or uplift of spread footings on the response and energy dissipation characteristics of the structure. The type of analysis used shall be appropriate to the form of structure being designed.

Analyses shall be undertaken for two orthogonal horizontal directions and the vertical direction. For horizontally curved bridges, one of the horizontal directions shall be the chord between the two abutments. Where appropriate, alternative orientations for the two orthogonal horizontal directions shall be considered in order to capture the maximum effects on individual structural elements. For example, where piers are founded on groups of piles, the effect of the earthquake loading acting along the diagonal of the pile group should be considered. For skewed bridges, one orientation for the two orthogonal horizontal axes to be considered should be parallel and perpendicular to the skewed alignment of the piers and abutments.

5.3.2 Combination of seismic actions from elastic analyses

For elastically responding or brittle structures, a combination of the effects of orthogonal seismic actions shall be applied to the structural elements to account for the simultaneous occurrence of earthquake shaking in two perpendicular horizontal directions. Seismic forces and moments on each of the principal axes of an element shall be derived as set out below. The absolute values of effects (forces or moments) resulting from the analyses in two orthogonal directions shall be combined to form two load cases as follows:

LOAD CASE 1: 100% of the effects resulting from analysis in direction x (eg, longitudinal) plus 30% of the effects resulting from analysis in the orthogonal direction y (eg transverse).

LOAD CASE 2: 100% of the effects resulting from analysis in direction y (eg transverse) plus 30% of the effects resulting from analysis in the orthogonal direction x (eg longitudinal).

Concurrency of loading in two perpendicular horizontal directions need not be considered for structures that are ductile (including those detailed for limited ductility) in both directions but shall be considered for structures that are ductile in only one of the two directions.

For further explanation refer to NZS 1170.5 Commentary⁽⁷⁾, clause C5.3.1.)

5.3.3 Vertical seismic response

The vertical seismic response shall be considered to act non-concurrently to horizontal seismic response.

Bridge superstructures shall be designed to remain elastic under both positive and negative vertical acceleration induced by DCLS seismic response, while collapse is to be avoided under the CALS seismic response.

A span-by-span static analysis may be used, where the span under consideration is modelled together with adjacent continuous spans, if any, at either end of the span. End support conditions at the far end of the adjacent span shall be considered fixed, if continuous over the support, or pinned, as appropriate (eg if the end of the adjacent span is simply supported at an abutment).

5.3.3 continued

Vertical seismic response moments shall be determined from the spectrum defined by 5.2.3, 5.2.4(c) or 5.2.5 which are based on a damping ratio of 0.05. The damping ratio for vertical seismic response shall be taken as 0.02 for structural steel girder superstructures (including steel truss and steel arch supported superstructures), 0.03 for prestressed concrete superstructures, and 0.05 for reinforced concrete girder superstructures. The spectrum shall be modified for structural steel girder and prestressed concrete girder superstructures by multiplying by the appropriate damping modifier M_{ξ} determined from equation (5-17).

5.3.4 Pier elastic flexibility

a. Pier yield curvature

Yield displacements and elastic stiffness of piers shall be based on the pier yield curvature. The yield curvature of the bi-linear representation of the pier moment-curvature relationship depends on the section depth D in the direction considered, and the flexural reinforcement (or structural steel) yield strain ε_y and may be approximated by equation (5-8) for most common pier shapes. For specific pier shapes a more accurate equation may be obtained from *Displacement-based seismic design of structures*⁽⁶⁾, section 3.4.2:

$$\phi_y = \frac{2.15\varepsilon_y}{D} \quad (5-8)$$

Where:

ε_y = yield strain of flexural reinforcement or structural steel based on the probable (expected) yield strength

D = section depth in the direction considered.

For piers with non-prismatic or complex prismatic section shapes the yield curvature may be determined by finite-element analysis or other means recognizing the non-linear behaviour of materials and the influence of cracking, where appropriate.

The effective elastic stiffness of a pier may be approximated by equation (5-9):

$$EI = \frac{M_N}{\phi_y} \quad (5-9)$$

Where:

M_N = moment capacity of the critical section determined in accordance with 5.6.2

ϕ_y = yield curvature defined by equation (5-8).

b. Yield displacement of piers

The yield displacement of a pier will depend on the yield curvature and the end fixity conditions at base and top, and for piers of constant section over their height may be expressed as:

$$\Delta_y = C_1 \phi_y (H + L_{sp})^2 + \Delta_{yf} \quad (5-10)$$

Where:

C_1 = coefficient dependent on the end fixity conditions (refer to C5.7.2 in *Bridge manual commentary*)

Δ_{yf} = displacement at the pier top resulting from foundation deformation

ϕ_y = yield curvature at the pier critical section

H = effective column height (see figure C5.2 in *Bridge manual commentary*)

5.3.4 continued

$$L_{sp} = \text{strain penetration length for reinforced concrete piers}$$

$$= 0.022f_{sye}d_{bl} \quad \text{at top and/or bottom of pier}$$

Where, for reinforced concrete piers:

$$d_{bl} = \text{diameter of flexural reinforcement}$$

$$f_{sye} = \text{probable (expected) yield strength of the flexural reinforcement.}$$

Where bearings are provided, the bearing deflection does not affect the pier yield displacement but will modify the displacement of the superstructure at the pier position.

(For guidance and worked examples for other pier forms, eg pile columns with plastic hinges forming below ground, refer to *Displacement-based seismic design of structures*⁽⁶⁾, section 10.3.)

5.3.5 Strain limits for the damage control limit state and the collapse avoidance limit state

Material strains at plastic hinges are due to the combination of both permanent and earthquake actions. They shall be assessed based on load combination 3A of table 3.2.

The limiting strains specified below for fully ductile structures shall be complied with at the DCLS. For reinforced concrete structures classified as limited ductile, strain limits of 0.58 times those for fully ductile structures shall apply. Where there is a need to consider strain limitation at the CALS, the strain limit adopted shall be the DCLS strain limit for concrete increased by a factor of 1.5 and for reinforcing steel the strain shall not exceed 0.08.

At potential plastic hinge locations that are inaccessible for inspection and repair (eg below water level or >2m below ground level) the allowable strain limits shall be reduced by a factor of 0.7.

a. Reinforcing steel:

Limit strain in flexural reinforcing steel in plastic hinges shall be related to the volumetric ratio of transverse reinforcement (ρ_s) in accordance with equation (5-11), and shall not exceed 50% of the strain ϵ_{sul} at maximum stress:

$$\epsilon_{sd} = 0.015 + 6(\rho_s - 0.005) \leq 0.5\epsilon_{sul} \quad (5-11)$$

Where:

$$\rho_s = \text{volumetric ratio of transverse reinforcement}$$

$$\epsilon_{sul} = \text{strain at maximum stress of longitudinal reinforcement, not to be taken as larger than 0.10 for 500E reinforcement or 0.12 for 300E reinforcement.}$$

b. Concrete compression strain:

Limit compression strain of concrete in plastic hinges shall be related to the volumetric ratio of transverse reinforcement (ρ_s) and shall not exceed the value given by equation (5-12):

$$\epsilon_{cd} = 0.004 + 1.4 \frac{\rho_s f_{sy.t} \epsilon_{sut}}{f'_{cc}} \quad (5-12)$$

Where:

$$f'_{cc} = \text{confined compression strength of the concrete, which may be taken as } 1.5f'_{ce} \text{ (} f'_{ce} = \text{expected concrete compression strength - see C5.13.1 in } \textit{Bridge manual commentary} \text{) if not calculated by a rational analysis}$$

$$f_{sy.t} = \text{lower characteristic yield stress of the transverse reinforcement}$$

5.3.5 continued

ϵ_{sut} = strain at maximum stress of transverse reinforcement, not to be taken as larger than 0.10 for 500E reinforcement or 0.12 for 300E reinforcement.

c. Structural steel strain:

Limit compression and tension strain in ductile structural steel piers shall not exceed values corresponding to the onset of buckling under cyclic reversals of stress. In the absence of definitive design information, a value of ϵ_{sd} = 0.02 may be assumed.

d. Hollow concrete piers:

The maximum concrete compression strain for hollow reinforced or prestressed piers shall not exceed the value given by equation (5-12) or 0.005.

e. Prestressing steel:

Tensile strain in prestressing steel shall not exceed the limit-of-proportionality strain (ie 0.1% proof strain).

f. Concrete infilled steel tubes:

Concrete infilled steel tubes shall satisfy the requirements of NZS 3101⁽²⁾ clause 10.3.11.6.1 to ensure that buckling of the steel tube is precluded. Otherwise the strain limits for concrete compression strain and for reinforcing steel and structural steel shall apply.

5.3.6 Limitations on displacement

Deflections of the structure under the effects of the design DCLS earthquake shall not be such as to:

- a. endanger life
- b. cause loss of function
- c. cause contact between parts if such contact would damage the parts to the extent that persons would be endangered, or detrimentally alter the response of the structure or reduce the strength of structural elements below the required strength
- d. cause loss of structural integrity.

Deflections of the structure under the effects of the design serviceability limit state earthquake shall not be such as to cause loss of function.

5.3.7 P-delta effects

An analysis for P-delta effects at the DCLS shall be carried out where either the displacement-based design method, the equivalent static force method or modal response spectrum method of analysis are used unless any one of the following two criteria are satisfied:

- a. the largest translational period based on the initial elastic stiffness of the structure, given by equation (5-9), is less than 0.4 seconds
- b. the height of the structure measured from the point of fixity of its foundation is less than 15m and the largest translational period based on the initial elastic stiffness of the structure is less than 0.6 seconds.

When the numerical integration time history method of analysis is used, P-delta effects shall be incorporated into the analysis for the DCLS.

To avoid the "ratcheting" of structural displacements leading to a large residual displacement and possible instability, the unfactored P-delta moments at the DCLS shall not exceed 25% of the pier-base moment capacity.

5.3.7 continued

For concrete piers, the required seismic design moment at potential plastic hinge locations shall be increased by 50% of the calculated P-delta moment when the P-delta moment exceeds 10% of the pier-base moment capacity.

For steel piers, the required seismic design moment at potential plastic hinge locations shall be increased by 100% of the calculated P-delta moment when the P-delta moment exceeds 5% of the pier-base moment capacity.

The criteria above are presented for plastic hinging at the base of a pier. Similar criteria apply for plastic hinging in other locations (eg in piles or pile-columns).

5.3.8 Distribution of structural mass

a. General

Either a distributed mass model or a lumped mass model may be adopted to represent the distribution of structural mass. For displacement-based analysis the structure's mass is usually modelled as lumped masses at nodes throughout the structural model.

Lumped mass modelling shall comply with the following:

- As a minimum representation of the seismic mass distribution, tributary superstructure mass, including mass of superimposed dead load, mass of pier caps and effective mass of piers shall be combined as a single mass acting on the axis of the pier at the height of the centre of gravity of the combined masses. In this context the effective mass of the piers may be taken as 33% of the total mass of the pier columns or wall (excluding the mass of the pile-cap and pier foundations), with this effective mass positioned at the base of the pier-cap or at the superstructure soffit if there is no pier cap.
- Where the superstructure mass is supported on bearings whose flexibility in the direction considered is such that the superstructure seismic response displacements are expected to significantly exceed pier cap displacements the tributary mass should be represented by a two-mass model separately comprised of the superstructure tributary mass, and the combined pier and pier cap beam mass, separated by a flexible element representing the bearing.
- For bridges with spans longer than 40m and with significant lateral flexibility of superstructure, the superstructure mass distribution should be represented by at least four masses along the length of each span.
- For bridges with tall piers (25 to 40m height) of significant mass, the pier mass distribution should be represented by at least four concentrated sub-masses up the pier height.
- For the analysis of vertical seismic response, the mass of the span under consideration, and of the adjacent spans, if any, should be distributed to not less than four locations along each of the spans.

b. Horizontal torsion

Provision for variation in the seismic effect at supports, due to the centre of resistance and/or the centre of mass of the bridge not being in their calculated horizontal positions need not be considered.

c. Rotational inertia effects

For superstructures supported on single-stem piers with wide hammerheads, the effects of superstructure and hammerhead rotational inertia in generating additional moments in the pier shall be considered, and the additional moments provided for by appropriate detailing.

5.3.9 Member properties for analysis

In calculating natural period, forces and deflections under seismic loading the following values shall be used:

a. Concrete member section properties

For highly-stressed cracked sections (eg piers and piles), the sectional rigidity EI values appropriate to the damage control limit state shall be adopted. Guidance on appropriate values and their application may be found in *Seismic design and retrofit of bridges*⁽⁵⁾, and *Displacement-based seismic design of structures*⁽⁶⁾. The effective elastic sectional rigidity may be determined as outlined in 5.3.4.

For uncracked sections (eg prestressed concrete superstructures), the gross uncracked section value shall be assumed.

b. Sliding bearings

The coefficient of friction to be used for analysis shall be assessed on a conservative basis for the situation being considered. Unless otherwise justified for the specific materials and applications proposed, noting that the coefficient of friction can increase significantly with high velocities, and taking into account deterioration and maintenance requirements over time, 0.02 shall be assumed as the coefficient of friction for situations where a minimum frictional force is appropriate. For situations where a maximum frictional force is appropriate, a coefficient of friction of at least 0.15 shall be used.

c. Variation of material properties

The effects of actual material stiffness properties varying significantly from those assumed for analysis and design shall be taken into account. The likely variation in foundation soil stiffness properties in particular shall be considered. Default limits that should be considered, as a minimum, are 0.5 to 2.0 times the best estimate of soil stiffness, and for concrete 1.0 to 1.3 times the best estimate of the elastic modulus E_c .

5.3.10 Single degree of freedom methods of analysis

Both the equivalent static force method of analysis, based on using the initial tangent stiffness, and the simplified displacement-based design method, based on using the inelastic secant stiffness, as promoted in *Displacement-based seismic design of structures*⁽⁶⁾ are approximate methods of analysis. The equivalent static force method of analysis relies on an assumption that the structure can be appropriately modelled as a single degree of freedom responding structure. The simplified displacement-based design analysis method outlined in 5.4 also makes the same assumption though this is not a general restriction on the method. Structures to which these methods of analysis, assuming single degree of freedom response, may be applied shall exhibit the following features:

- conventional superstructures, eg slab, beam and slab, box girder or truss superstructures
- supported by single column or multi-column or wall piers and/or abutments of reinforced concrete, steel, or segmental precast concrete connected by either bonded or unbonded prestressing
- spans $\leq 100\text{m}$
- pier heights $\leq 40\text{m}$
- subtended angle between the abutments of $\leq 90^\circ$
- concrete strength $f_c' \leq 65\text{ MPa}$.

Structures designed by these methods but meeting the criteria of 5.3.11(a) under which dynamic analysis is recommended shall have their designs confirmed by an appropriate method of dynamic analysis.

5.3.11 Dynamic analysis

Where specified as required, the dynamic analyses procedures described in this section apply to both forced-based and displacement-based design.

a. Criteria under which dynamic analysis is recommended

Dynamic analysis to obtain maximum horizontal forces and displacements or ductility demand, should be carried out where it is not appropriate to represent the structure as a single degree of freedom oscillator. Such cases are:

- i. Bridges where the mass of any pier stem (including any allowance for hydrodynamic effects) is greater than 20% of the mass of that part of the superstructure assumed to contribute to the inertia loading on the pier.
- ii. For transverse analysis, where the bridge or an independent length of bridge between expansion joints has abrupt changes in mass distribution, horizontal stiffness or geometry along its length, or is substantially unsymmetrical.
- iii. Bridges which describe a horizontal arc subtending more than 45°.
- iv. Bridges in which the seismic load resistance is provided by structural systems other than conventional piers and abutments.
- v. Suspension, cable-stayed and arch bridges.
- vi. Bridges with piers designed to rock, for which inelastic time history analysis is preferred (see 5.6.12).

b. General

Consideration shall be given to the regularity of the structure and what directions of seismic attack are likely to yield the greatest demand on the structure. Dynamic analysis shall be undertaken for at least two orthogonal horizontal directions. For horizontally curved bridges one of these directions shall be the chord between the two abutments. Concrete member section properties shall be as defined in 5.3.9(a).

c. Modal response spectrum analysis

Modal response spectrum analysis shall comply with the requirements of NZS 1170.5⁽¹⁾ clause 6.3, as appropriate to the analysis of bridges.

The horizontal design response spectrum, $C_d(T)$, shall be given by:

$$C_d(T) = \frac{C(T)M_\xi}{k_\mu} \quad (5-13)$$

Where:

- $C(T)$ = the elastic site response spectrum determined from 5.2.2 or 5.2.3
- k_μ = the modification factor for ductility, determined as set out in 5.5.3
- M_ξ = the modification factor for damping determined as set out in 5.5.1.

For each direction of earthquake attack considered, the combination of modal action effects shall be carried out using the complete quadratic combination (CQC) technique.

Where the base shear derived from the modal response spectrum analysis is less than the corresponding base shear derived from an equivalent static analysis the design seismic actions and displacements shall be scaled by the ratio of V_e/V where:

- V_e = the base shear found from the equivalent static force method
- V = the base shear found from the modal response spectrum method.

5.3.11 continued

The vertical design response spectrum $C_v(T)$, is the elastic design spectrum as determined from 5.2.3 or 5.2.4 without modification for ductility but modified for damping in accordance with 5.3.3.

In displacement based analysis the horizontal design spectrum is not modified by the ductility reduction factor and effective member stiffnesses at expected maximum displacement demand are used together with appropriate damping levels. Refer to 5.4.1.

d. Numerical integration inelastic time history method

Inelastic time history analysis shall comply with the requirements of NZS 1170.5⁽¹⁾ clause 6.4, as appropriate to inelastic analysis and excluding requirements in respect to inter-storey deflection. Ground motion records shall comply with the requirements of NZS 1170.5⁽¹⁾ clause 5.5. In NZS 1170.5⁽¹⁾ clause 5.5.2(a), S_p shall be taken as 1.0.

In addition, the records shall contain at least 15 seconds of strong ground shaking or have a strong shaking duration of 5 times the fundamental period of the structure, whichever is greater.

Inelastic moment curvature and force displacement idealisations shall be appropriate to the materials being considered and the likely structural performance.

Where soil-structure interaction damping is not included in the modelling of hysteretic damping, the overall damping in the bridge system expressed as a percentage of critical equivalent viscous damping shall take into account both the structural damping and the additional damping arising due to the soil-structure interaction of the foundations.

Hysteretic rules adopted for non-linear time-history shall be appropriate for the materials and sections modelled.

The strain in inelastically deforming elements computed from an inelastic time history analysis and accepted for the design shall not be greater than that permitted by 5.3.5.

5.3.12 Seismic displacements

- a. In displacement-based design determination of the seismic displacement is an inherent component of the design process.
- b. In force based design, where the structural system can be simulated as a single-degree-of-freedom oscillator, the maximum seismic displacement (Δ) of the centre of mass shall be taken from the elastic displacement response spectrum for T_1 in cases where on site subsoil classes A, B, C and D T_1 exceeds 0.7 second or on site subsoil class E T_1 exceeds 1.0 second or calculated as follows, unless a more detailed study is undertaken:

$$\Delta = \frac{\mu C_d(T_1) g T_1^2}{4\pi^2} \quad (5-14)$$

Where:

- Δ = seismic displacement in metres
- T_1 = the fundamental natural period, in seconds
- g = gravity, 9.81m/s²
- $C_d(T_1)$ = as defined in 5.5.3
- μ = as defined in 5.5.2 and figure 5.3.

Where required to be assessed by 5.3.7, displacement due to P-delta effects shall be added to the displacement determined as above.

5.3.12 continued

- c. Where a modal response spectrum analysis is used, displacements derived from the analysis based on the design seismic response spectrum specified in 5.3.11(c) shall be factored by μ .
- d. Where time history analysis is used, displacements may be taken directly from the analysis results.

5.3.13 Coherence of longitudinal seismic response

For bridges longer than 200m in length the effects of spatially varying ground motion may be significant and should be considered in design. There are three main causes of spatial variability:

- the incoherence effect, which represents random differences in the amplitudes and phases of seismic waves due to refractions and reflections of seismic waves during wave propagation from the seismic source
- the wave passage effect which describes the difference in arrival times at different locations
- the site-response effect, which accounts for the differences in the surface motion caused by variable soil profiles at the foundations of the piers and abutments.

The solution of the equations of motion of a multi-degree-of-freedom structure subjected to variable input motions at its supports can be separated into a pseudo-static part produced by the static differential displacements at the restrained joints and a dynamic part produced by the dynamic response of the structure.

A pseudostatic response analysis shall be carried out for bridges longer than 200m by estimating the non-synchronous displacements at the pier and abutment locations. The maximum longitudinal differential displacement can be estimated by:

$$\Delta_m = V_m \frac{L}{2V_a} \quad (5-15)$$

Where:

V_m = the peak ground velocity (PGV),

L = the distance between the foundation locations

V_a = the apparent wave speed between the foundation locations.

The transverse differential displacements can be estimated from:

$$K_g = \frac{A_m}{V_a^2} \quad (5-16)$$

Where:

K_g = the maximum ground curvature

A_m = the peak ground acceleration (PGA).

The PGV for a specific site and earthquake event can be estimated using ground motion prediction equations (GMPEs). However, there is a moderately strong correlation between PGA and PGV allowing the PGV to be estimated with sufficient accuracy for this application from the PGA specified for the design ground motion. The ratio of PGV in m/s to PGA in g units is approximately 1.0 for soil category classification A and B (rock), 1.3 for soil category C (intermediate soils) and 1.7 for soil category D (soft and deep soils).

5.3.13 continued

The apparent wave velocity between the foundation points is influenced by the wave propagation speeds in the underlying strata as well as the shear wave velocity in the upper layers. Surface waves may also have a significant influence on the apparent wave velocity. A value of 1,000m/s is recommended for design ground displacement and curvature estimates. This relatively low value will give an upper bound to the relative displacements between the foundation locations.

For bridge frames longer than 400m a direct numerical integration analysis using displacement input motions varying between the support points should be performed to obtain the dynamic part of the displacement of the structure displacement solution. Ground displacement time histories for the support points along the length may be estimated using simplified procedures suggested in *Seismic design and retrofit of bridges*⁽⁵⁾. For bridge frames less than 400m in length the dynamic component can be estimated assuming uniform input motions at the support locations unless the local ground conditions vary significantly over the length. For bridge frames longer than 200m and where the local ground conditions vary significantly a numerical integration analysis should be carried out or an average response spectrum based on the different ground conditions used (see *Seismic design and retrofit of bridges*⁽⁵⁾).

Pseudostatic and dynamic displacement components should be combined using the square root of the sum of the squares (SRSS) rule.

Because of the difficulties in adequately representing the influence of ground conditions along the bridge together with uncertainties related to the lack of coherence and synchronism of the input ground motions at the piers it is recommended that bridges longer than 200m be subdivided into frames extending between movement joints in the superstructure or between abutments and movement joints. Each frame can be considered to respond independently of the rest of the bridge with the input spectrum (or time histories) based on the local soil conditions for each frame. Where the frames have no interconnection the relative displacement between them can be estimated using the displacement based design method. For frames interconnected by linkages or restrainers, the charts presented in *Seismic design and retrofit of bridges*⁽⁵⁾ and *Performance of linkage bars for restraint of bridge spans in earthquakes*⁽¹⁷⁾ can be used to make predictions of the relative movements and linkage forces.

(Equation (5-15) and its application to bridge analysis is presented in *Seismic design and retrofit of bridges*⁽⁵⁾. Background information on both equations (5-15) and (5-16) and the apparent wave speed parameter is given in *Seismic design of buried and offshore pipelines*⁽¹⁸⁾. A detailed derivation of the equations is given in *Problems in wave propagation in soil and rocks*⁽¹⁹⁾.)

5.4 Displacement-based analysis methods

5.4.1 General

Displacement-based design based on using the inelastic secant stiffness as promoted in *Displacement-based seismic design of structures*⁽⁶⁾ provides an alternative approach to the force-based approach in determining earthquake actions for bridges. For design and construct type projects, where the lateral load resisting elements are designed to be ductile or to possess limited ductility, displacement-based design shall be adopted unless other methods are specified in the principal's (or minimum) requirements for the project or are otherwise agreed to by the road controlling authority. Seismicity is represented by displacement, rather than acceleration spectra, and is completely compatible with the seismic hazard as defined in 5.2.

Strength requirements for seismic resistance are based on strain limits defined for the damage control limit state. Strength so determined is taken to be adequate for the serviceability limit state and for the collapse avoidance limit states provided that there is no change in the mode of structural behaviour under seismic loading greater than the DCLS event and that there are no additional loads applied to the structure during seismic response, eg due to soil lateral spread.

The final design of all bridge structures of importance level 4 and of all bridges with significant irregularity of structural form resulting from high horizontal curvature and/or adjacent piers of significant difference in stiffness, should be verified by modal response spectrum analysis using effective member stiffness at expected maximum displacement demand together with appropriate damping levels, or non-linear time-history analysis, in accordance with 5.3.11. The selection of earthquake records for time history analysis shall comply with 5.3.11(d). (Use of modal analysis requires substitute structure modelling. Refer to *Seismic design and retrofit of bridges*⁽⁵⁾ sections 4.4.3 and 4.5.2(b) for guidance on undertaking this.)

For a bridge to be considered to be regular it shall satisfy the requirements of the *AASHTO Guide specifications for LRFD seismic bridge design*⁽²⁰⁾, table 4.2-3 and should also satisfy the relative stiffness between bridge elements requirements of clauses 4.1.2 and 4.1.3 of the *Guide specifications for LRFD seismic bridge design*⁽²⁰⁾.

The procedure for displacement-based earthquake design will generally proceed in accordance with the following steps. However, when it is obvious that specific seismic design will be required, steps (iii) to (vi) may be omitted.

- i. Determine the site seismicity in terms of the elastic design displacement spectrum.
- ii. Determine the yield displacements of all piers.
- iii. Check whether yield displacements exceed the elastic corner-period displacement of the elastic design displacement spectrum. If so, standard detailing of the load resisting members appropriate to an elastically responding structure in accordance with this manual and the referenced materials standard will be adequate subject to the requirements of strength, ductility (if mobilised) and stability under response to the CALS event being confirmed.
- iv. If the check in step (iii) fails, determine the fundamental period of bridge in the direction considered.
- v. Determine elastic displacement response at fundamental period.
- vi. Check whether yield displacements exceed the displacement requirements of the elastic design displacement spectrum for fundamental period. If so, standard detailing of the load resisting members in accordance with this manual and the referenced materials standard will be adequate, subject to the requirements of strength and stability under response to the CALS event being confirmed.

5.4.1 continued

- vii. If ductile earthquake design is indicated by the above steps, carry out displacement-based earthquake design, in accordance with the following provisions, to determine required lateral strength of piers and abutments.

More complete information on the procedure is available in *Displacement-based seismic design of structures*⁽⁶⁾.

5.4.2 Reduced design displacement spectrum for ductile response

The equivalent viscous damping ξ_e for the bridge or bridge sub-frame, corresponding to the design ductility level of response (SLS, DCLS or CALS) shall be calculated in accordance with 5.4.3(f). Allowance shall be made for elastic and hysteretic damping associated with pier ductility, superstructure flexure, foundation flexibility and abutment displacement, as appropriate, in accordance with 5.4.3(g).

The reduced design displacement spectrum $\Delta_d(T)$ for ductile response shall be found by multiplying the elastic displacement spectrum given by equation (5-4) by the damping modifier M_ξ defined by equation (5-17).

$$M_\xi = \left(\frac{0.07}{0.02 + \xi_e} \right)^\alpha \quad (5-17)$$

Where:

α = 0.25 for near-field situations, within 10km of a major active fault shown in NZS 1170.5⁽¹⁾ figure 3.5 or of faults with a recurrence interval of less than 2000 years; or

= 0.5 for all other situations

ξ_e = equivalent viscous damping ratio, given in equation (5-23).

Thus the design displacement

$$\Delta_d(T) = M_\xi RZN(T, D)\Delta_h(T) \quad (5-18)$$

Where:

R shall be taken as $\frac{R_u}{4}$ for the SLS, R_u for the DCLS and $1.5R_u$ for the CALS.

Z , $N(T, D)$ and $\Delta_h(T)$ are as given in 5.2.4(b).

5.4.3 Seismic analysis for design strength of plastic hinges

a. Design lateral earthquake force

The design lateral earthquake forces shall be determined in accordance with the provisions of this section.

The design lateral earthquake force, F_F , for a bridge frame shall be determined from equation (5-19):

$$F_F = k_e \Delta_d \quad (5-19)$$

Where:

Δ_d = the characteristic design displacement of the frame, defined in 5.4.3(b)

k_e = the effective stiffness of the frame, defined in 5.4.3(d).

Abutment design lateral forces shall be calculated in accordance with 5.4.8.

b. Frame characteristic design displacement

The characteristic design displacement of the frame is defined by equation (5-20):

$$\Delta_d = \frac{\sum_{i=1}^n (m_i \Delta_i^2)}{\sum_{i=1}^n (m_i \Delta_i)} \quad (5-20)$$

5.4.3 continued

Where:

Δ_i = design displacements of the n masses describing the frame given in 5.4.4

m_i = the masses at the n mass locations describing the frame.

c. Frame effective stiffness

The frame effective stiffness is defined by equation (5-21):

$$k_e = \frac{4\pi^2 m_e}{T_e^2} \quad (5-21)$$

Where:

T_e = period, defined in 5.4.3(e)

m_e = the effective mass of the frame defined in 5.4.3(d).

d. Frame effective mass

The frame effective mass is defined by equation (5-22):

$$m_e = \frac{\sum_{i=1}^n (m_i \Delta_i)}{\Delta_d} \quad (5-22)$$

Where:

Δ_d = the characteristic design displacement defined by equation (5-20).

e. Frame effective period

The frame effective period (T_e) at DCLS displacement response is found from the displacement spectra defined in equation (5-18) corresponding to the characteristic design displacement defined by equation (5-20), and the calculated equivalent viscous damping defined in 5.4.3(f).

f. Frame equivalent viscous damping ratio

The frame equivalent viscous damping ratio shall be related to the shear force (V_i), the displacement (Δ_i), and the damping ratios (ξ_i) of the structural components (piers, abutments, superstructure, foundations, bearings) of the frame according to equation (5-23):

$$\xi_e = \frac{\sum_{i=1}^n (V_i \Delta_i \xi_i)}{\sum_{i=1}^n (V_i \Delta_i)} \quad (5-23)$$

Where:

V_i = shear force in structural components of the frame at design response

Δ_i = design displacement of structural components of the frame (5.4.4)

ξ_i = damping of structural components of the frame given in 5.4.3(g).

g. Equivalent viscous damping ratio of component actions

Within this sub-clause (g) μ_m is the member displacement ductility assessed over the member height or length.

i. Reinforced concrete piers

The equivalent viscous damping ratio of reinforced concrete piers shall be related to the pier member displacement ductility (μ_m) by equation (5-24):

$$\xi_i = 0.05 + 0.444 \left(\frac{\mu_m - 1}{\mu_m \pi} \right) \quad (5-24)$$

5.4.3 continued

ii. Structural steel piers

The equivalent viscous damping ratio of structural steel piers shall be related to the pier member displacement ductility (μ_m) by equation (5-25):

$$\xi_i = 0.02 + 0.577 \left(\frac{\mu_m - 1}{\mu_m \pi} \right) \quad (5-25)$$

iii. Foundation rotation effect

In lieu of more accurate determination, the equivalent viscous damping associated with rotation of spread footings on dense sand and alluvium of greater than $\theta=0.00182$ or on medium-dense sand greater than $\theta=0.00172$ shall be given by equation (5-26) and (5-27) respectively. For rotations less than these values of θ a value of $\xi_i=0.05$ may be used.

For dense sand and alluvium: $\xi_i = 0.365 + 0.115 \log_{10} \theta \quad (5-26)$

For medium dense sand: $\xi_i = 0.52 + 0.17 \log_{10} \theta \quad (5-27)$

Where:

θ = the foundation rotation in radians.

For foundations on rock of essentially zero deformation no additional damping shall be assumed and the equivalent viscous damping shall be taken as $\xi_i=0.05$.

iv. Superstructure transverse flexural deformation

When a reinforced concrete superstructure is subjected to lateral deformation involving abutment reactions without significant abutment displacement, the superstructure damping ratio shall be taken as $\xi_i=0.05$. The value to be taken for prestressed concrete or structural steel superstructure shall be 0.03 and 0.02 respectively.

v. Abutment deformation

The equivalent viscous damping ratio associated with soil deformation at an abutment will depend on the abutment soil material and shear strain.

For abutment foundations, not supported by piles, and where significant sliding on the ground occurs $\xi_i=0.25$. For abutments not supported on piles and fitted with a friction slab $\xi_i = 0.30$.

Where the abutment is supported by piles, behaviour is further complicated. In lieu of a more accurate determination, a conservatively low value of $\xi_i=0.12$ may be adopted for analysis. If the piled abutment is fitted with a friction slab a value of $\xi_i = 0.25$ may be used.

vi. Bearings

- o Elastomeric bearings: In lieu of specific manufacturers' data, use $\xi_i=0.05$
- o Friction slider bearings: In lieu of specific manufacturers' data use:

$$\xi_i = 0.05 + 0.67 \left(\frac{\mu_m - 1}{\mu_m \pi} \right) \quad (5-28)$$

- o Elastomeric bearings in conjunction with lead plug: use manufacturers' data
- o Steel damping elements: use equation (5-25)
- o Friction pendulum bearings: use manufacturers' data.

vii. Piled foundations where hinges develop in piles

$$\xi_i = 0.10 + 0.565 \left(\frac{\mu_m - 1}{\mu_m \pi} \right) \quad (5-29)$$

5.4.3 continued

viii. Pile/column designs

In lieu of detailed studies the following conservative values may be used.

- o Column fixed to superstructure:

$$\text{Sand: } \xi_i = 0.075 + 0.03(\mu_m - 1) \leq 0.135 \quad (5-30)$$

$$\text{Clay: } \xi_i = 0.12 + 0.03(\mu_m - 1) \leq 0.18 \quad (5-31)$$

- o Column pinned to superstructure:

$$\text{Sand: } \xi_i = 0.10 + 0.04(\mu_m - 1) \leq 0.18 \quad (5-32)$$

$$\text{Clay: } \xi_i = 0.15 + 0.04(\mu_m - 1) \leq 0.23 \quad (5-33)$$

ix. Friction slabs

A conservative value of $\xi_i=0.25$ may be used, independent of displacement level.

- x. Segmental piers connected by un-bonded post-tensioning

$$\xi_i=0.05$$

- xi. Segmental piers connected by bonded post-tensioning

$\xi_i=0.05$, provided tendon strain does not exceed the limit of proportionality.

5.4.4 Design displacement profile

The design displacement profile (Δ_i) shall be related to the normalized fundamental displacement mode shape (δ_i) scaled to fit the displacement capacity (Δ_c) of the critical inelastic structural element, measured at the appropriate mass location by the relationship:

$$\Delta_i = \delta_i \left(\frac{\Delta_c}{\delta_c} \right) \quad (5-34)$$

Where:

δ_i = the normalized fundamental displacement mode shape at location i

δ_c = value of the normalized fundamental displacement mode shape at the critical location c

Δ_c = design displacement capacity of the critical inelastic structural element at location c.

In equation (5-34), the displacement capacities of inelastic structural elements shall be based on the strain limits defined in 5.3.5, and shall include effects of foundation and bearing flexibility, where appropriate.

5.4.5 Displacement capacity of piers

The structural component of displacement capacity of a pier corresponding to the damage control limit state depends on the plastic hinge length (L_p) the limit state strains in the plastic hinge (5.3.5) and the pier height (H) and may be calculated from equation (5-35):

$$\Delta_u = \Delta_y + \Delta_p \quad (5-35)$$

where Δ_y is given by equation (5-10), and the plastic displacement is given by

$$\Delta_p = (\phi_u - \phi_y)L_p H \quad (5-36)$$

and the plastic hinge length is given by

$$L_p = k_{tp}H_c + L_{sp} \geq 2L_{sp} \quad (5-37)$$

5.4.5 continued

Where:

$$k_{lp} = 0.2 \left(\frac{f_u}{f_y} - 1 \right) \leq 0.08 \quad (5-38)$$

In equation (5-36), ϕ_u is the lesser of the damage control curvatures corresponding to the limit state strains defined in 5.3.5, ϕ_y is the yield curvature given by equation (5-8), and H is the height of the pier between critical sections of the plastic hinges at top and bottom of the pier (pier in double bending), or the height from the critical section of the plastic hinge to the point of contraflexure at top or bottom of the pier.

In equation (5-37), L_{sp} is the strain penetration length defined in 5.3.4(b) and H_c is the distance from the critical section of the plastic hinge to the point of contraflexure in the pier.

In equation (5-38), f_u and f_y are the ultimate and yield strengths of the pier flexural reinforcement. For reinforcing steel sourced from Pacific Steel, default values for f_u/f_y of $f_u/f_y = 1.2$ for grade 500E and $f_u/f_y = 1.4$ for grade 300E reinforcing steel may be adopted. For reinforcing steel from other sources the ratio of f_u/f_y shall be established from representative data obtained from the manufacturer.

In the case of pile-columns of constant cross-section, plastic rotation shall be assumed to occur at the level of maximum moment in the pile with the plastic hinge length taken to be $L_p = D + 0.1H_c \leq 1.6D$ where H_c in this case is the height from the ground surface to the point of contraflexure in the pier above the ground surface. In the case of pile columns with a fixed connection to the superstructure design will generally be governed by the column top hinge for which L_p shall be taken to be as defined by equation (5-37). (For further guidance in respect to the pile-column case refer to *Displacement-based seismic design of structures*⁽⁶⁾ section 10.3 and in particular, the design examples of 10.3.5. This guidance includes methods for determining the depth of the plastic hinge forming in the ground and the C_1 coefficient in equation (5-10) for estimating the yield displacement.)

5.4.6 Distribution of design lateral force

The lateral design force F_F given by equation (5-19) shall be distributed to the n frame mass locations m_i in accordance with equation (5-39):

$$F_i = F_F \frac{m_i \Delta_i}{\sum_{i=1}^n m_i \Delta_i} \quad (5-39)$$

5.4.7 Design seismic moments in potential plastic hinges

Design seismic moments in potential plastic hinge regions of a frame shall be determined from the lateral frame forces (F_i) using accepted methods of structural analysis, and shall include consideration of P-delta moments in accordance with 5.3.7. Stiffness of ductile elements shall be based on the secant stiffness at the design displacement (Δ_i).

5.4.8 Design abutment forces

Design abutment reactions shall be determined by one of the following approaches:

- a. Where initial analysis indicates that elastic response of the frame is assured at the DCLS, design abutment forces may be determined by a static analysis using an assumed first-mode shape or an elastic modal analysis for both the DCLS and the CALS event (ie an event corresponding to a return period factor of $1.5R_u$).
- b. Where ductile response is adopted for design in accordance with 5.4.1, the abutment forces shall be determined by one of the following procedures:
 - Forces determined by effective modal superposition under the design seismicity, where the stiffness of ductile elements is the secant stiffness at design displacement response and the global damping ratio used in the analysis is the system damping determined in the displacement-based design (equation (5-23)).
 - Inelastic time history analysis under the design seismicity.

5.5 Force based analysis methods

5.5.1 Elastic response spectrum reduction due to foundation damping

Equivalent viscous damping associated with soil structure interaction may be taken into account to reduce the design seismic response spectrum by undertaking an initial seismic analysis using the elastic response spectrum to derive the relative shears and displacements for the above ground structure and the relative foundation shears and displacements; and then by applying the procedures of 5.4.3(f) to derive the equivalent combined structural and soil-structure interaction damping ratio associated with the whole structure, followed by equation (5-17), to derive the damping modifier (M_ξ). The damping modifier may then be applied to factor down the elastic response spectrum prior to applying the procedures of 5.5.2 to derive the modified elastic response spectrum. The damping modifier (M_ξ) shall not be taken to be less than 0.7.

The equivalent viscous damping ratios for the various foundation elements may be conservatively assumed as follows:

- spread footings founded on dense sand or alluvium, or medium dense sand:

Dense sand and alluvium	Rotation > 0.00182 radians $\xi_i = 0.365 + 0.115 \log_{10} \theta$	Rotation \leq 0.00182 radians $\xi_i = 0.050$
Medium-dense sand	Rotation > 0.00172 radians $\xi_i = 0.52 + 0.17 \log_{10} \theta$	Rotation \leq 0.00172 radians $\xi_i = 0.050$

Where:

θ = the foundation rotation in radians.

- spread footings founded on rock of essentially zero deformation: $\xi_i=0.05$
- pier pile foundations in sands and granular material: $\xi_i=0.10$
- pier pile foundations in clay: $\xi_i=0.15$
- abutments supported on piles: $\xi_i=0.12$
- abutments, unsupported by piles, and with friction slabs sliding on ground: $\xi_i=0.25$.

For above ground structural elements the equivalent viscous damping ratios may be taken as:

- reinforced concrete elements: $\xi_i=0.05$
- prestressed concrete elements: $\xi_i=0.03$
- steel elements: $\xi_i=0.02$.

5.5.2 Modified elastic response spectrum reduction due to ductility

The structure displacement ductility factor (μ) is defined as the design displacement of the centre of mass under DCLS earthquake response divided by the displacement at yield, as illustrated in figure 5.3, which also illustrates the nature of the force/displacement relationship for structures exhibiting various categories of behaviour.

In figure 5.3, the design force H is the design force derived by the procedures specified by 5.2 and this section, 5.5, including the modifications for ductility and foundation damping. For the flexural design of plastic hinges, the strength reduction factor (ϕ) is taken as 1.0.

Figure 5.3: Idealised force/displacement relationships for various structural categories

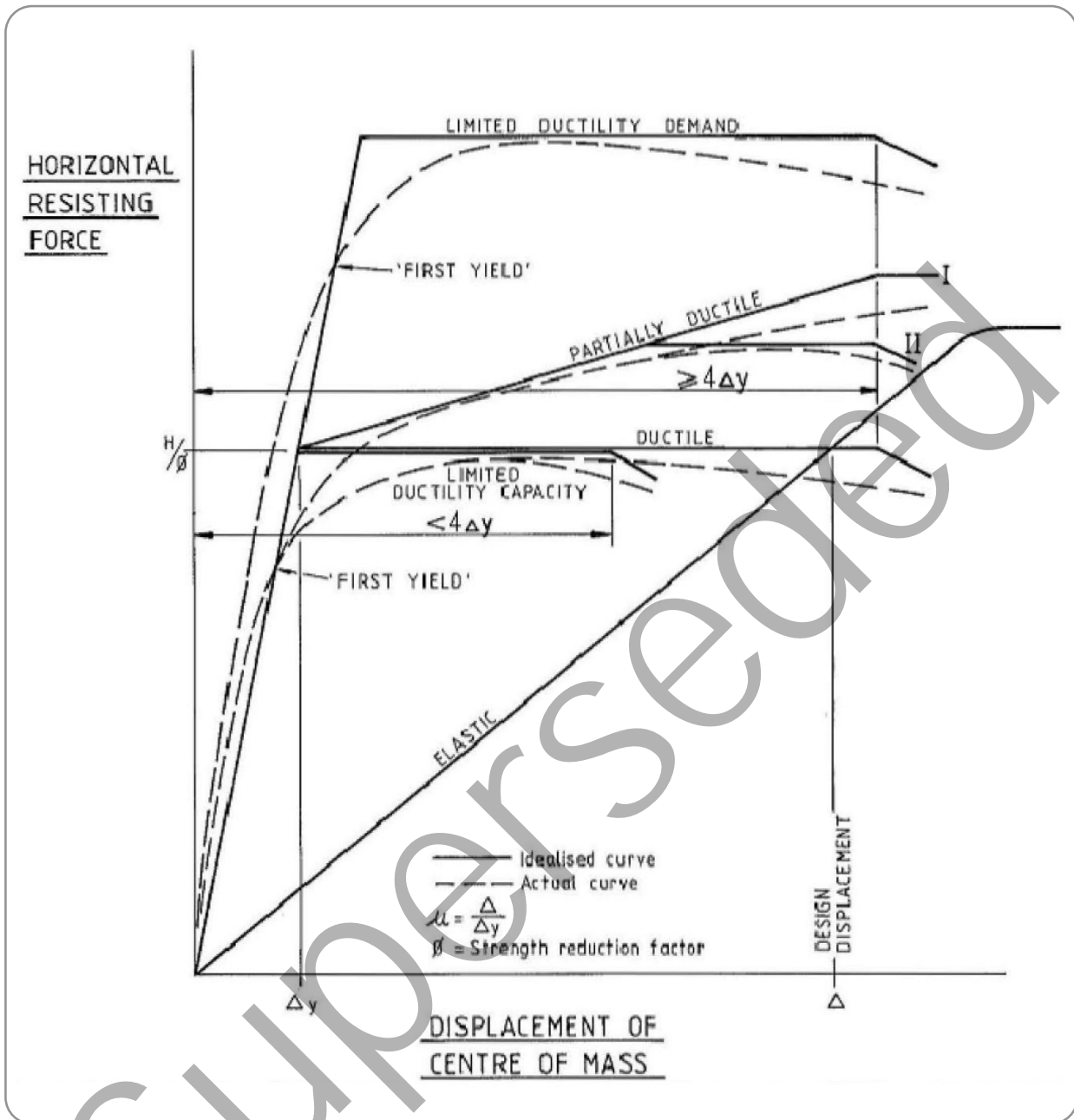

5.5.2 continued

For equivalent static force analysis and modal response spectrum analysis, ductility shall be taken into account to derive the design inelastic response spectrum from the site elastic hazard spectrum modified for foundation damping as set out in 5.5.3. The maximum allowable values of μ for various structural forms that may be adopted are listed in table 5.6, and examples for some of the structural forms are shown diagrammatically in figure 5.4. Force-based design is based on assuming a ductility demand at the outset of design. In all cases, the designer shall check the actual ductility demand that will be imposed on their structure by the design actions and ensure that the structure as detailed satisfies the maximum allowable value of μ for its form and is capable of sustaining the actual ductility demand, and that any plastic hinge section curvature ductility limitations imposed by the strain limits specified by 5.3.5 are satisfied.

5.5.2 continued

In the context of table 5.6, ductile, partially ductile and elastic structures are as defined in 5.6.4, 5.6.5 and 5.6.6 respectively. A structure on spread footings designed to rock is as defined in 5.6.12, and a locked-in structure is as defined in 5.6.8.

For cantilever columns on flexible foundations, the displacement due to the foundation shall be assessed as the displacement at the base of the column base plastic hinge plus the displacement due to rotation and displacement in the foundation at the level of the base of the plastic hinge projected up to the level of the centre of mass (ie the centre of the seismic inertia).

The structure displacement ductility factors for response in the longitudinal direction and in the transverse direction need not necessarily be the same value.

Table 5.6: Design displacement ductility factor (μ) - maximum allowable values

Energy dissipations system / structural form	μ
<ul style="list-style-type: none"> Structures with ductile frame type piers in which plastic hinges form in the columns at design load intensity in reasonably accessible positions, eg less than 2m below ground but not below normal (or mean tide) water level to form a complete mechanism Monolithic ductile pier (column or wall) - superstructure designs in which plastic hinges form at design load intensity in reasonably accessible positions Structures with ductile cantilever columns or walls pinned to the superstructure in which plastic hinges form in reasonably accessible positions and where the foundations contribute less than 30% of the yield displacement 	4.0
<ul style="list-style-type: none"> All of the above types of structures in which plastic hinges are inaccessible, forming more than 2m below ground or below normal (or mean tide) water level, or at a design level that is not reasonably predictable. Partially ductile structures (types I and II) Structures with ductile cantilever columns pinned to the superstructure in which plastic hinges form and where the foundations contribute more than 30% of the yield displacement 	3.0
<ul style="list-style-type: none"> Structures with ductile pile-column piers (ie the pier is composed of continuous pile-column elements of constant cross-section) where plastic hinges form in the pile elements. 	2.5
<ul style="list-style-type: none"> Structures where plastic hinges form in ductile hollow columns Structures where the earthquake resistance is provided predominantly by ductile vertical piles at the abutments. Single span portal frame with ductile walls 	2.0
<ul style="list-style-type: none"> Structures where piers or abutments are supported on raked piles designed to resist the earthquake loads and where plastic hinges do not form in the columns. 	1.25
<ul style="list-style-type: none"> Structures with piers supported on spread footings expected to rock "Locked-in" structure with abutments founded on spread footings Elastically responding structure Superstructures subjected to vertical response 	1.0

Figure 5.4: Examples of maximum values of μ allowed by table 5.6 for the DCLS

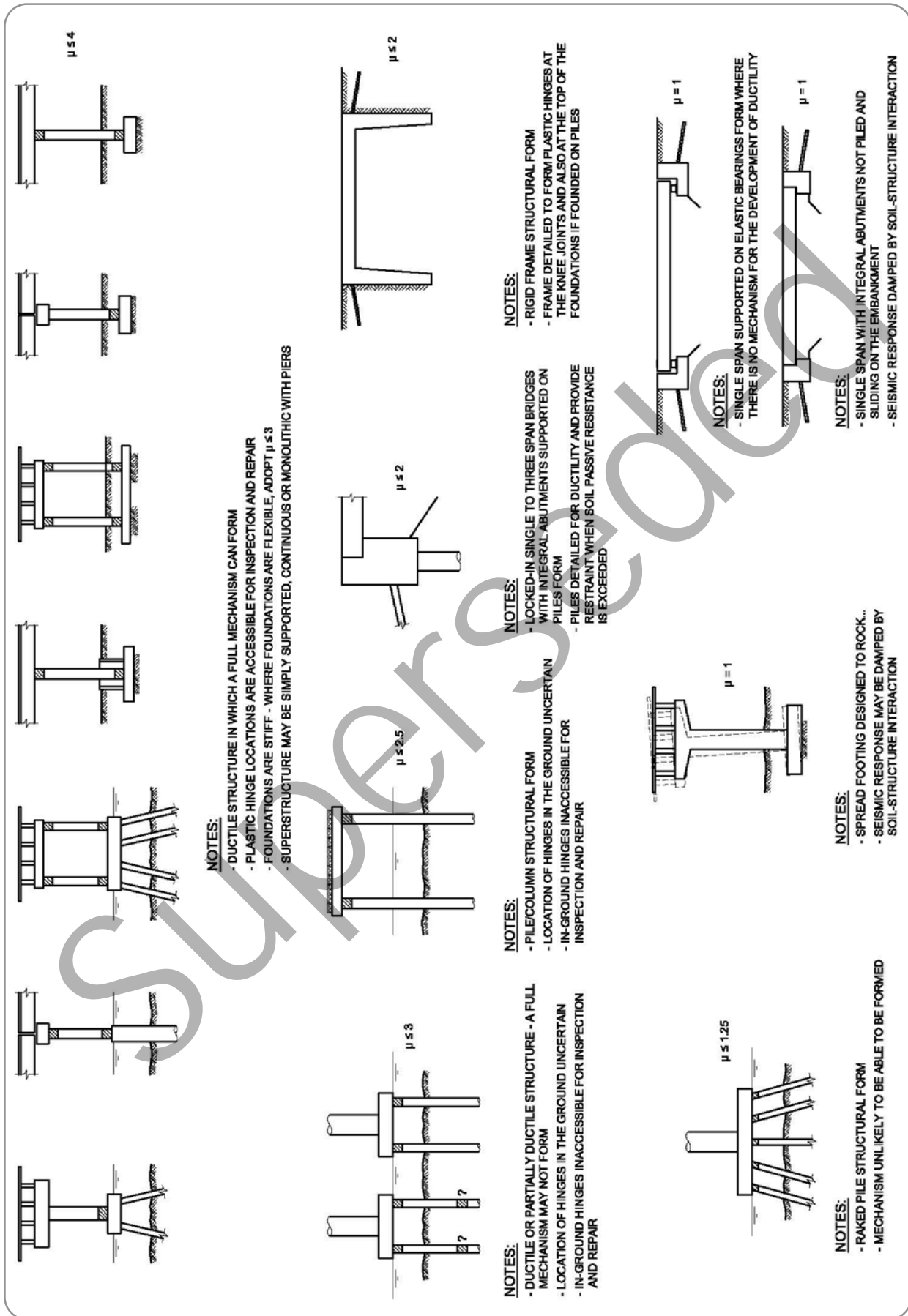

5.5.3 Equivalent static force method of analysis

For a structure represented as a single-degree-of-freedom oscillator, the minimum horizontal seismic base shear force (V) for the direction being considered, shall be calculated as:

$$V = C_d(T_1)W_t \quad (5-40)$$

Where:

$C_d(T_1)$ = horizontal design action coefficient, determined as set out below

W_t = total dead weight plus superimposed dead weight (force units) assumed to participate in seismic movements in the direction being considered.

The horizontal design action coefficient ($C_d(T_1)$) shall be:

$$C_d(T_1) = \frac{C(T_1)M_\xi}{k_\mu} \quad (5-41)$$

For the damage control limit state, $C_d(T_1)$ shall satisfy the following:

$$C_d(T_1) \geq \left(\frac{Z}{20} + 0.02\right)R_u \quad \text{but not less than } 0.03R_u \quad (5-42)$$

Where:

$C(T_1)$ = the ordinate of the elastic site hazard spectrum determined from 5.2.2 or 5.2.5, for the fundamental translational period of vibration

T_1 = the fundamental translational period of vibration

Z = the hazard factor, determined from 5.2.2(a) and NZS 1170.5⁽¹⁾ clause 3.1.4

R_u = DCLS return period from 5.2.2(b)

M_ξ = the modification factor for foundation damping determined as set out in 5.5.1

k_μ = the modification factor for ductility, determined as follows:

For soil Classes A, B, C and D as defined by NZS 1170.5⁽¹⁾ clause 3.1.3:

$$k_\mu = \mu \quad \text{for } T_1 \geq 0.7 \text{ seconds} \quad (5-43)$$

$$k_\mu = \frac{(\mu - 1)T_1}{0.7} + 1 \quad \text{for } T_1 < 0.7 \text{ seconds} \quad (5-44)$$

For soil Class E as defined by NZS 1170.5⁽¹⁾ clause 3.1.3:

$$k_\mu = \mu \quad \text{for } T_1 \geq 1.0 \text{ seconds or } \mu < 1.5 \quad (5-45)$$

$$k_\mu = (\mu - 1.5)T_1 + 1.5 \quad \text{for } T_1 < 1.0 \text{ seconds and } \mu \geq 1.5 \quad (5-46)$$

provided that for the purpose of calculating k_μ , for all soil types, T_1 shall not be taken less than 0.4 seconds.

The vertical design response spectrum $C_v(T)$, is the elastic design spectrum as determined from 5.2.3 or 5.2.4 modified for damping in accordance with 5.3.3 but without modification for ductility.

5.6 Member design criteria and foundation design

5.6.1 Capacity design

The principles of capacity design apply to both displacement-based design and force-based design and shall be applied to the design of ductile structures and structures of limited ductility as defined by 5.6.4(a). These principles are:

- a. That elements of the structure intended to dissipate seismic energy through plastic deformation be designed to possess sufficient strength to withstand the design action, and to maintain their structural integrity sufficient to develop the necessary ductility without undue loss of strength.
- b. That other elements and members of the structure, intended to remain elastic during earthquake response, be designed to withstand the forces induced in them through the plastically deforming elements developing their overstrength capacity under response of the structure to strong earthquake motions.

Plastically deforming elements will commonly be plastic hinge zones designed to form at the base and possibly also at the top of columns. However, they also include base isolation devices incorporating mechanical energy dissipation. Development of overstrength in these elements can arise through actual material strengths being greater than assumed in design and through the strain hardening of steel as it is strained plastically. For concrete plastic hinge locations, the overstrength capacity should be determined by moment curvature analysis using the probable ultimate material strengths given in column (2) of table 5.7 and with strain hardening of the flexural steel also allowed for in the analysis.

For wall or single column type piers, where simple analyses that do not take into account strain hardening of the reinforcement are used in lieu of a detailed analysis, using material strengths in accordance with table 5.7, column (2), the flexural overstrength capacity at the plastic hinge locations may be assumed to be 1.5 times the design strength where grade 500E reinforcement is used, and 1.7 times the design strength where grade 300E reinforcement is used.

For a bent containing multiple columns, the axial load in the columns will vary under seismic response acting in the plane of the bent, and this shall be taken into account in assessing the maximum moment capacity of the plastic hinges to be considered in determining the overstrength actions to be catered for.

In the strength design of elements and members intended to remain elastic, and of plastically deforming elements for modes of action other than that of the intended plastic action, shear failure and the formation of unintended plastic hinges shall be avoided.

Where either:

- simple methods of section analysis are used (eg *Gen-Col*⁽²¹⁾), or
- the moment curvature method of section analysis, incorporating reinforcement strain hardening

is used for the DCLS level of earthquake response, the dependable strength of capacity protected actions and locations shall be determined using conservative estimates of material strength in accordance with table 5.7, column (3) and standard strength-reduction factors (eg strength reduction factors of less than 1.0 as specified for reinforced concrete by NZS 3101⁽²⁾ clause 2.3.2.2 or for structural steel as specified by NZS 3404:1997⁽³⁾ table 3.3 or AS/NZS 5100.6 *Bridge design* part 6 Steel and composite construction⁽²²⁾ table 3.2). For concrete sections, the flexural strength should be determined at the extreme fibre compression strain of 0.004 or a reinforcement strain of 0.015, whichever occurs first. The capacity design of foundations shall comply with 6.5.4 and 6.5.5.

5.6.1 continued

As required by 5.1.3, where the mode of behaviour of the structure changes, or loading conditions acting on the structure change, from that applying at the DCLS in events greater the DCLS event, the avoidance of brittle failure and/or formation of unintended plastic hinges under levels of earthquake response up to the CALS shall be ensured. For this a moment-curvature analysis shall be undertaken of the plastic hinge overstrength capacity at the CALS level of plastic hinge curvature and reinforcement strain hardening. Material strengths as applied for design at the DCLS but less conservative strength reduction factors of $\phi=1.0$ for flexure and axial load and $\phi=0.9$ for shear and torsion shall be adopted in assessing the capacity of the capacity protected members and elements to withstand the CALS overstrength actions.

Since there is uncertainty regarding the strength and stiffness properties of the foundation soil or rock, and in the contribution of the soil or rock to either increased loads or increased resistance depending on the case, upper bound and lower bound properties shall be determined and used to assess the performance of the structure, as required by 5.3.9(c), with the most critical combinations of actions and levels of resistance used in the capacity design of the structure. (Refer also to 5.3.9(c).)

5.6.2 Required flexural and axial load capacity for seismic and other actions

a. Non-seismic and vertical seismic response load cases

The structural members, including critical ductile elements, shall be designed, using characteristic material strengths and with the normal strength reduction factors applied, with at least sufficient capacity to resist the factored action demands due to all non-seismic load cases and the vertical seismic response load case. The critical force actions shall be determined from consideration of how they will initially exist prior to any earthquake response resulting in inelastic behaviour, and also from making allowance for the redistribution of permanent load moments arising from any plastic deformation in the critical ductile elements under horizontal seismic loading.

b. Seismic load case

i. At potential plastic hinge locations

The critical ductile elements shall be designed for the following DCLS concurrent actions:

- horizontal seismic response moments or displacement demands (including P-delta effects determined in accordance with 5.3.7)
- horizontal seismic response axial forces
- permanent load axial forces.

Vertical seismic response and permanent load moments need not be combined with horizontal seismic response moments and may be ignored. Axial forces due to horizontal seismic response are to be added to the permanent load axial load effects. Where axial loads arise from soil or water permanent actions, the load factor to be applied to those axial loads shall be taken as 1.0. (Note 5.3.5. While at plastic hinges the moments due to permanent loads may be neglected in the design of the plastic hinge flexural capacity, the strains due to permanent load moments must be taken into account.)

The moment capacity at plastic hinge locations for DCLS horizontal seismic response actions shall be determined using probable material strengths (f'_{ce} , f_{sye} and f_{ye}) in accordance with table 5.7, column (1).

5.6.2 continued

It is recommended that section design of plastic hinges be undertaken using moment-curvature analysis that includes modelling of strain hardening of the reinforcement to achieve a more economical reinforcement design than will be achieved by conventional section design and estimated overstrength capacity demands. (Refer to *Displacement-based seismic design of structures*⁽⁶⁾, section 4.5.1, for a design example.)

Flexural strength reduction factors need not be used for determination of seismic moment capacity. The moment capacity, taking into account concurrent axial load effects, shall not be less than the moment demand (including the associated P-delta effects) imposed by horizontal earthquake response determined from analyses in accordance with 5.4 or 5.5.

Table 5.7: Material strengths to be used in seismic design

	Probable (expected) material strength for plastic hinge zone design level flexural capacity (1)	Maximum feasible material strength for plastic hinge zone overstrength capacity evaluation (2)	Material strength for capacity design of non-hinging zones and plastic hinge shear capacity (3)
Concrete compressive strength	$f'_{ce} = 1.3f'_c$	$f'^{\circ}_c = 1.7f'_c$	f'_c
Flexural reinforcement	$f_{sye} = 1.1f_y$	$f_{sy}^{\circ} = 1.25f_y$	f_y
Transverse reinforcement	$f_{sy.te} = f_{sy.t}$	$f_{sy.t}^{\circ} = f_{sy.t}$	$f_{sy.t}$
Structural steel	$f_{ye} = 1.1f_y$	$f_y^{\circ} = 1.3f_y$	f_y

Where:

f'_c = the specified 28 days compressive strength of concrete

f_y = lower characteristic yield strength of longitudinal reinforcement or structural steel

$f_{sy.t}$ = lower characteristic yield strength of transverse reinforcement steel.

Notes:

- The values for f_{sy}° , $f_{sy.t}^{\circ}$ and f_y° do not include allowance for strain hardening of the steel.
- For flexural reinforcement the values for the probable (expected) yield strength, f_{sye} , and for the maximum feasible (upper bound) yield strength, f_{sy}° , have been determined from a review of 2012 Pacific Steel test results. Where reinforcement from other sources of supply is proposed to be used appropriate values for f_{sye} and f_{sy}° should be assessed from representative test data.

ii. At other locations

Elements in ductile and limited ductile structures, intended not to yield, shall be designed in accordance with 5.6.1 for the actions (moments and axial loads) acting on them when induced by the horizontal seismic response mobilising the overstrength capacity of the plastic hinges and combined with permanent load actions. The redistribution of permanent load moments due to the plastic hinging shall be taken into account.

The formation of unintended plastic hinges shall be avoided by capacity design in accordance with 5.6.1 unless the structure as a whole is otherwise designed to remain elastic up to the CALS.

5.6.2 continued

Structures responding elastically when subjected to the DCLS design earthquake event shall be provided with sufficient dependable strength (ie based on characteristic material strengths given in column (3) of table 5.7 with capacity reduction factors as specified in 5.6.1) to withstand the load combinations specified in 5.3.2.

(Refer to the *Displacement-based seismic design of structures*⁽⁶⁾ sections 3.7 and 4.6, for guidance on the effects of stiffness reduction in the ductile member, the redistribution of the permanent load moments, and equilibrium considerations.)

iii. Serviceability limit state requirements

Prior to an earthquake, during serviceability limit state earthquake response, and following an earthquake where the structure is expected to be repaired and returned to service, the design of the structure shall also satisfy serviceability limit state requirements.

The capacity provided at plastic hinge locations, determined based on characteristic material strengths with normal capacity reduction factors applied, shall also be sufficient to withstand the serviceability limit state seismic actions determined using a return period factor of $R_u/4$ combined with the actions due to permanent loads corresponding to load combination 3A given in table 3.1.

Redistribution of gravity load moments is not permitted at the serviceability limit state unless a detailed study is undertaken to ensure a stable shake down situation arises and the deformations associated with this state do not conflict with serviceability requirements.

iv. Maintenance of stability and avoidance of ratcheting

The stability of the structure must be maintained and ratcheting avoided during and after the earthquake. The stability of beams cantilevering off portal frames as the extension of beams that are plastic hinging must be maintained by their cantilever moment being entirely reacted by their supporting columns. In structures with unbalanced lateral strengths and /or eccentric gravity loading causing ratcheting, the requirements of NZS 1170.5(1) clause 4.5.3 shall be complied with.

5.6.3 Required shear capacity and joint detailing for seismic actions

At all locations, shear forces resulting from seismic response mobilising the overstrength capacity of plastically deforming elements, shall be combined with shear forces resulting from the dead load of the structure and other permanent actions.

The design of the elements listed below for shear capacity shall comply with cited references, using the material strengths given in column (3) of table 5.7 and the strength reduction factors specified in 5.6.1:

- reinforced concrete elements carrying compression (*Displacement-based seismic design of structures*⁽⁶⁾ section 4.7.3)
- footings and pile caps (*Seismic design and retrofit of bridges*⁽⁵⁾ section 5.6)
- beam-column and footing/pilecap-column joints (*Seismic design and retrofit of bridges*⁽⁵⁾ sections 5.4 & 5.6).

Alternatively, the design and detailing of beam-column and footing/pilecap-column joints shall comply with NZS 3101⁽²⁾ clause 10.4.6.5 and chapter 15. In adopting the approach of *Seismic design and retrofit of bridges*⁽⁵⁾, while that approach seeks to alleviate reinforcement congestion at joints, the requirements of NZS 3101⁽²⁾ clause 10.4.6.5 to terminate the main flexural reinforcement with 90° hooks with the horizontal leg of the bend directed towards the far face of the column should be complied with to the maximum extent practicable.

5.6.3 continued

In the design of plastic hinge regions for shear, allowance shall be made for the degradation of the concrete contribution to shear strength with increasing curvature ductility demand as the seismic response increases from the DCLS up to the CALS. Adequate total shear strength shall be provided to ensure collapse avoidance at the CALS.

(Refer to *Displacement-based seismic design of structures*⁽⁶⁾ section 4.7.3 for guidance on the degradation of the concrete contribution to shear strength with increasing curvature ductility demand.)

5.6.4 Ductile structures and structures of limited ductility

a. Classification of ductility level for the application of materials design standards

For the purpose of aspects of earthquake resistant design for which reference to the relevant materials design standard is required, the structure shall be classified into one of the ductility classes given in table 5.8 based on the displacement ductility factor adopted for design:

Table 5.8: Classification of ductility level for design

Adopted structural ductility factor for design for the DCLS	Materials standards Structure classification
$3.0 < \mu \leq 4.0$	Ductile structure
$1.0 < \mu \leq 3.0$	Structure of limited ductility
$\mu = 1.0$	Elastically responding or brittle structure

b. Characteristics of a ductile structure

Under DCLS horizontal loading, a plastic mechanism develops. After yield, increasing horizontal displacement is accompanied by approximately constant total resisting force. A ductile structure must be capable of sustaining the adopted design ductility factor through at least four cycles to maximum design displacement, with no more than 20% reduction in horizontal resistance. For the purpose of determining the design load for force-based design, the design ductility value is restricted to four or less, as specified in 5.5.2 and table 5.6.

A structure of limited ductility as illustrated in figure 5.3, may otherwise qualify as ductile or partially ductile, but its proportions or detailing mean that its ductility capacity at the DCLS is low.

c. General requirements

In a ductile structure, where the ductility is provided by plastic hinges, the hinge probable^{*} flexural strengths shall be at least equal to the moments from an analysis as described in 5.3, 5.4 and 5.5. Hinge shear strength and the design of members resisting the hinge moments shall be according to capacity design principles as set out in 5.6.1. The capacity design requirements of this manual shall take precedence over those of NZS 1170.5⁽¹⁾ and the materials design standards that may be referred to.

Capacity design requirements will be considered satisfied if the overstrength flexural capacity of a hinge is matched by at least its own dependable[†] shear strength and the dependable shear and moment strength of resisting members forming the balance of the structure.

^{*} Probable strength: The theoretical strength of a member section calculated using the expected mean material strengths as defined in 5.6.2.

[†] Dependable strength: The theoretical strength of a member section, calculated using section dimensions as detailed and the lower 5 percentile characteristic material strengths, (ie the nominal strength) multiplied by the strength reduction factor specified by the relevant materials code.

5.6.4 continued

Pile analysis shall also consider the flexural and axial load consequences of seismic ground distortions such as lateral spread and settlement resulting from liquefaction. Pile caps and other members shall be designed to resist the vertical shear and other actions resulting from plastic hinging at pile tops, where this is considered likely.

In particular, plastic hinging in piles is to be avoided if practicable and within reasonable cost.

Where seismic design is based on ductile response and it is possible through appropriate design to ensure that plastic hinging will only occur in locations readily accessible for inspection and repair, ie above water level or less than 2m below the ground surface, capacity design as outlined in 5.6.1 shall be applied to ensure this.

d. Column detailing

Special consideration shall be given to the detailing of concrete compression members, bearing in mind the manner in which earthquake-induced energy will be dissipated and the desirability of avoiding brittle failures, especially in shear. In particular, the ultimate shear capacity shall be assessed and additional capacity provided, where necessary, to ensure that premature failure does not occur.

Where specific detailing requirements such as reinforcement anchorage or hook details are not covered in this section, compliance with the appropriate requirements of NZS 3101⁽²⁾ is required.

e. Potential plastic hinge zones

At potential plastic hinge locations, the zone of the plastic hinge, for the purpose of detailing the confining reinforcement, shall be taken to be the ductile detailing length as defined by NZS 3101⁽²⁾ clause 10.4.5. (The ductile detailing length should not be confused with the plastic hinge length to be applied to the calculation of plastic hinge curvatures and displacements, which is specified in 5.4.5.)

f. Longitudinal reinforcement

In reinforced and prestressed concrete compression members the cross-sectional area of the longitudinal reinforcement shall be not less than $4 \frac{A_g}{f_{yl}}$ and not be greater than $18 \frac{A_g}{f_{yl}}$, except that in the region of lap splices the total area shall not exceed $24 \frac{A_g}{f_{yl}}$, where A_g is area of the gross cross-section of the member and f_{yl} is the lower characteristic yield stress of longitudinal reinforcement.

Circular columns shall be provided with a minimum of 8 vertical bars for column diameters larger than 500mm, and a minimum of 6 vertical bars for smaller diameters.

Rectangular columns, shall be provided with a minimum of 8 vertical bars.

Groups of parallel longitudinal bars bundled to act as a unit shall have not more than 3 bars in any one bundle and shall be tied together in contact. This limitation also applies where bars are lapped.

g. Splicing and anchorage of longitudinal reinforcement

The splicing of longitudinal reinforcement shall conform with the requirements of NZS 3101⁽²⁾ clauses 8.9.1.1 and 8.9.1.2. Welded splices shall comply with NZS 3101⁽²⁾ clause 8.7.4. Mechanical coupling of reinforcement shall comply with clause 4.2.1(f) of this *Bridge manual*.

The anchorage of longitudinal reinforcement shall conform with the requirements of NZS 3101⁽²⁾ clause 10.4.6.5.

5.6.4 continued

h. Lateral reinforcement

The lateral (confinement) reinforcement in potential plastic hinge zones shall restrain the longitudinal reinforcement against buckling, confine the core concrete in the event that cover spalling occurs, and ensure that shear (brittle) failure will not occur during the design seismic event.

- i. Where spirals or circular hoops are used for the transverse reinforcement of plastic hinge zones, the volumetric ratio of the transverse reinforcement per unit length of member (ρ_s) shall provide adequate displacement capacity in accordance with 5.3.5, but shall not be less than $\rho_s=0.005$.

The pitch of spirals or circular hoops within potential plastic hinge zones shall be not greater than the smaller of:

$$0.15D_c \quad \text{and} \quad (5-47)$$

$$0.7 \left(3 + 6 \left(\frac{f_u}{f_y} - 1 \right) \right) d_{bl} \quad (5-48)$$

Where:

D_c = diameter of column

f_u = ultimate stress of the longitudinal reinforcement

f_y = yield stress of the longitudinal reinforcement

d_{bl} = diameter of longitudinal reinforcement.

Values for the ratio f_u/f_y shall be determined as specified in 5.4.5.

Where analysis indicates that the column will remain elastic under the DCLS design earthquake, the above limits may be relaxed to $0.25D_c$ and $8d_{bl}$.

- ii. Where closed rectangular ties are used for the transverse reinforcement of plastic hinge zones (see figure 5.5), the reinforcement shall provide adequate displacement capacity in accordance with 5.3.5, but shall not be less than $\rho_s=0.006$.

In addition to satisfying NZS 3101⁽²⁾ clause 10.4.7.6, the centre to centre distance of any unrestrained bar to a laterally restrained bar shall not exceed 150mm.

The spacing of the lateral confinement reinforcement shall not exceed the limits given in (i) above, where D_c in this case is the depth of the rectangular column in the direction considered.

Figure 5.5: Rectangular column tie spacings

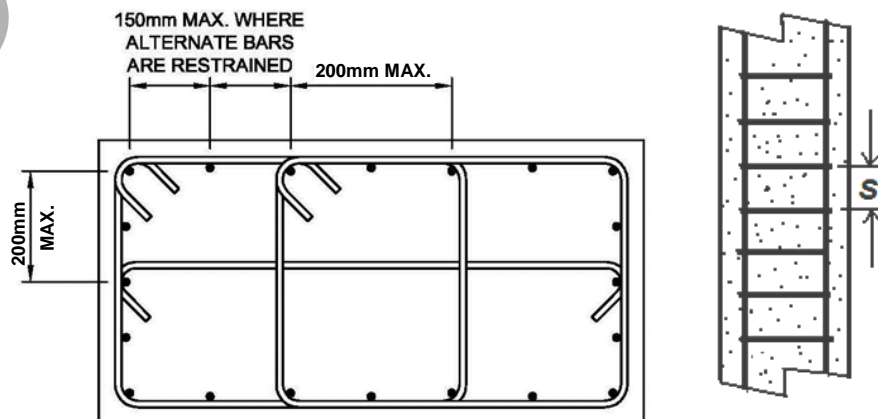

5.6.4 continued

- iii. Outside of potential plastic hinge zones, and for columns expected to remain elastic under the design earthquake, the spacing(s) of the lateral reinforcement shall not exceed the requirements of the relevant NZS 3101⁽²⁾ clauses: 10.3.10.4.3, 10.3.10.5.2, 10.3.10.6.2, 10.4.7.4.5, 10.4.7.5.5.

- i. Splicing and anchoring of lateral reinforcement

Splicing and anchorage of lateral reinforcement in plastic hinge zones shall comply with NZS 3101⁽²⁾ section 8.7 for the splicing of lateral reinforcement, NZS 3101⁽²⁾ clause 7.5.7.1 and 7.6.3.6 for the anchorage of stirrups and ties and with the following:

- i. Splicing of helices in potential plastic hinge zones shall be avoided. Where helices need to be spliced, splice the helices by lapping the helices one turn and then anchoring each end of the helix bars with a 135° hook, engaging a longitudinal bar. Alternatively, splice each helix bar to the other with a single sided lap weld complying with AS/NZS 1554.3 *Structural steel welding part 3 Welding of reinforcing steel*⁽²³⁾.

Spiral or circular hoop reinforcement shall be anchored using 135° hooks or by welding to itself. (Refer to Practice Advisory 8: *Don't be undone – anchor your spiral*⁽²⁴⁾.)

Quenched and tempered grade 500E reinforcement shall not be used where spirals and hoop reinforcement is to be anchored or spliced by welding.

Transverse reinforcement including stirrups, ties, spirals and hoops shall not be anchored by welding to longitudinal reinforcement.

- ii. Closed rectangular ties in accordance with 5.6.4(h)(ii) shall be used singly or in sets spaced vertically at not more than the value given by equation (5-48) or one-quarter of the minimum cross-section dimension, whichever is smaller.

Supplementary ties, of the same diameter as the closed ties, consisting of a straight bar with a 135° minimum hook at each end, may be considered as part of a closed tie if they are spaced horizontally at not more than 350mm centres and secured with hooks on the closed tie to the longitudinal bars.

- j. Additional provisions for rectangular / elliptical shaped piers

Where interlocking spirals are used, the overlap of the spirals should be at least 40% of the column diameter, as shown in figure 5.6.

Figure 5.6: Overlapping spiral reinforcement

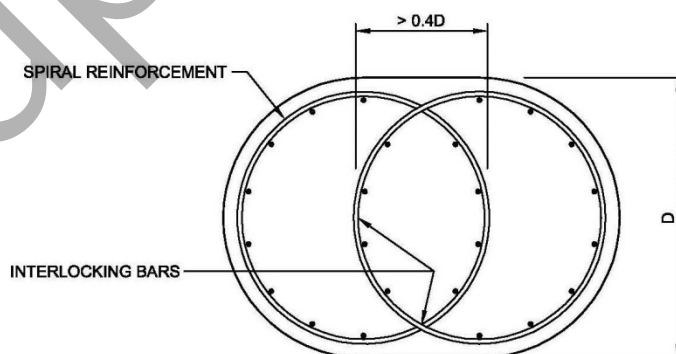

- k. Blade and wall type piers

Blade and wall type piers have a width to thickness ratio of 4 or greater.

The requirements of this sub-clause (k) apply to the design of blade and wall type piers for the strong direction.

The weak direction may be designed as a column in accordance with this sub-clause.

5.6.4 continued

Except in the end region (ie outer edges) of wall type piers the reinforcement ratios ρ_l longitudinally and ρ_s laterally shall not be less than 0.003 and ρ_l must not be less than ρ_s . In the end region, extending for twice the wall thickness from each end, but not less than 1.0m, the longitudinal reinforcement ratio shall be not less than 0.005.

Cross-ties shall be provided in wall type piers. In the end regions, defined above, cross ties shall comply with 5.6.4(h). Between end regions cross-ties shall be provided at spacing not exceeding twice the wall thickness both horizontally and vertically.

For blade or wall type columns, the centre-to-centre spacing between vertical bars shall not be greater than 450mm or 1.5 times the wall thickness, whichever is the lesser.

Outside of potential plastic hinge zones, and for columns expected to remain elastic under the design earthquake, the spacing(s) of the lateral reinforcement shall not exceed the requirements of the relevant NZS 3101⁽²⁾ clauses: 10.3.10.4.3, 10.3.10.5.2, 10.3.10.6.2, 10.4.7.4.5 and 10.4.7.5.5.

A layer of effectively orthogonal reinforcement shall be provided on each face of the pier.

Lateral reinforcement shall be continuous and uniformly distributed.

Splices for the vertical and lateral reinforcement shall be staggered.

i. Hollow columns

The longitudinal reinforcement for hollow columns shall be not less than $0.01A_g$ and not be greater than $0.06A_g$, where A_g is area of the concrete in the cross-section of the column.

For hollow rectangular columns provide a layer of effectively orthogonal reinforcement on each internal and external face, with detailing in accordance with this clause.

For hollow circular columns, a single layer only of effectively orthogonal reinforcement is permitted.

5.6.5 Partially ductile structure

In a partially ductile structure under DCLS horizontal loading, a plastic mechanism forms in only part of the structure, so that after yield there is a significant upward slope in the force/displacement relationship. As illustrated in figure 5.3 there are two types of partially ductile structure:

- In a type I structure, this continues up to design displacement.
- In a type II structure, a complete mechanism will form after further displacement but the load at which this happens may not be predictable if it is due to hinging in piles.

Potential plastic hinges that form in piers at close to the DCLS design loading, and their resisting members, shall be designed as in 5.6.4. Members that resist forces from plastic hinges that form at greater than design loading shall be designed on the same basis.

The dependable shear strength of piles shall exceed the shear developed by a possible mechanism at overstrength. Sections at potential plastic hinges at depth down the pile shall be detailed to ensure that they can sustain the expected plastic rotations without significant damage.

5.6.6 Structure remaining elastic at design earthquake loading

An elastic structure remains elastic up to or above the DCLS design load based on the elastic spectrum (unreduced by ductility but reduced for damping greater than 5% due to foundation damping). Elastic structures may have little or no reserve ductility after reaching their load capacity, which, while undesirable, may be unavoidable.

5.6.6 continued

The pier and foundation member design forces shall be determined on the basis of an analysis as described in 5.3 and 5.4 or 5.5. If practicable or economically justifiable, damage during seismic overload should occur in accessible locations. The design strengths* of members below ground shall at least match the nominal flexural strengths† of members above ground.

All elastic structures shall be provided with either or both sufficient strength and sufficient ductility to be able to withstand a CALS earthquake event (ie an event corresponding to return period factor of $1.5R_u$) without collapse. For elements not designed on the basis of capacity design for the actions induced by yielding members mobilising their overstrength capacity, design shall be based on characteristic material strengths with capacity reduction factors applied. The flexural members of the substructure shall be detailed for ductility as required for a structure of limited ductility unless it can be demonstrated that plastic hinging is very unlikely. Columns and piles shall be provided with minimum confinement steel ratios (ρ_s) of not less than 0.005 and 0.006 for circular and rectangular sections respectively.

In the design of an elastically responding structure, no moment redistribution shall be applied other than that permitted by NZS 3101⁽²⁾ section 6.3.7 to non-seismic loads.

5.6.7 Structure anchored by a friction slab, deadman anchors, soil reinforcement, abutment piles or base friction

- a. Friction slabs, deadman anchors or soil reinforcement, piles (if provided) and friction on the base of abutments (provided they are not piled) may be assumed to provide seismic anchorage to a bridge abutment to resist both inertia loads from the abutment and superstructure only if the integrity of the embankment within which they are located can be relied upon under earthquake conditions (see 5.1.3 and 5.6.13(a)). The effect of seismic load transmitted by the friction slab, deadman anchors or soil reinforcement, piles, or friction on the base of an abutment to the embankment shall be taken into account in assessing the integrity of the embankment.
- b. The horizontal restraint provided by a friction slab, deadman anchors or soil reinforcement, piles acting alone or in combination, and abutment (if not piled) base friction shall at least match the design force on the abutment specified in figure 6.4(a).
- c. Allowance shall be made for seismic inertia forces arising from the weight of the friction slab and overlying soil, the weight of the deadman and passive soil wedge, or from the weight of the reinforced soil block, reducing the restraint provided to the structure.
- d. The design value of horizontal restraint provided by a friction slab shall be calculated as the lesser of the design value of friction between the slab and the underlying bedding, and the design value of friction between the bedding and the underlying natural ground or fill. A strength reduction factor of $\phi=0.8$ shall be applied in the determination of the design value of friction.
- e. The assessment of the restraint provided by a friction slab shall take into account the extent to which the friction slab maintains contact with the underlying ground or fill in the event of settlement occurring. In general, the friction slab should be detailed in a manner to ensure that it maintains contact with the underlying ground throughout most of its length. Typically, where the abutment is supported on piles, this is usually achieved by detailing the friction slab to hinge at the rear of the abutment sill beam and again at a short distance away from the rear of the abutment sill beam. Friction slabs detailed in such a way would not provide the benefits of a settlement slab.

* Nominal strength: defined as the theoretical strength of a member section, calculated using the section dimensions as detailed and the lower characteristic strengths of the reinforcement and concrete.

† Design strength: defined as the nominal strength multiplied by the appropriate strength reduction factor.

5.6.7 continued

- f. The design strength of the connection between the friction slab, deadman anchor or soil reinforcement and the abutment shall be at least 1.3 times the nominal sliding resistance of the friction slab, deadman anchor or soil reinforcement.
- g. For multi-span bridges, abutment restraint by friction slabs and other forms of soil anchorage shall be assumed to provide no more than 30% of the total longitudinal and transverse lateral load resistance required. Piles at the abutments and the flexural strength of the piers shall be designed to carry the remaining part of the lateral load.

5.6.8 Structure 'locked in' to the ground longitudinally

Only single span structures, or multi-span structures up to 35m in length, with integral or semi-integral abutments, as described in 4.8, may be treated as structures 'locked-in' to the ground longitudinally. These structures rely on the integrity of the abutment approach material for seismic resistance. Refer to 5.6.13 for the specification of constraints to the restraint that can be assumed to be provided by abutments.

These structures are assumed to move with the ground displacement and for design purposes are assumed to be subjected to ground acceleration without amplification. Longitudinally there are two common cases as outlined in (a) and (b) below.

The forces acting on the locked-in structure, that are to be designed for, are illustrated in figure 5.7. The peak horizontal ground acceleration coefficient (C_o) to be used in computing the seismic inertia force shall be not less than as follows:

$$C_o = C_h(T_0)ZR_u \quad (5-49)$$

Where:

$C_h(T_0)$ = spectral shape factor at $T=0$ applicable to modal response spectrum and numerical integration time history analysis from NZS 1170.5⁽¹⁾ clause 3.1.2

Z = hazard factor from 5.2.2(a) and NZS 1170.5⁽¹⁾ clause 3.1.4

R_u = DCLS return period factor from 5.2.2(b).

Resistance to longitudinal seismic loads shall be provided by pressure of soil against each abutment alternately. Earth pressure shall be determined as in 6.2.4, but to allow for possible seismic overload, greater pressure shall be allowed for, up to a maximum equivalent to passive pressure based on upper bound soil strength estimates without the application of reduction factors in the design of structural elements such as abutment backwalls. Conservative values of soil strength parameters shall be adopted in assessing the soil passive resistance and the frictional resistance to the structure sliding, and a strength reduction of $\phi=0.8$ shall be applied to both forms of resistance.

Forces in the foundations due to consequent soil deformation shall be determined by an appropriate analysis, including the effects of soil stiffness. Such a structure shall not be assumed to be locked-in for transverse earthquake, unless a specific resisting system is designed.

- a. Single span with conventional integral or semi-integral abutments on either piles or spread footings

For this case the resistance shall be provided by piles, passive resistance, or friction from friction slabs (and footings if not piled), or a combination of these resisting components. The passive resistance shall be reduced by the 0.7 PGA acting on the passive wedge. The active earthquake pressure component shall be assumed to act on the abutment moving away from the soil embankment. Where the abutments are not supported on piles and sliding displacements of up to 50mm are considered acceptable the response acceleration assumed to act on the superstructure and abutment structure in either the longitudinal or transverse direction may be taken as $0.7 \times \text{PGA}$.

Figure 5.7: Seismic force combinations acting on a locked-in structure

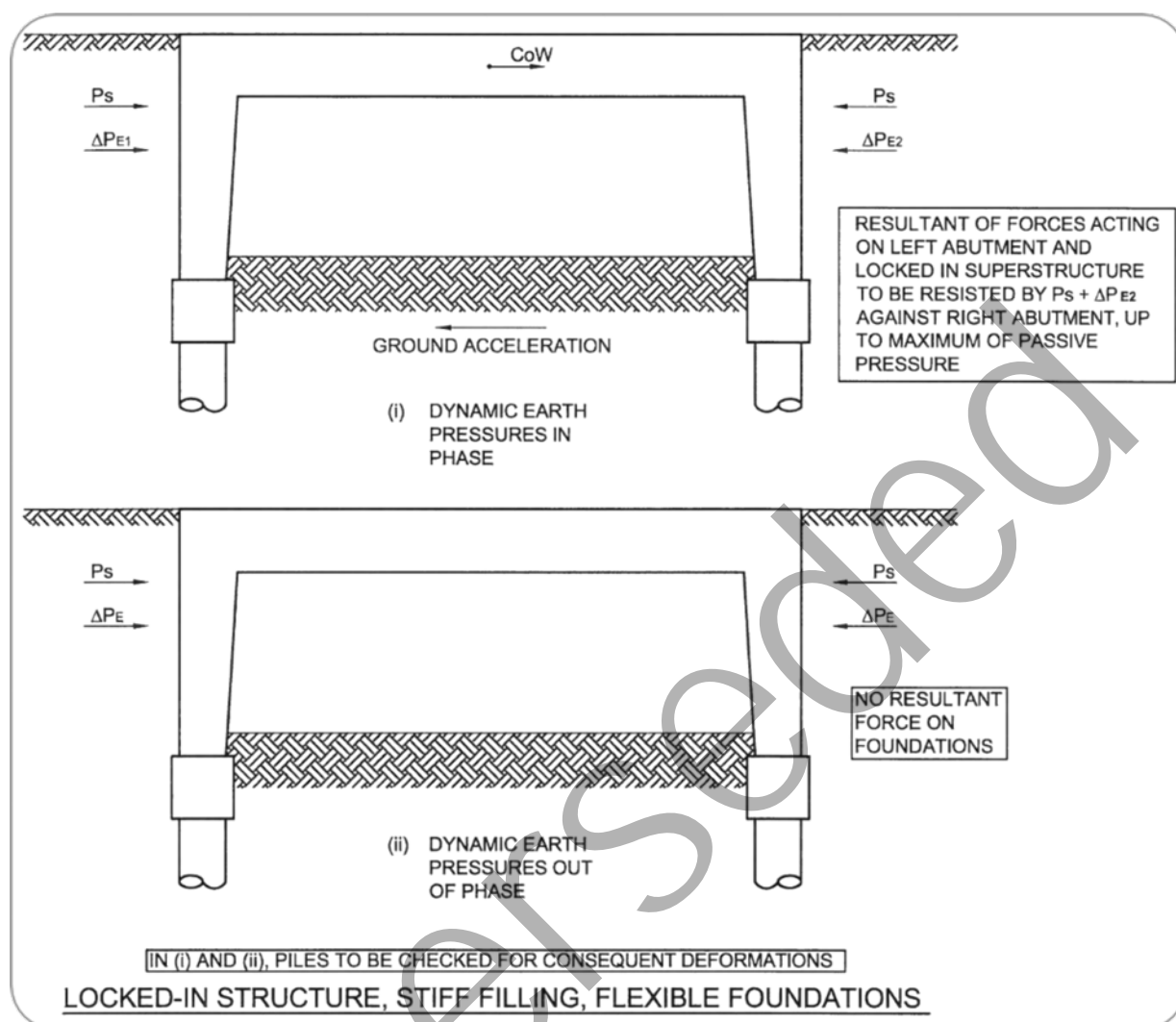

5.6.8 continued

b. Portal frame structure with abutment walls higher than 3.0m

For this case the resistance shall be provided by passive resistance or piles or a combination of both. Potential plastic hinge areas in the walls and piles shall be detailed to meet the requirements for a structure of limited ductility (as defined in 5.6.4(a)).

The earthquake component of soil pressure acting on the walls shall be assumed to be in-phase increasing the static at-rest pressure on one wall and reducing the static at-rest pressure on the other wall. In lieu of more detailed analysis, the earthquake pressure component coefficient may be taken as $0.5 \times \text{PGA}$ with the pressure assumed to be uniform over the height of the wall (stiff wall assumed coefficient of 0.75 reduced by a factor of 0.7 to allowing for damping and wave scattering). The response acceleration acting on the structure (walls and superstructure) shall be taken as the PGA.

As an alternative to the above analysis procedure the structure may be assumed to be subjected to soil shear-strain racking where the shear strain is computed from the free-field shear strain over the height of the structure under the DCLS event and the relative shear stiffness between the soil and structure. The response acceleration on the structure shall be taken as the PGA. Details of this method are described in *Earthquake design of rectangular underground structures*⁽²⁵⁾.

5.6.9 Multiple span bridges restrained longitudinally by ground passive resistance

This is a structure with integral or semi-integral abutments and without movement joints in the superstructure which relies substantially on the integrity of the abutment approach material for longitudinal seismic resistance although the piers may provide a proportion of the longitudinal restraint. Effectively, due to the spring stiffness of the restraining ground behind the abutments, this structure will exhibit response to an amplified acceleration, greater than the peak ground acceleration, at a period greater than $T=0$. But also due to the soil-structure interaction, increased damping of the response may arise.

For multi-span bridges the period of vibration shall be assessed as the basis for deriving the design seismic response spectrum. Increased damping may be taken into account to reduce the design elastic response spectrum. Passive and sliding resistance developed at abutment walls and footings may be considered to provide up to 30% of the total longitudinal and transverse resistance provided the stability of the abutment embankments and backfills is assessed and found to be satisfactory at the DCLS. A strength reduction factor of $\phi=0.8$ shall be applied to the estimated soil passive and sliding resistance and the remaining resistance shall be provided by the piers and abutment piles (if any).

5.6.10 Structure on pile/cylinder foundations

- a. When estimating foundation stiffness to determine the natural period(s) of vibration of the structure and the curvature ductility demand on plastic hinges, a range of soil stiffness parameters typical for the site shall be considered. Allowance shall be made for:
 - residual scour, which shall be taken to comprise thalweg plus general scour under mean daily flow conditions. Allowance shall also be made for any long term degradation that is occurring of the river
 - pile/soil separation in cohesive soils to a depth of two times pile diameter
 - liquefaction of soil layers and the potential for soil stiffness and strength degradation under repeated cyclic loading associated with earthquakes
 - the non-linear stress-strain properties of the resisting ground
 - the contribution of permanent steel casing to the stiffness of the pile, taking into account the extent of bond development between the casing and the concrete core, and section loss due to corrosion.
- b. The design of pile foundations shall take account of:
 - pile group action
 - strength of the foundation as governed by the strength of the soil in which the piles are embedded
 - the effect of liquefaction-induced lateral spreading of the ground
 - additional loads on piles such as negative skin friction (down-drag) due to subsidence induced by liquefaction or settlement of the ground under adjacent loads (such as the approach embankment).

The horizontal support provided to piles by liquefied soil layers and overlying non-liquefied layers shall be assessed using appropriate current methods for determining liquefied or post-liquefied soil strength and stiffness. Alternatively, for liquefied soil layers their horizontal support to piles may be conservatively ignored.

5.6.10 continued

Where permanent steel casing is to be used to contribute to the axial load and flexural strength of the pile or cylinder, allowance shall be made for the casing section loss due to corrosion, the casing thickness shall comply with NZS 3101⁽²⁾ clause 10.3.11.6.1, and the design for composite action shall comply with the requirements of AS/NZS 5100.6⁽²²⁾ sections 10.6 and 11.5 or BS EN 1994 *Eurocode 4 Design of composite steel and concrete structures*⁽²⁶⁾ section 6.7.

- c. The required strength of the piles, pile caps and the connection between these elements to resist the loads induced by seismic action shall be in accordance with the criteria above as appropriate. In addition:
- the design tensile strength of the connection between a pile and the pile cap shall not be less than 30% of the tensile strength of the pile based on probable material strengths. In determining the tensile strength of the pile the strength of the casing shall be excluded where it is not effectively anchored to the pile cap.
 - the region of reinforced concrete piles extending for the larger of the ductile detailing length defined by clause 10.4.5 of NZS 3101.1⁽²⁾, twice the pile dimension, or 500mm from the underside of the pile cap shall be reinforced for confinement as a plastic hinge. (The pile dimension shall be taken as the diameter of a circle of area equivalent to the pile cross-sectional area.)
- d. In the region of a steel shell pile immediately below the pile cap, the contribution of the shell (after deducting corrosion losses) may be included with respect to shear and confinement but shall be neglected in determining moment strength unless adequate anchorage of the shell into the pile cap is provided.

Where plastic hinging may occur in piles at the soffit of the pile cap the casing shall be terminated at least 50mm but not greater than 100mm below the pile cap soffit and any associated blinding concrete. This is to prevent the casing acting as compression reinforcement, which can cause buckling of the casing and enhancement of the pile strength by an indeterminate amount affecting the capacity design of the structure. The plastic hinge length in this situation, arising from strain penetration both up into the pile cap and down into the pile, shall be taken to be:

$$L_p = g + 0.044f_y d_b \quad (5-50)$$

Where:

- L_p = plastic hinge length
- g = the gap between the pile cap soffit and the top of the casing (mm)
- f_y = yield strength of the pile flexural reinforcement (MPa)
- d_b = diameter of the pile flexural reinforcement bars (mm).

The reduction in curvature ductility and displacement capability resulting from this limited plastic hinge length shall be taken into account in design.

- e. Piles may develop unintended potential plastic hinge positions at the top of the piles and at locations down the pile where there is an abrupt change in soil stiffness. Where plastic hinging may occur at depth in the ground, adequate confinement of the plastic hinge zone shall be provided for a distance of at least three times the pile diameter either side of the level of maximum moment, taking into account the possible variability of this level due to such factors as the variability in the soil stiffness, variability in the depth of scour, and liquefaction of soil layers. Allow also for migration of the location of maximum moment upwards towards the ground surface as plasticity in the pile develops with the final depth being approximately 70% of that predicted by elastic analysis. (Refer *Seismic design and retrofit of bridges*⁽⁵⁾ section 5.3.2(b).)

5.6.10 continued

- f. When a permanent steel pile casing is used, even if it is intended to be non-structural, the effect of it acting compositely shall be considered and the steel shall meet the material requirements of AS/NZS 5100.6⁽²²⁾ section 2 or appendix H, or the withdrawn NZS 3404.1:2009 *Steel structures standard*⁽²⁷⁾ section 2 and all welds shall be full strength butt welds.
- g. Analyses of the effect of seismic loading on groups of raked piles shall take account of the simultaneously induced axial forces and flexure in the piles and rotation of the pile cap due to lateral displacements.

5.6.11 Structure on spread footing foundations

The soil stress induced by load combination 3A shall not exceed the product of the nominal bearing capacity of the soil and the appropriate strength reduction factor derived in accordance with 6.5.3. The foundations shall be considered under the combined static and earthquake loads.

5.6.12 Structure with rocking piers or on rocking foundations

Structures incorporating rocking of substructure elements include the following:

- structures in which spread footings rock on the supporting soils or rock
- structures in which the supporting columns rock on their structural foundations (spread footing or tops of foundation cylinders)
- structures in which the supporting columns rock on their structural foundations (spread footing or tops of foundation cylinders) and which incorporate mechanical energy dissipation devices to dampen seismic response.

Structures in which spread footings rock on the supporting soil or rock, and structures in which supporting columns rock on their structural foundations and without the incorporation of mechanical energy dissipating devices, are special cases of a ductile structure that remains elastic, in which spread footing foundation or column rocking is associated with rotation about one edge of the foundation or column base transferring to rotation about the other edge in a clear stepping action and the deformation of the soil and impact effects provide energy dissipation and increased damping. In using force-based design, for this structural system a value of $\mu=1.0$ shall be adopted and the increased damping may be taken into account.

Where mechanical energy dissipation devices are incorporated the structure will respond inelastically. The mechanical energy dissipation devices are usually positioned distributed around the base of the supporting columns that rock on their structural foundations and are activated by the rocking motion of the columns. A restoring force to promote the column to return to its initial vertical position may also be provided by an unbonded prestressed cable positioned down through the centre of the column and anchored into the structural foundation.

- a. Piers founded on spread footings may be expected to rock when the proportions of the spread footings are insufficient to withstand the overstrength moment capacity of a plastic hinge forming in the pier. If pier spread footings are expected to rock under design DCLS earthquake conditions to the extent that complete decompression of the bearing pressure and loss of ground contact beneath an edge of the spread footing occurs, the structure's behaviour shall be studied, preferably by performing a time history dynamic analysis in accordance with 5.3.11(d). The stiffness properties of the soil or rock shall be considered in the analysis.

5.6.12 continued

As an alternative to the dynamic analysis, a simplified analysis based on equilibrium consideration, as described in appendix A of the *AASHTO Guide specifications for LRFD seismic bridge design*⁽²⁰⁾, may be carried out. Where this simplified method is adopted for design, geotechnical capacities of the foundations, including assessment of potential settlement, shall be assessed to ensure that undesirable systems do not jeopardize the resistance or stability of the bridge system. Overturning shall be prevented under a CALS event. (The simplified method is also outlined in *Seismic design and retrofit of bridges*⁽⁵⁾ section 6.4.2.)

- b. For piers founded on rocking spread footings, the footing and pier stem shall be designed based on capacity design principles, to ensure that any yielding occurs in the pier stem. Capacity design requirements will be satisfied if the overstrength flexural capacity of the pier hinge is matched by at least its own nominal shear strength, the design moment and shear capacity of the footing and the bearing capacity of the foundation.

The potential plastic hinge region at the base of the pier stem shall be detailed to ensure that it can sustain the possible limited rotation.

- c. The interaction of the structure and foundation during rocking shall be carefully considered in the assessment of a rocking foundation, and the potential for foundation strength and stiffness degradation shall be taken into account.
- d. Structures supported on columns that rock on their structural foundations, whether or not they incorporate mechanical energy dissipation, shall have the structure's behaviour studied as specified in (a). Structures incorporating mechanical energy dissipation shall also satisfy the requirements of 5.6.14. Whether or not mechanical energy dissipation devices are incorporated, consideration should also be given to the need or desirability of providing a restoring force that will act to reduce displacement of the structure and promote the displaced column to return to its original vertical position.
- e. For all types of structure incorporating the rocking of substructure elements, an assessment shall be made of the performance of both the structural and non-structural components of the bridge as a consequence of the vertical and horizontal movements associated with the rocking motion of the piers, to ensure that structural integrity will be maintained under both DCLS design, and more extreme CALS earthquake conditions. The structure should be proportioned to ensure that displacements under CALS conditions are not sufficient to precipitate instability.
- f. Structures founded on piles shall have their foundations proportioned such that rocking through the capacity of piles in tension being exceeded does not occur under the design DCLS intensity of earthquake shaking.

5.6.13 Constraints on the restraint assumed to be provided by abutments

In the assessment of restraint provided by abutments to a bridge, the following constraints shall apply:

- a. The embankments may only be relied on to provide restraint provided they will maintain their stability and capability to provide restraint at the DCLS event and that avoidance of collapse of the structure in a CALS event is assured (see 5.1.3).
- b. For abutments supported on piles, frictional restraint from the soffit of the abutment bearing against the underlying soil shall not be assumed due to the likelihood of embankment settlement occurring during a major seismic event.

5.6.13 continued

- c. Under transverse response, frictional restraint from the embankment backfill acting against the rear face of the abutment or a vertical plane at the rear edge of the settlement slab shall not be assumed due to the likelihood of this restraint being diminished by possible gapping caused by the longitudinal response.
- d. Under transverse response, abutment wingwalls bearing against backfill overlying a settlement slab do not mobilise restraint from this backfill as it responds with the abutment.

5.6.14 Structure with energy dissipating devices

A structure incorporating energy dissipating devices shall be designed in a similar manner to a ductile structure, as in 5.6.4. The energy dissipating devices shall be treated similarly to plastic hinges, and members resisting the forces induced in them designed using capacity design principles.

Energy dissipating devices shall have had their performance substantiated by tests. Their long-term functioning shall be assured by protection from corrosion and from water or debris build-up. The devices shall be accessible for regular inspection and maintenance, and to enable them to be removed and replaced if necessary.

Design guidance is contained in Road Research Unit bulletin 84, volume 3 *Seismic design of base isolated bridges incorporating mechanical energy dissipators*⁽²⁸⁾ and is also provided by the AASHTO *Guide specifications for seismic isolation design*⁽²⁹⁾.

Base isolation and energy dissipation devices shall maintain their integrity and functionality under earthquake events up to the magnitude of the CALS event.

5.6.15 Provision for foundation settlements

Where foundation settlements due to DCLS earthquake response and any associated liquefaction and/or ground movement of greater than 25mm are predicted, provision shall be made in the bridge detailing for jacking and re-levelling of the bridge superstructure to achieve the original design levels. Major reconstruction of primary substructure elements shall not be required. After reinstatement, the design level actions to be catered for shall include the effects of any permanent seismic settlement of the foundations and any additional actions arising from the re-levelling.

5.7 Provision for relative displacements

5.7.1 Clearances

a. Structural clearances

At locations where relative movement between structural elements is designed to occur, sufficient clearance shall be provided between those elements and around such items as holding down bolts, to permit 2.0 times the calculated relative movement under design DCLS earthquake conditions to occur freely without inducing damage. Similarly, bearings shall be designed to accommodate this range of movement without spans unseating.

Where two components of earthquake movement may be out of phase, the earthquake component of the clearance provided may be based on the square root of the sum of the squares approach. Long-term shortening effects and one third of the temperature induced movement from the median temperature position shall be taken into account as implied by the load combinations in table 3.2.

On short skew bridges, consideration shall be given to increasing the clearance between spans and abutments by up to 25% to counter possible torsional movement of the span with respect to the substructure.

b. Deck joints

At temperature movement deck joints, clearances may be less than specified in (a), provided damage to structural elements due to the design DCLS earthquake is limited to sacrificial devices (knock-up or knock-off devices), which have intentional weakness that permits localised damage to occur in a predetermined manner.

In such circumstances the range of movement to be accommodated by the joint shall not be less than the calculated relative movement under the serviceability limit state design earthquake conditions corresponding to a return period factor of $R_u/4$, plus long-term shortening effects where applicable, and one-third of the temperature induced movement from the median temperature position. Damage to deck joint seal elements due to the joint opening under this reduced earthquake movement is acceptable. Mechanical damage, however, is to be avoided under the joint both opening and closing under the DCLS movements (ie damage to the jaws retaining the seals, joint fixings or primary joint elements other than flexible glands).

c. Provision for extreme seismic movements

Where movements outside the range of conventional bearings or clearance provisions are expected, additional devices may be used to limit movements under earthquake loading only. These special devices, such as buffer bearings, shall be designed to be activated only by large displacements, or by high relative velocities. The influence of such devices on the distribution and magnitude of earthquake force in the bridge shall be fully evaluated and considered in the design of all structural elements.

d. Clearance between adjacent structures

The clearance between adjacent structures to be provided shall exceed the desired minimum clearance of the sum of 2.0 times the displacement under the DCLS event of each structure. Additional compensatory clearance shall be provided where there is the possibility of components of displacement arising due to soil lateral spreading, soil cyclic softening or other non-seismic loadings or effects that may reduce the clearance provided.

5.7.1 continued

Where agreed by the road controlling authority, the separation between the adjacent bridges may be reduced, but to not less than an absolute minimum separation of the square root of the sum of the squares of the DCLS deflection of each bridge. Justification for this reduction shall be presented in the structure design statement.

Where less than the desired minimum clearance is provided, measures shall be taken to prevent injury to persons on or below the bridge, caused by falling debris (eg barriers or downstands to barriers). In addition, elements providing restraint to the superstructures of the bridges (eg shear keys) shall be designed to withstand any increased forces they may sustain due to pounding between the structures.

5.7.2 Horizontal linkage systems

a. General

The security of all spans against loss of support during seismic movement shall be ensured. Outlined below, situations are described where a positive horizontal linkage system shall be provided, and other situations are described where, as an alternative to the provision of a linkage system, specific provision for large relative displacements may be provided.

Linkage may be either tight or loose as described in (b) and (c), according to whether relative longitudinal movement is intended.

Requirements for provision of linkage are as follows:

- Longitudinal linkage is required between all simply supported span ends and their piers, and between the two parts of the superstructure at a hinge in the longitudinal beam system. This requirement shall also apply to abutments supported on walls or MSE fills, or with batter slopes in front of them steeper than 1.5 horizontal: 1.0 vertical. Longitudinal linkage is not required at a spill-through abutment with batter slopes flatter than or equal to 1.5 horizontal : 1.0 vertical, provided that the overlap requirements of 5.7.2(d) are complied with.
- Longitudinal linkage is not required at a pier, for a superstructure with full moment continuity, provided the displacement of the reaction point would not cause local member distress.
- Transverse linkage is not required for any type of superstructure, other than multi-beam superstructures with the beams each supported on individual columns, provided that the transverse strength and stability of the span is sufficient to support an outer beam or truss if it should be displaced off the pier or abutment.
- In the case of multi-beam superstructures with the beams each supported on individual columns, transverse linkages shall be provided between the tops of the columns and the superstructure to prevent excessive relative transverse displacement between the columns and the superstructure and the overlap requirements of table 5.9 shall be satisfied.

Linkage elements shall be ductile, in order to ensure integrity under excessive relative movement. Acceptable means of linkage are linkage bars. Requirements for ductile linkage bars are given in appendix C. Elements anchoring linkage bars shall be capacity designed to withstand elastically the forces imposed on them by seismic response loading the linkage bars to their overstrength capacity.

Ductile shear keys (eg concrete infilled steel tubes) are also acceptable provided that they are designed to withstand elastically the force induced in them by plastic hinges or mechanical energy dissipating devices developing their overstrength capacity under seismic response. Bearings, other than fixed pot bearings designed on a capacity design basis, are not an acceptable means of linkage.

5.7.2 continued

Due to the nature of earthquake loads, horizontal restraints shall not rely on any component of friction, unless the surface across which frictional restraint is to be transferred is designed and constructed as a shear-friction concrete construction joint between different stages of construction with reinforcement crossing the interface. Otherwise, for assessment of the structure under any load combination which includes earthquake effects, the friction coefficient between any material types to be used when determining horizontal restraint shall be taken to be equal to zero. However, an upper-bound estimate of the coefficient of friction shall be assumed for determination of maximum feasible force transmitted by friction through material interfaces, when assessing demand on structural elements, such as piers, for capacity-demand conditions in accordance with 5.6.1.

b. Tight linkage

A tight linkage shall be used, where relative horizontal movement is not intended to occur under either service loads or seismic loading. In ductile structures and structures of limited ductility, the linkage system shall be designed to have a design strength not less than the force induced therein by capacity design actions arising under DCLS design seismic conditions. Nor shall the design strength be less than that prescribed below for loose linkage. The linkage system of structures responding elastically at the DCLS shall be provided with either or both sufficient strength and sufficient ductility to prevent span collapses in a CALS earthquake event. Where applicable, rubber pads shall be provided between the two elements of the bridge linked together in this fashion, to enable relative rotation to occur.

c. Loose linkage

At a position where relative horizontal movement between elements of the bridge is intended to occur under DCLS design earthquake conditions, the linkage shall be designed to be 'loose', ie sufficient clearance shall be provided in the system so that it does not operate until the relative design seismic displacement plus long term shortening plus one-third of the temperature induced movement from the median temperature position is exceeded. Loose linkage is intended to act as a second line of defence against span collapse in earthquakes more severe than the design event, up to the CALS event or in the event of pier top displacement resulting from excessive pier base rotation.

Toroidal rubber buffers as shown in appendix C shall be provided between the elements of the bridge which are loosely linked. The elements of loose linkage between a span and its support shall have a design strength not less than that required to resist a force equal to at least 0.4 times the dead load of the contributing length of superstructure. The contributing length of superstructure shall be not less than the total length of the spans being supported on the abutment or pier fitted with the linkage system.

d. Overlap requirements

Overlap dimensions are defined in figure 5.8. They apply in both longitudinal and transverse directions.

To minimise the risk of a span being displaced off either its bearings or the pier or abutment under earthquake conditions in excess of the design event, the bearing overlap at sliding or potentially sliding surfaces and the span/support overlap of not less than that given in table 5.9 and, at non-integral abutments, by equation (5-51), whichever is the greater, shall be provided.

5.7.2 continued

At non-integral bridge abutments at which linkages are not provided, bearing seats supporting expansion ends of the superstructure shall be designed to provide a minimum support overlap length, measured normal to the face of an abutment, of not less than that required by table 5.9 and also not less than L_{bs} , as expressed in equation (5-51).

$$L_{bs} = \Delta(3.0) + 0.0004L_d + 0.007h_d + 0.005W \geq 0.4m \quad (5-51)$$

Where:

$\Delta(3.0)$ = the displacement at a period of 3 seconds for the design seismicity (5.2.4(b))

L_d = length of the superstructure to the next expansion joint

h_d = average height of the columns or piers supporting the superstructure length L_d

W = width of the seating transverse to the bridge axis.

Figure 5.8: Overlap definition

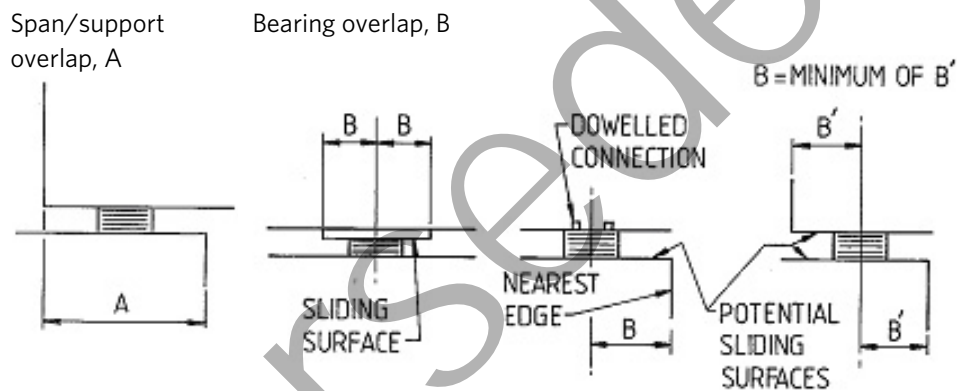

Table 5.9: Minimum overlap requirements

Linkage system	Span/Support overlap (A)	Bearing overlap (B)
No linkage system	$2.0E + 100\text{mm}$ (400mm minimum)	$1.25E$
Loose linkage system	$2.0E' + 100\text{mm}$ (300mm minimum)	$1.0E'$
Tight linkage system	200mm	-

Where:

E = relative movement between span and support, from median temperature position at construction time, under DCLS design earthquake conditions, EQ+SG+TP/3

E' = equivalent relative movement at which the loose linkage operates, ie $E' \geq E$.

EQ, SG and TP are displacements resulting from load conditions described in section 3 and combined as in table 3.2.

5.7.3 Holding down devices

See 2.1.7.

5.7.4 Effects of concurrent orthogonal movement

Provision shall be made for the effects on linkage and bearing assemblies of relative horizontal seismic movement between bridge elements occurring concurrently in the longitudinal and transverse directions.

5.8 Tsunami effects on coastal bridges

5.8.1 Introduction

The understanding of tsunami effects on coastal structures is in its infancy. The following outlines provisional requirements for the consideration of tsunami effects on coastal bridges and has been developed from research undertaken by the University of Auckland detailed in their reports *Outline for designing bridges that may be subjected to tsunami loads* stage 1 Literature review: New Zealand's exposure to tsunami hazard, bridge failure mechanisms and existing design guidelines⁽³⁰⁾ and stage 2 Draft requirements for the consideration of tsunami effects on bridges⁽³¹⁾.

This is a topic that is the focus of ongoing research effort and it is expected that these requirements will be modified as the state of knowledge develops.

5.8.2 Consideration of design for tsunami effects

The need for a structure to be designed for the effects of tsunami, and the required design performance level, shall be agreed on a case by case basis with the road controlling authority. The need for and performance level of the design shall be based on:

- an assessment of the capacity of the structure to withstand tsunami effects when there has been no specific design for tsunami. As a minimum requirement, bridges potentially affected by tsunamis shall be designed to ensure that the superstructure is connected to the substructure in a manner that the horizontal and vertical (uplift) capacity of the substructure can be fully developed to resist the tsunami load effects on the superstructure.
- consideration of the incremental cost to increase the capacity of the structure from including no specific design for tsunamis to designing for tsunamis of increasingly lesser annual probability of exceedance down to the annual probability of exceedance of the design earthquake event.
- recognition that the level of tsunami design principally affects the extent of post-tsunami bridge damage rather than road user safety. Road users will generally be adversely affected, regardless of bridge performance.

5.8.3 Design events

The annual probability of exceedance for the full design tsunami event shall correspond to that for damage control limit state earthquake actions given in table 2.1.

The maximum tsunami height at the coastline shall be determined from figures 5.9(a) to 5.9(f) as appropriate for the design annual probability of exceedance. For each colour band, the maximum tsunami height represented by the colour band shall be adopted (eg for the yellow band, an 8m high tsunami height shall be adopted). For zones colour coded black, a maximum tsunami height of 14m shall be assumed. The maximum tsunami height shall be assumed to be its height above mean sea level (ie its elevation). Future increases in mean sea level should be taken into account, as specified in 2.3.2(c).

(Note: These tsunami heights are relative to the sea level at the time of an event occurring, but for the purpose of this consideration these tsunami heights shall be treated as being relative to mean sea level, as an average event.)

5.8.4 Tsunami overland maximum run-up elevation

Coastal bridges will commonly be waterway crossings discharging at bays in the coastline which are likely to have a focusing effect on the impact of the tsunami against the coastline. Taking this effect into account, the maximum elevation above mean sea level that the tsunami shall be assumed to run up to overland and up waterways shall be taken to be twice the maximum tsunami height at the coastline.

* Figures 5.9(a), 5.9(c) and 5.9(e) have been reproduced from *Review of tsunami hazard in New Zealand (2013 update)*⁽³²⁾ with the permission of the Ministry of Civil Defence and Emergency Management and GNS Science.

5.8.4 continued All bridges sited on ground or in water with a surface elevation lower than this maximum run-up elevation shall be considered to be exposed to the effects of tsunamis. In determining the maximum run-up elevation, allowance shall be made for the effects of climate change.

5.8.5 Inland tsunami flow velocity Typically, tsunami waves break as they reach the coast and will run inland as a 'bore' (broken wave). The flow depth of this bore and its velocity will diminish as the elevation of the surface over which it is flowing increases and both will be zero at the maximum run-up elevation. The flow depth of the bore at the bridge location shall be assumed to be:

$$y_t = H_c \left(1 + \frac{x}{L}\right) - H_b \quad (5-52)$$

Where:

y_t = tsunami flow depth at the bridge; ie height of the tsunami surface above the pre-tsunami water level or above the ground surface if the stream bed at the bridge is dry (m)

H_c = maximum tsunami height at the coast (from figure 5.9(a) to 5.9(f) as appropriate) (m)

x = distance of the bridge site from the coast (m)

L = distance from the coast at which the maximum run-up elevation is reached (m)

H_b = elevation of the ground surface or pre-tsunami water level at the bridge site (m)

The tsunami flow velocity of the bore at the bridge shall be assumed to be:

$$V_t = \sqrt{g y_t} \quad (5-53)$$

Where:

g = gravitational acceleration (m/s^2)

y_t = tsunami flow depth at the bridge as defined above (m).

5.8.6 Hydrodynamic forces acting on the bridge Hydrodynamic forces acting on the structure shall be treated as an ultimate limit state load case using load factors for load combination 3E in table 3.2. The forces shall be determined from the equation:

$$F = C_d (0.5 \rho V_t^2 A) \quad (5-54)$$

Where:

C_d = a coefficient to be taken as 4.5 for horizontal loading, and, for vertical loading, either 3.0 for vertically upward loading or the appropriate negative value from figure 15.4.3 in AS 5100.2 *Bridge design part 2 Design loads*⁽³³⁾ for vertically downward loading

ρ = the density of the flowing tsunami water, to be taken as 1.100 tonne/m^3 unless sediment entrainment is unlikely (tonne/m^3)

V_t = the tsunami horizontal flow velocity at the bridge (m/s)

A = the projected surface area of the bridge onto a vertical plane perpendicular to the flow in the case of the horizontal force applied to the bridge, or onto a horizontal plane in the case of the vertical uplift force or downward force applied to the bridge (m^2).

5.8.6 continued

Horizontal and vertical loadings shall be treated as concurrent. Vertically upward loadings shall be treated as non-concurrent with vertically downward loadings. The eccentricity of loadings on the superstructure relative to reactions at the supports, inducing moments in the superstructure, shall be taken into account.

Where inland flow of the tsunami may carry debris and lodge a debris raft against the bridge the size of debris raft to be allowed for shall be determined in accordance with 2.3.

5.8.7 Bridge scour

Scour effects on the bridge foundations shall be assessed based on 2.3 using the bore flow depth and velocity at the bridge.

Figure 5.9(a): Tsunami height (maximum amplitude) in metres at 50th percentile (2500 year return period)

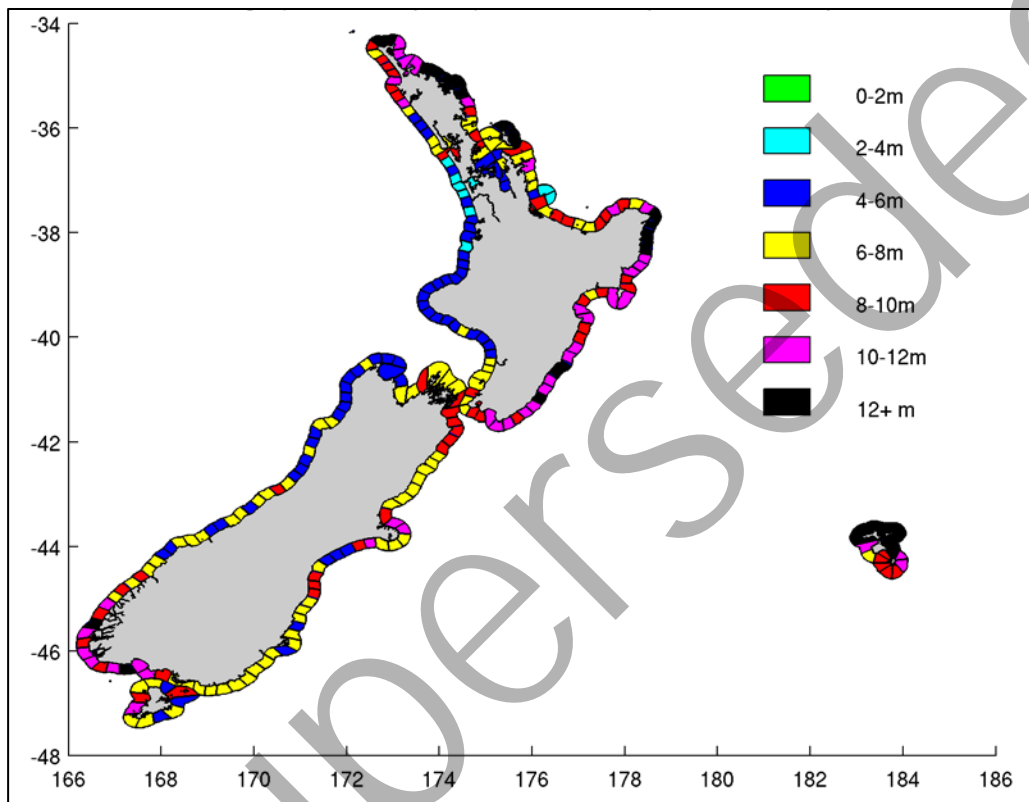

Figure 5.9(b): Tsunami height (maximum amplitude) in metres at 50th percentile (1000 year return period)

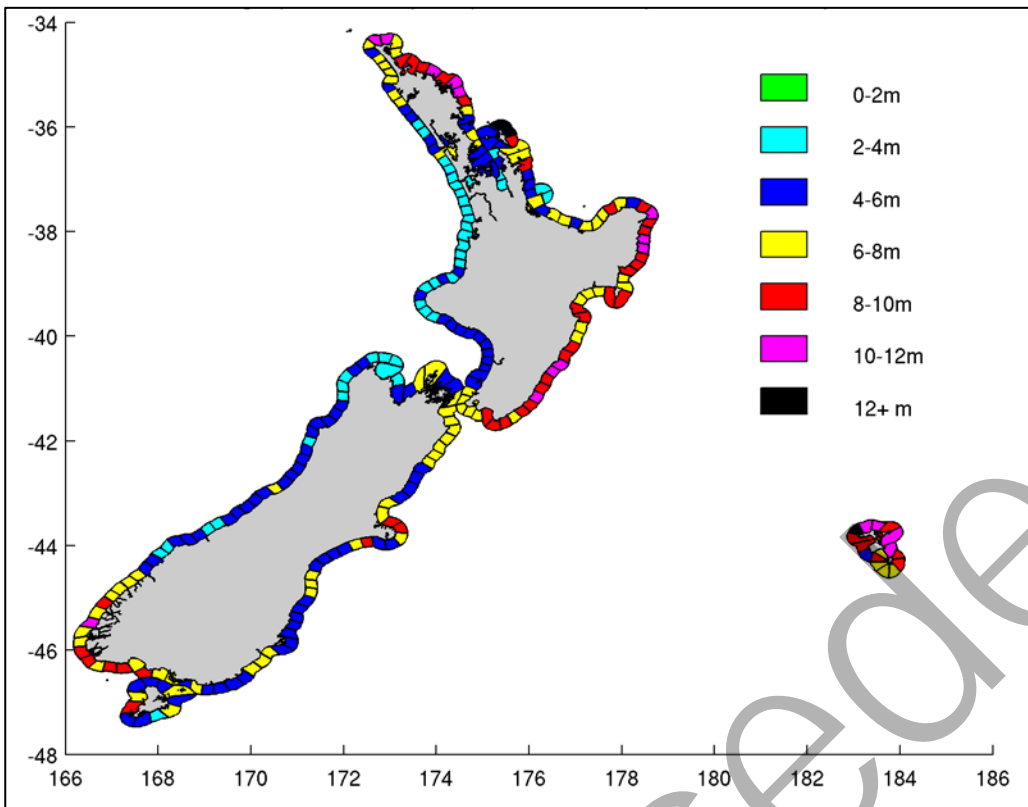

Figure 5.9(c): Tsunami height (maximum amplitude) in metres at 50th percentile (500 year return period)

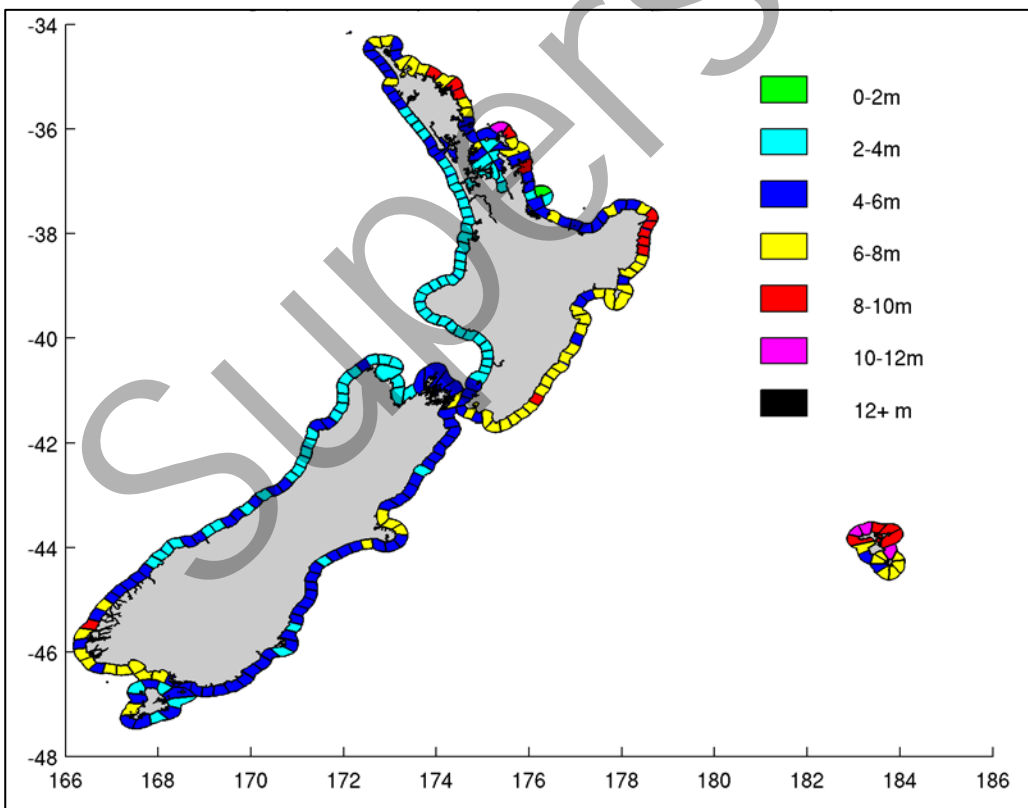

Figure 5.9(d): Tsunami height (maximum amplitude) in metres at 50th percentile (250 year return period)

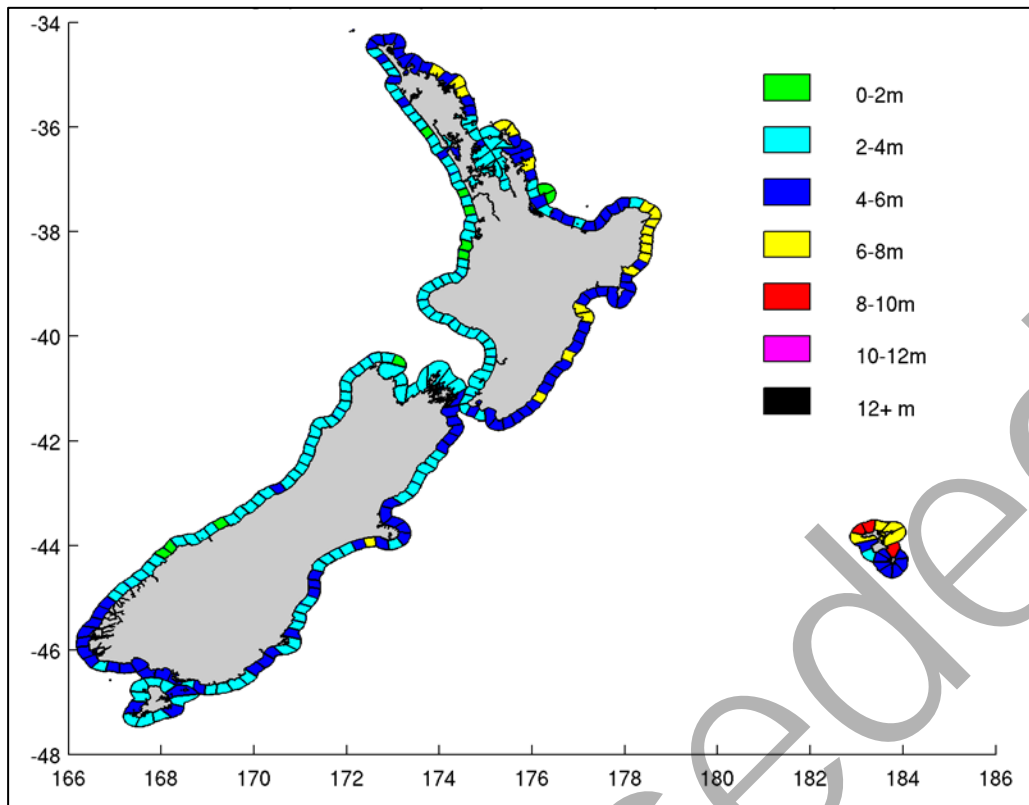

Figure 5.9(e): Tsunami height (maximum amplitude) in metres at 50th percentile (100 year return period)

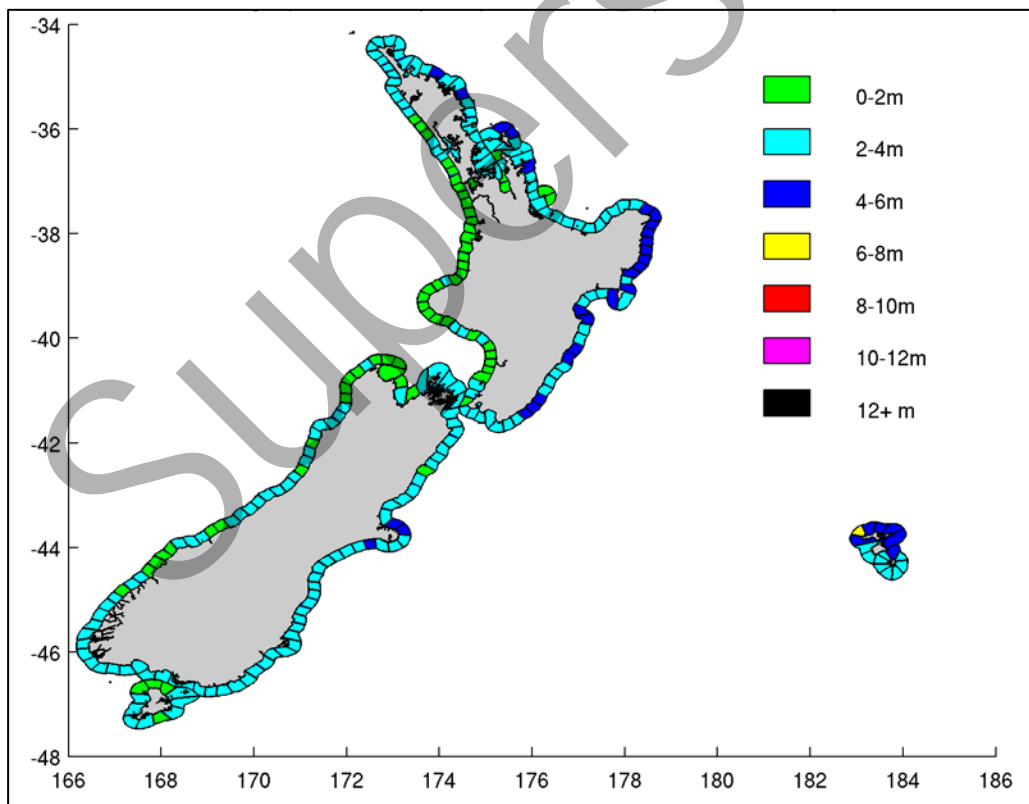
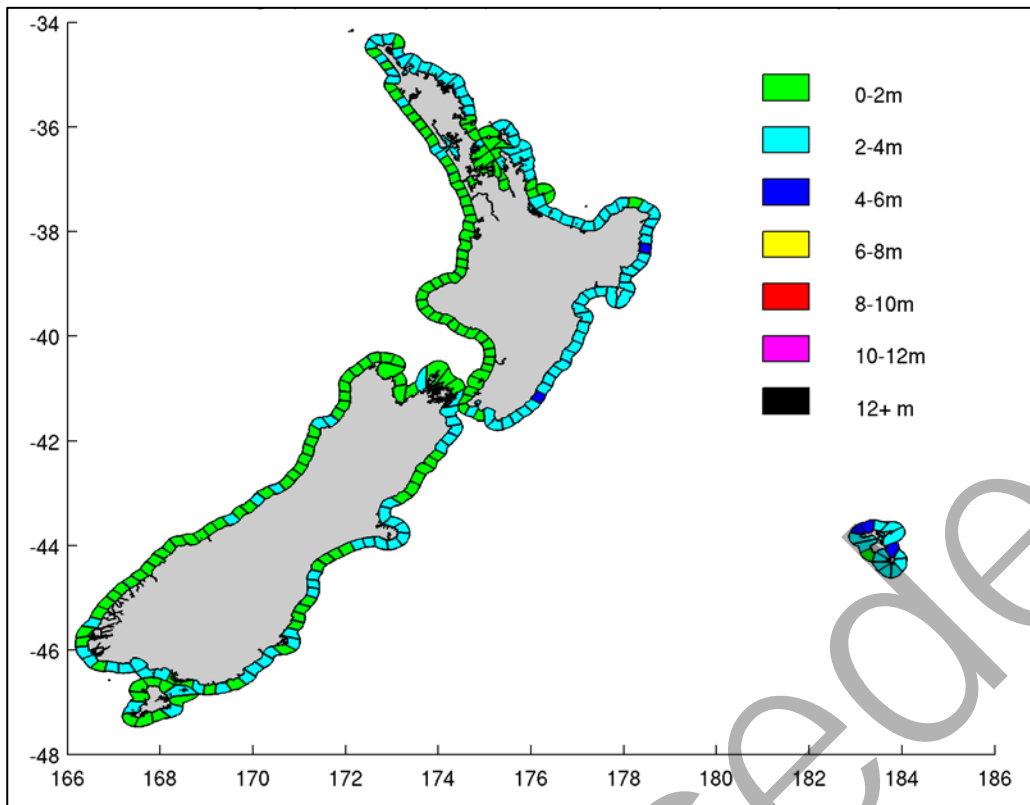

Figure 5.9(f): Tsunami height (maximum amplitude) in metres at 50th percentile (50 year return period)



Superseded

5.9 References

- (1) Standards New Zealand NZS 1170.5:2004 *Structural design actions*. Part 5 Earthquake actions – New Zealand. (Incorporating Amendment No. 1: 2016)
- (2) Standards New Zealand NZS 3101.1&2:2006 *Concrete structures standard*. (Incorporating Amendment No. 3: 2017)
- (3) Standards New Zealand NZS 3404 Parts 1 and 2:1997 *Steel structures standard*.
- (4) Standards Australia and Standards New Zealand jointly AS/NZS 1170.0:2002 *Structural design actions*. Part 0 General principles.
- (5) Priestley MJN, Seible F and Calvi GM (1996) *Seismic design and retrofit of bridges*. John Wiley & Sons Inc., New York, NY, USA.
- (6) Priestley MJN, Calvi GM and Kowalski MJ (2007) *Displacement-based seismic design of structures*. IUSS Press, Pavia, Italy.
- (7) Standards New Zealand NZS 1170.5 Supplement 1:2004 *Structural design actions*. Part 5 Earthquake actions – New Zealand Commentary. (Incorporating Amendment No. 1: 2016)
- (8) New Zealand Society for Earthquake Engineering and Ministry of Business, Innovation & Employment (2017) *New Zealand Seismic isolation guidelines*. (In prep.)
- (9) Stirling M et al (2000) *Probabilistic seismic hazard assessment of New Zealand: New active fault data, seismicity data, attenuation relationships and methods*. Client Report 2000/53 prepared for the Earthquake Commission Research Foundation, Institute of Geological and Nuclear Science, Lower Hutt.
- (10) Stirling MW (2000) *New national probabilistic seismic hazard maps for New Zealand*. Proceedings 12th World Conference on Earthquake Engineering, Auckland.
- (11) Stirling MW, McVerry GH, and Berryman KR (2002) *A new seismic hazard model for New Zealand*. Bulletin of the Seismological Society of America, Vol. 92, No. 5.
- (12) McVerry GH (2003) *From hazard maps to code spectra for New Zealand*. Proceedings 7th Pacific Conference on Earthquake Engineering, Christchurch.
- (13) McVerry GH, Zhao JX, Abrahamson NA, and Somerville PG (2006) *New Zealand acceleration response spectrum attenuation relations for crustal and subduction zone earthquakes*. Bulletin of the New Zealand Society for Earthquake Engineering, vol. 39, no. 1.
- (14) Stirling MW, McVerry GH and Gerstenberger M (2012) *New national seismic hazard model for New Zealand: Changes to estimated long-term hazard*. 2012 NZSEE Annual Technical Conference, Christchurch.
- (15) Stirling M et al (2012) *National seismic hazard model for New Zealand: 2010 update*. Bulletin of the Seismological Society of America, vol. 102, no. 4.
- (16) Priestley MJN, Park R and Heng NK (1979) *Influence of foundation on the seismic response of bridge piers*. Bulletin of the New Zealand Society for Earthquake Engineering, vol. 12, no. 1.

- (17) Wood JH (2012) *Performance of linkage bars for restraint of bridge spans in earthquakes*. Report to New Zealand Transport Agency, Wellington.
- (18) O'Rourke MJ and Liu X (2012) *Seismic design of buried and offshore pipelines*. MCEER-12-MN04, University at Buffalo, State University of New York, NY USA.
- (19) Newmark NM (1967) *Problems in wave propagation in soil and rocks*. Proceedings of the International Symposium on Wave Propagation and Dynamic Properties of Earth Materials, University of New Mexico Press.
- (20) American Association of State Highway and Transportation Officials (2011) *Guide specifications for LRFD seismic bridge design*. 2nd edition. Washington DC, USA.
- (21) Society of Structural Engineers Gen-Col. Last accessed 28 September 2018. <www.sesoc.org.nz/software/>. (Available to members only.)
- (22) Standards Australia and Standards New Zealand jointly AS/NZS 5100.6:2017 *Bridge design*. Part 6 Steel and composite construction.
- (23) Standards Australia and Standards New Zealand jointly AS/NZS 1554.3: 2014 *Structural steel welding*. Part 3 Welding of reinforcing steel.
- (24) Ministry of Business, Innovation & Employment (2006) Practice Advisory 8: *Don't be undone – anchor your spiral*. Wellington.
- (25) Wood JH (2007) *Earthquake design of rectangular underground structures*. Bulletin of the New Zealand Society for Earthquake Engineering, vol. 40, no.1.
- (26) British Standards Institution BS EN 1994. _____ *Eurocode 4 Design of composite steel and concrete structures*.
Part 1-1:2004 General rules and rules for buildings
Part 2:2005 General rules and rules for bridges.
- (27) Standards New Zealand NZS 3404.1:2009 *Steel structures standard*. Part 1 Materials, fabrication, and construction. Withdrawn.
- (28) Chapman HE and Kirkcaldie DK (1990) *Seismic design of base isolated bridges incorporating mechanical energy dissipators*. Road Research Unit Bulletin 84, Volume 3. NZ Transport Agency, Wellington.
- (29) American Association of State Highway and Transportation Officials (2010) *Guide specifications for seismic isolation design*, 3rd edition. Washington DC, USA.
- (30) Melville B, Shamseldin A, Shafiei S, and Adams K (2014) *Outline for designing bridges that may be subjected to tsunami loads*. Stage 1 Literature review: New Zealand's exposure to tsunami hazard, bridge failure mechanisms and existing design guidelines. University of Auckland.
- (31) Melville B, Adams K, Shafiei S, and Shamseldin A (2015) *Outline for designing bridges that may be subjected to tsunami loads*. Stage 2 Draft requirements for the consideration of tsunami effects on bridges. University of Auckland.
- (32) Power W (2013) *Review of tsunami hazard in New Zealand (2013 update)*. GNS Science Consultancy Report 2013/131. Lower Hutt.
- (33) Standards Australia AS 5100.2:2017 *Bridge design*. Part 2 Design loads.

6.0 Site stability, foundations, earthworks and retaining walls

In this section	Section	Page	
	6.1	Scope and performance requirements	6-2
	6.2	Design loadings and analysis	6-6
	6.3	Earthquake induced liquefaction, slope instability and ground deformation	6-19
	6.4	Design of earthworks	6-29
	6.5	Foundations	6-32
	6.6	Earth retaining systems	6-34
	6.7	Geofoam road embankments	6-45
	6.8	Geosynthetic soil reinforcement	6-45
	6.9	References	6-48

6.1 Scope and performance requirements

6.1.1 General

This section presents design philosophy and design criteria for the:

- assessment of slope stability, liquefaction and lateral spreading in earthquakes
- design of mitigation measures for liquefaction and slope instability
- design of foundations
- design of embankments and cut and fill slopes
- design of earth retaining structures including mechanically stabilised earth (MSE).

It includes assessment and design under both non-seismic conditions and earthquake shaking and specifies minimum post-earthquake performance standards.

Acceptable methods of assessment are stated within this section. Alternative methods may be adopted subject to road controlling authority acceptance, but shall be suitably established, internationally recognised, widely used methods and shall be noted in the earthworks design report, structure options report or structure design statement.

The term "soil structures" used in this section includes cut and fill slopes (including stabilised slopes), embankments, retaining walls and earth retaining structures (including MSE).

The term "bridge" shall include bridges, major sign gantries and major culverts.

In this manual, as well as the serviceability limit state, the terminology adopted for the limit states relevant to earthquake resistance are the damage control limit state and the collapse avoidance limit state as outlined in 5.1.1.

6.1.2 Performance requirements

a. Settlement and displacement limits

Settlement and displacement limits that shall be applied to the performance of bridges and soil structures are given in table 6.1. The maximum settlement and horizontal displacement limits apply to the total cumulative settlements and displacements due to all actions including static soil pressures, inertial response to seismic actions, and ground movement due to liquefaction and/or slope instability.

In addition to the settlement limits, bridges shall also satisfy the performance requirements of 5.1.2 and 6.1.2(c), which may be more limiting.

The effects of 200% of the seismic displacement arising from one damage control limit state (DCLS) design intensity earthquake and, separately, of a collapse avoidance limit state (CALS) event displacement on any affected bridge structures shall be assessed and compared against the performance criteria specified in 5.1.2(c) for the CALS major earthquake event.

b. Serviceability limit state following a seismic event

Soil structures shall satisfy the following serviceability limit state requirements:

- i. Where the serviceability of structures (bridges, major culverts, major sign gantries, etc) is dependent on, or influenced by associated or adjacent soil structures, the soil structures shall be designed to ensure that their performance does not deleteriously affect the structure from satisfying its serviceability requirements, as specified elsewhere within this manual.
- ii. All soil structures associated with roads shall remain undamaged with no detriment to the road following earthquake events with an annual exceedance probability of 1/25.

Table 6.1: Total settlement, differential settlement and horizontal displacement limits

Structure, wall and slope scenario	Structure, retaining structure and slope type	SLS load combinations (including seismic events detailed in 6.1.2(b)(iii))		DCLS load combinations		
		Maximum total settlement	Maximum differential settlement	Maximum total settlement	Maximum differential settlement	Maximum total horizontal displacement*
Simply supported bridge	All types	Refer to 2.1.8 [†]		100mm [†]	1/300 [†]	N/A
Continuous bridge	All types			Z < 0.4: 40mm ^{†‡}	1/500 [†]	N/A
Soil structure supporting or containing bridge abutments or piers	All types	As per bridge structure [†]				Z < 0.3: 25mm [‡] 0.3 ≤ Z < 0.4: 50mm [‡] Z ≥ 0.4: 100mm [‡]
Soil structures above road level supporting structures belonging to other parties within 2H [§] of any wall face at the top of the wall or bottom of the slope	All types	30mm	1/500	Refer to table 6.2		25mm
Soil structures supporting road carriageway with AADT** ≥ 2500	Rigid wall	50mm [†]	1/500 [†]	Refer to table 6.2		100mm
	Flexible wall or slope capable of displacing without structural damage	50mm ^{††}	1/100 ^{††}			150mm
Soil structures supporting road carriageway with AADT < 2500	Rigid wall	50mm [†]	1/300 [†]	Refer to table 6.2		100mm
	Flexible wall or slope capable of displacing without structural damage	50mm ^{††}	1/100 ^{††}			200mm

Notes:

- * The designer shall ensure that the displacements will not cause damage to adjacent structures or services.
- † Any settlement of bridges or rigid walls occurring prior to pilecap or foundation construction may be neglected.
- ‡ Subject to also satisfying the requirements of 6.6.9(b).
- § H is the height of the retaining structure including the height of any slope above, or the height of the slope.
- ** AADT is the annual average daily traffic count.
- †† Any settlement of flexible walls or slopes occurring prior to pavement construction or utilities installation may be neglected.

6.1.2 continued

- iii. The operational continuity of routes shall not be significantly impeded following earthquake events of relatively high annual exceedance probabilities. The road controlling authority shall be consulted and should define the operational performance expectations for the section of road to be designed, taking into consideration the redundancy in the regional road network, and the resilience required for the proposed road to ensure the desired functionality of the road network. This should provide the access resilience expectations in terms of degree of access required on the road after different levels of events and the time for restoration of access.

The following default values are provided in the absence of such considered definition:

- o 1/100 for routes of importance level 4, importance level 3+ and importance level 3 (see tables 2.2 and 2.3)
- o 1/50 for routes of importance level 2
- o 1/25 for minor routes of importance level 1.

Operational continuity is defined as:

- o full live load capacity is maintained
- o the road shall be useable by emergency traffic (as defined in 5.1.2)
- o full vehicle access is restorable within 24 hours
- o any necessary repairs shall be of such a nature that they can be completed within one month.

- c. Damage control limit state following a seismic event

Soil structures not affecting bridges or major culverts shall satisfy the performance requirements given in table 6.2 when subjected to their design annual probability of exceedance earthquake event.

Soil structures affecting bridges or major culverts shall be designed to ensure that their performance does not deleteriously affect the structure from satisfying the requirements of 6.1.2(a).

Table 6.2: Seismic performance requirements for soil structures not affecting bridges after a design (DCLS) event

Post-earthquake - immediate	Slope stability factor of safety (FoS) > 1.1 for post-seismic stability with residual shear strengths and zero peak ground acceleration
Post-earthquake function - short term	Usable by emergency traffic (as defined in 5.1.2) and capable of supporting two lanes of HN (normal) loading with a slope stability FoS > 1.3 under static strength conditions
Post-earthquake function - after reinstatement	Feasible to reinstate for all design (ULS/DCLS) level actions
Acceptable damage	<p>a. Damage possible: capable of permanent repair.</p> <p>b. The detailing of barriers, foundations formed within or upon soil structures and facing panels should be such that the predicted DCLS displacements do not result in damage to these elements beyond repair. Necessary reinstatement works should be limited to removal of facing panels and barriers, reconstruction of panel footings, reinstatement of barriers and panels to original levels or other lesser level acceptable to the road controlling authority and reconstruction of road pavement.</p>

6.1.2 continued

In addition to the structure performance requirements of 5.1.2 the following performance requirements shall also be met by structures exposed to the effects of liquefaction and site instability resulting from a damage control limit state design intensity earthquake:

- i. the design specified required clearances over underlying roads, railway lines and design flood levels shall be maintained or be able to be readily reinstated without deleteriously affecting the functioning of underlying infrastructure
 - ii. an acceptable quality of road surface rideability and vertical alignment, suitable for the design speed of the road, shall be maintained or be able to be readily reinstated. Any application of an overlay shall not reduce the structure's live load capacity to below the specified required design live load capacity or erode the performance of concrete barrier systems that have been constructed integral with the bridge deck
 - iii. the movement capacity of elements of the structure designed to accommodate seismic, thermal, and shrinkage and creep movements within the structure shall retain or be able to readily have reinstated sufficient movement capacity to accommodate the movements due to one further damage control limit state design intensity earthquake in addition to the design movements due to thermal, shrinkage and creep effects.
- d. Departures from the specified standards

Where settlement and/or horizontal displacement limits are impractical or uneconomic to satisfy, or where the cost of ground improvement or other mitigation measures is very high in comparison with the project or structure cost, consideration should be given to making a request to the road controlling authority for accepting a lower design standard. Factors to be taken into account in making this request include:

- the route importance
- the value of the structure
- the likelihood and extent of disruption to the route and the consequences of the route disruption
- the ground improvement or other mitigation cost
- the extent to which the performance requirements will be satisfied by the proposed solution
- consequences of lower design standards and poorer performance of the structure.

In making a request for a lower design standard it should be noted that any compromise on the requirement for a structure to not collapse after a CALS major earthquake event (see 5.1.2(c)) is unlikely to be accepted.

Where a departure request involves displacements of structures or parts of structures exceeding the specified standards, there is likely to be a requirement that:

- the superstructure remains elastic in the design (DCLS) seismic event
- the superstructure is able to be jacked and relevelled to the original design levels
- major reconstruction of primary substructure elements shall not be required
- after the earthquake event, the bridge shall be usable by emergency traffic (as defined on 5.1.2)
- after reinstatement, the design level actions to be accommodated shall include the effects of any permanent deformation of the structure.

6.2 Design loadings and analysis

6.2.1 General

Design loads to be considered shall be as specified in section 3 of this manual. In particular, earth loads are specified in 3.4.12 and load combinations in 3.5.

6.2.2 Earthquake loads and analysis for the assessment of liquefaction and of the stability and displacement of soil structures

The design earthquake loading to be applied to soils, rock and independent soil structures shall be derived as set out herein.

Methods for the assessment of liquefaction, slope stability, and soil structure displacements referred to within this section require the application of peak ground accelerations in combination with a corresponding earthquake magnitude. The peak ground accelerations (PGA) to be applied shall be 'unweighted' and derived for the relevant return period as follows:

$$PGA = C_{0,1000} \times \frac{R_u}{1.3} \times f \times g$$

Where:

$C_{0,1000}$ = 1000 year return period PGA coefficient for a subsoil Class A or B rock site or Class C shallow soil site derived from figure 6.1(a), or for subsoil Class D deep or soft soil site or Class E very soft soil site from figure 6.1(b). Alternatively, for the locations listed, PGA coefficients may be taken from table C6.1 contained in C6 in the *Bridge manual commentary*

R_u = DCLS return period factor derived from table 3.5 of NZS 1170.5 *Structural design actions part 5 Earthquake actions - New Zealand*⁽¹⁾, or table 5.3 of this manual as appropriate, corresponding to the design return period determined from tables 2.2 or 2.3, as appropriate (see 5.2.2(b))

f = Site subsoil class factor, where

$f = 1.0$ for a Class A, B, D and E soil sites

$f = 1.33$ for a Class C shallow soil site

The earthquake magnitude shall be derived for the relevant return period from figures 6.2(a) to (f) or table C6.1 contained in C6 in the *Bridge manual commentary**

As a lower bound, the damage control limit state effects to be designed for shall not be taken to be less than those due to a 6.5 magnitude earthquake at 20km distance, for which the peak ground acceleration coefficients shall be derived from table 6.3.

Table 6.3: Peak ground acceleration coefficients corresponding to a magnitude 6.5 earthquake at 20 km distance

Site subsoil class	Class A/B rock	Class C shallow soil	Class D deep or soft soil	Class E very soft soil
PGA coefficient (g)	0.14	0.19	0.16	0.16

Note that PGAs derived using NZS 1170.5⁽¹⁾ are magnitude weighted to correspond to an earthquake magnitude of 7.5. Given that the performance of soils, earth structures, slopes and retaining walls exhibit a step-wise behaviour (where a critical acceleration results in a sudden loss of stability, ie dramatic change in behaviour), use of these values may be unconservative. Therefore unweighted PGAs are to be used in the assessment and design of these soil structures for earthquakes.

* The relationship between PGAs and effective magnitudes is under review. Consequently the figure 6.2 series of maps have not yet been updated to reflect all return periods in tables 2.1 to 2.3. Table C6.1 should therefore be used where necessary as an interim measure.

6.2.2 continued

Unweighted PGAs are to be derived as specified herein. They are not to be back-calculated from NZS 1170.5⁽¹⁾ magnitude weighted PGAs as doing so will give rise to inconsistencies due to the approximations that are inherent in the NZS 1170.5⁽¹⁾ site hazard spectra.

Caution should be exercised in the use of the effective magnitudes from figures 6.2(a) to (f) or table C6.1 contained in C6 in the *Bridge manual commentary* as appropriately matching peak ground accelerations with earthquake magnitudes, representing the duration of shaking, lacks precision. Peak ground accelerations attenuate rapidly with distance and so their estimation is influenced most by local sources. Shaking duration may often be indicated in spectra by longer period components of motion, which are often contributed to most by larger magnitude more distant earthquakes.

For liquefaction analysis, an earthquake magnitude should be used in combination with the PGA.

Dependent on the value of the project soil structures and earthworks to be designed for earthquake resistance, a site specific seismic hazard study shall be undertaken as a special study, as follows:

- less than \$3.2 million - a site specific seismic hazard study is not required
- \$3.2 million to \$7.5 million - a site specific seismic hazard study is advisable
- more than \$7.5 million - a site specific seismic hazard study is mandatory (values at June 2018^{*})

Where the site is formed by potentially liquefiable materials, NZTA may instruct the designer to carry out a site specific seismic hazard study for projects with values of less than \$7.5 million, especially for soil structures with importance levels 3 and 4.

Deaggregation of seismic hazard shall be carried out as part of a site specific seismic study. The individual sources contributing the most to the seismic hazard of the site should be considered. The PGA and magnitude values representing realistic ground motions that could actually occur at the site due to known active faults in the area should be used in the assessment of liquefaction. This process may yield more than one magnitude-PGA pair for liquefaction analysis in some areas of New Zealand. Each magnitude-PGA pair should be evaluated individually in the liquefaction analysis. If liquefaction is estimated for any given magnitude-PGA pair, the evaluation of that pair should be continued through the slope stability and lateral deformation evaluation processes.

The effects to be designed for shall not be less severe than those due to the lower bound event of a magnitude 6.5 earthquake at 20km distance.

Where site specific seismic hazard studies are undertaken as permitted or required for any of the cases described above, such studies shall comply with the requirements of 5.2.5, except that magnitude weighting shall not be applied.

Loads derived in accordance with this clause are also applicable to the design of MSE walls and slopes for both their external and internal stability and for the design of their facing panels.

Bridge foundations and soil structures shall be checked for stability using the relevant damage control limit state load combinations specified in table 3.2 and the appropriate strength reduction factors.

* Values shall be adjusted to current value. For the relevant cost adjustment factor refer to the NZTA's *Procurement manual*, Procurement manual tools, Latest values for 1991 infrastructure cost indexes, NZ Transport Agency Construction index⁽²⁾

6.2.2 continued

The stability of the supporting ground to bridge structures (either slopes or retained ground) shall be such that:

- the performance requirements specified in 5.1.2 for a minor earthquake, a design level earthquake and a major earthquake are satisfied
- the collapse of bridge structures is avoided under a collapse avoidance limit state (CALS) event.

Where a site specific seismic hazard study has been undertaken, the magnitude associated with maximum considered motions (ie those associated with 1.5 times the design peak ground accelerations derived as above) shall be adopted as the CALS event. In the absence of such a study, the figure shown in the relevant coloured region of figure 6.3 shall be adopted as the default CALS event magnitude to be used in conjunction with 1.5 times the design peak ground accelerations.

For the assessment of the seismic performance of soil structures, and in the assessment of liquefaction potential, a structural performance factor (S_p) or any other reduction factor shall not be applied to the design earthquake loads unless otherwise specified herein.

Where time-history analysis is applied to the analysis of the response of features and structures falling within the scope of this section 6, the requirements pertaining to the application of time-history analysis set out in 5.3.11(d) shall be complied with.

6.2.3 Design earthquake loads for the structural design of earth retaining structures

- a. Design earthquake loads given in this clause should not be used for the assessment of liquefaction, lateral spreading, deep-seated instability, seismic settlements and displacements of soil structures. Seismic loads for these cases are given in 6.2.2.

For the structural design of earth retaining structures comprised of concrete, steel or timber elements, the design horizontal ground acceleration to be used in computing seismic inertia forces of non-integral abutments and independent walls and of the soil acting against them shall be as follows:

$$\text{Design acceleration } C_o g = C_h(T_0) Z R_u g$$

Where:

C_o = design ground acceleration coefficient

g = acceleration due to gravity

$C_h(T_0)$ = spectral shape factor at $T=0$ from NZS 1170.5⁽¹⁾ table 3.2, (given in brackets in the table), for the appropriate site subsoil category

Z = hazard factor, determined from 5.2.2 and NZS 1170.5⁽¹⁾ clause 3.1.5

R_u = DCLS return period factor from 5.2.2(b)

For the damage control limit state, the product $Z R_u$ shall not be taken as less than 0.13.

Non-integral abutments and independent walls are defined in 6.6.1(a).

- b. All structural components of abutments and walls shall have a design strength not less than the forces calculated using the relevant ultimate limit state/damage control limit state load combinations specified in 3.5.

Figure 6.1(a): Unweighted peak ground acceleration coefficients, $C_{0,1000}$, corresponding to a 1000 year return at a subsoil Class A or B rock site or Class C shallow soil site



Note: For Class C sites a scale factor of $f=1.33$ needs to be applied to the PGA coefficients derived from this figure.

Figure 6.1(b): Unweighted peak ground acceleration coefficients, $C_{0,1000}$, corresponding to a 1000 year return at a subsoil Class D or E deep or soft soil site

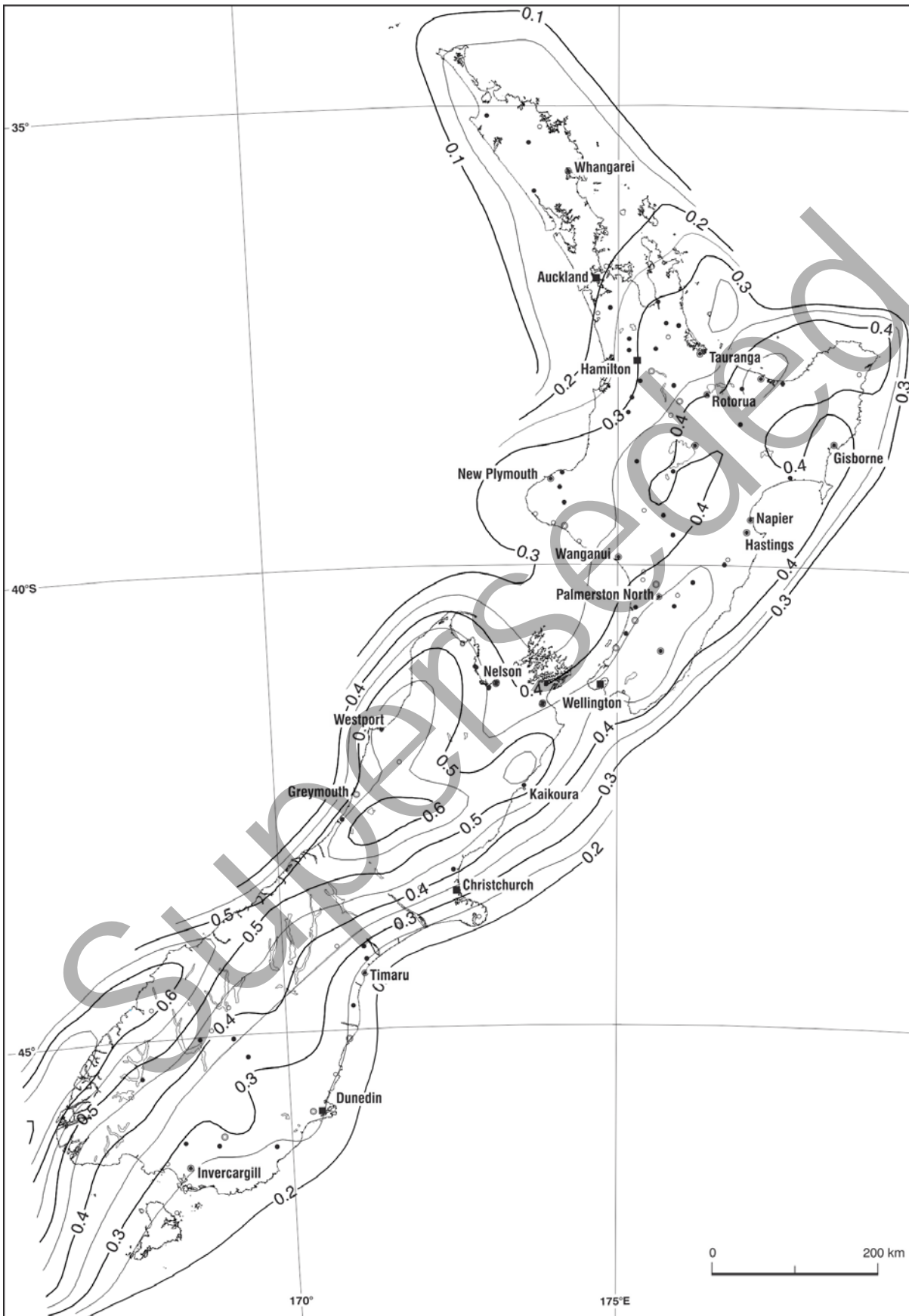

Figure 6.2(a): Effective magnitudes for use with unweighted peak ground accelerations (2500 year return period)

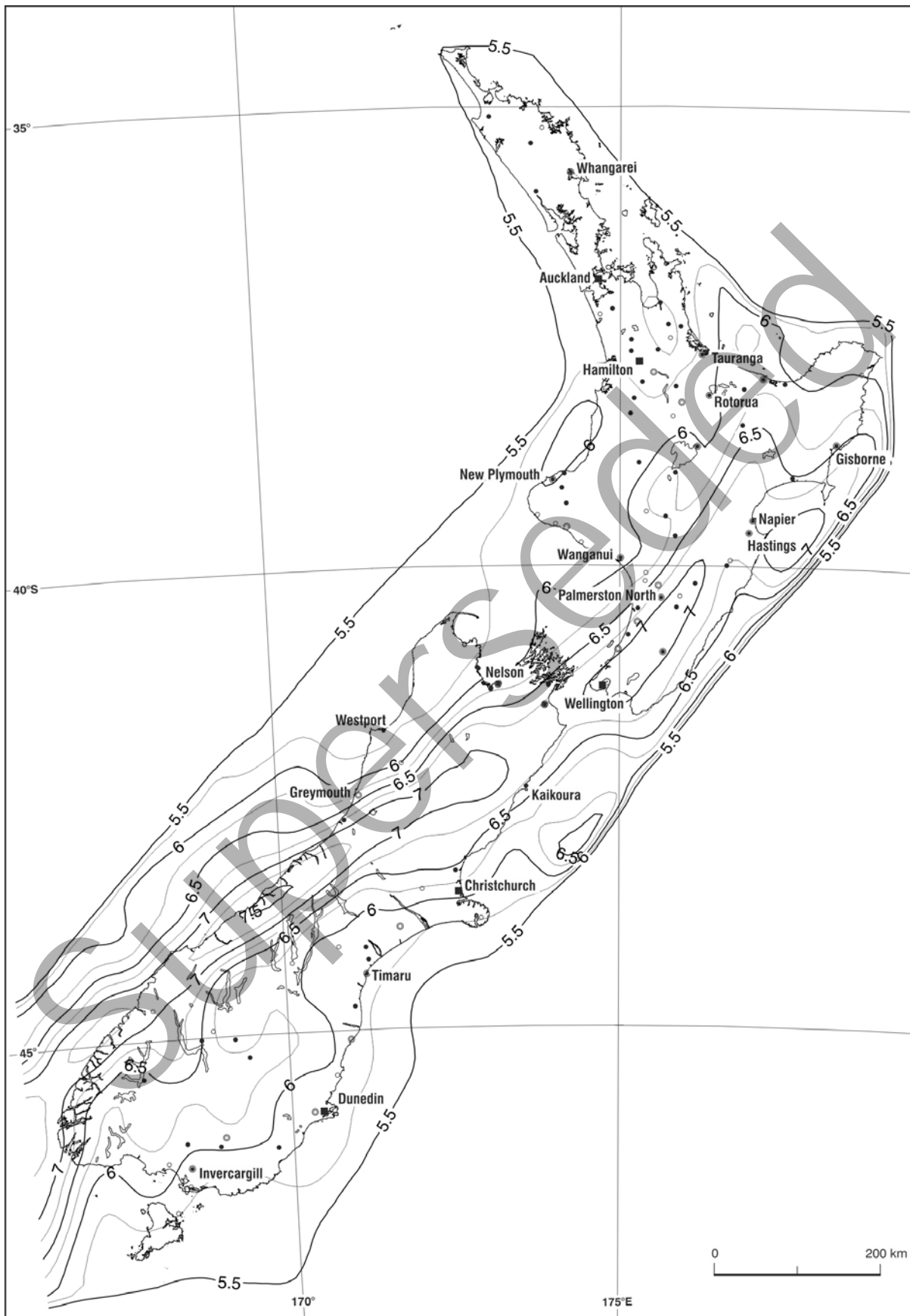

Figure 6.2(b): Effective magnitudes for use with unweighted peak ground accelerations (1500 year return period)

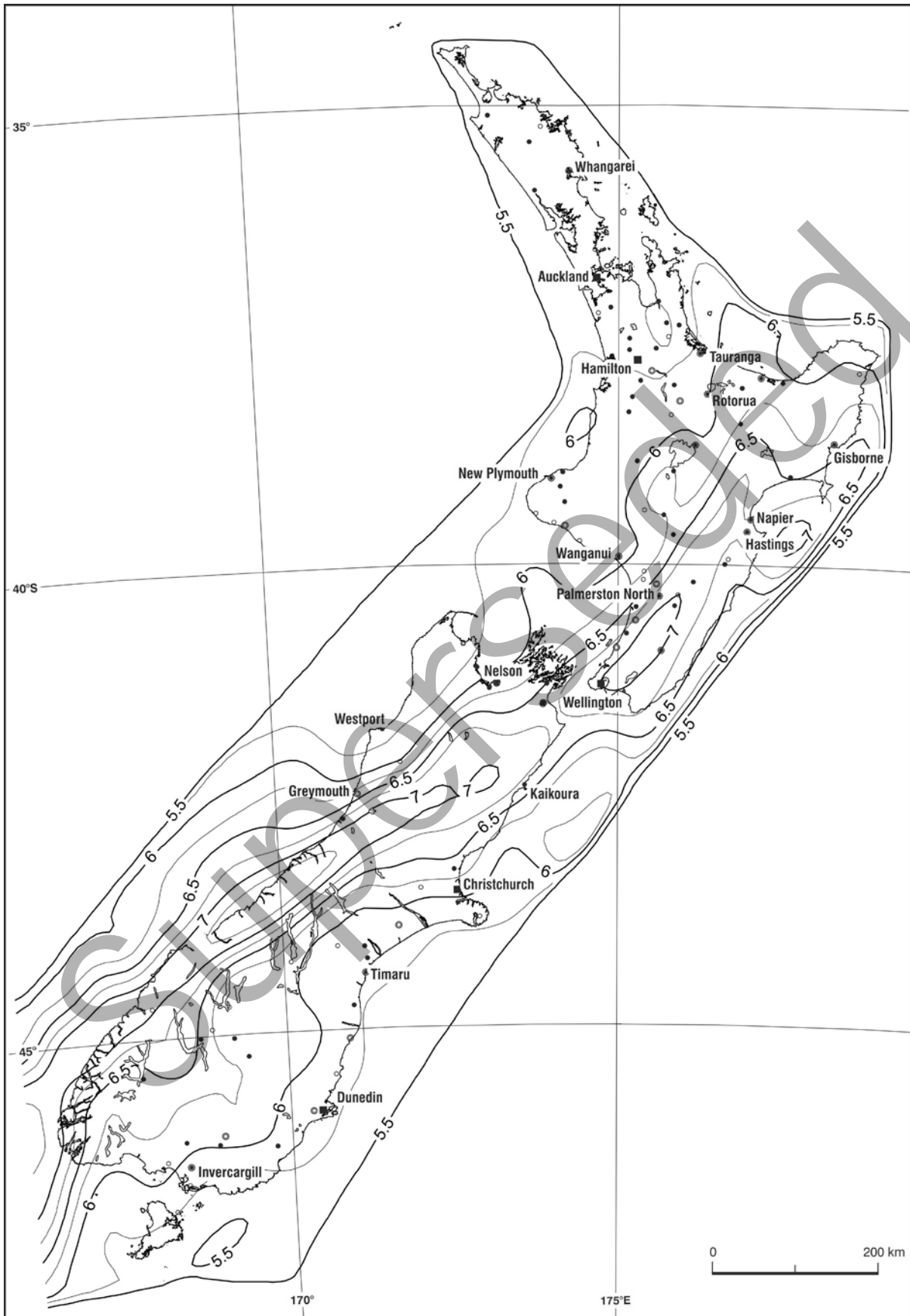

Figure 6.2(c): Effective magnitudes for use with unweighted peak ground accelerations (1000 year return period)

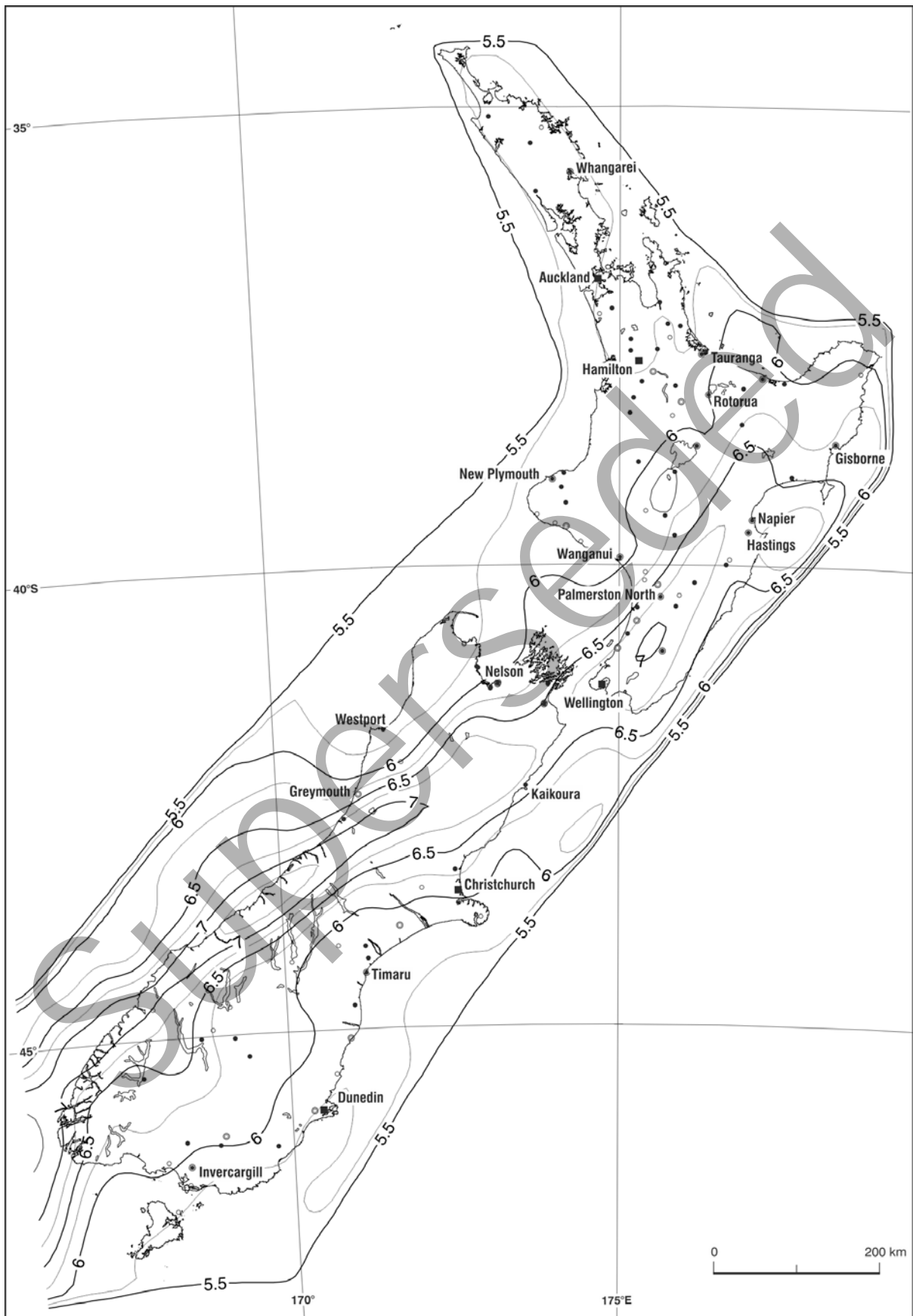

Figure 6.2(d): Effective magnitudes for use with unweighted peak ground accelerations (500 year return period)

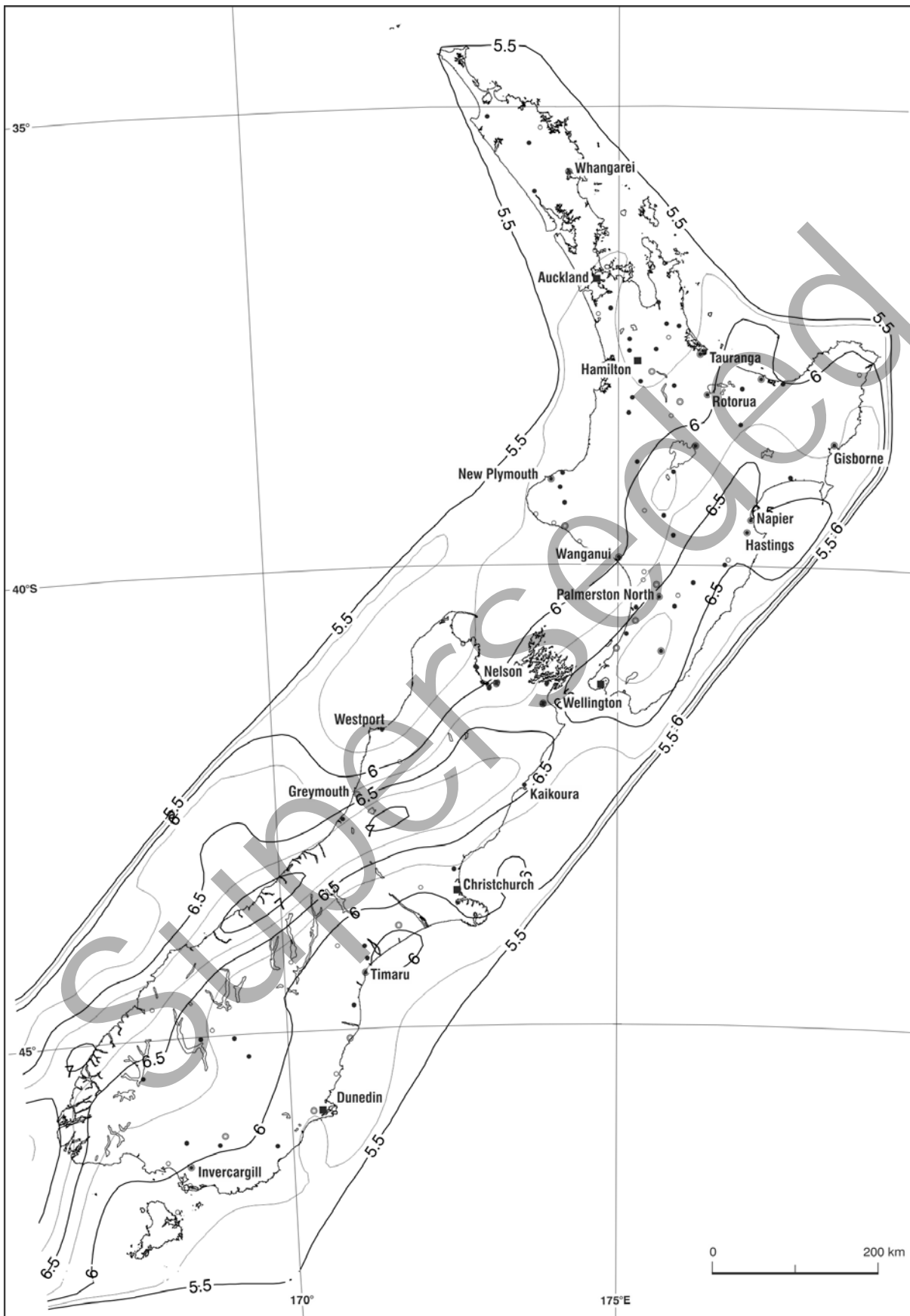

Figure 6.2(e): Effective magnitudes for use with unweighted peak ground accelerations (100 year return period)

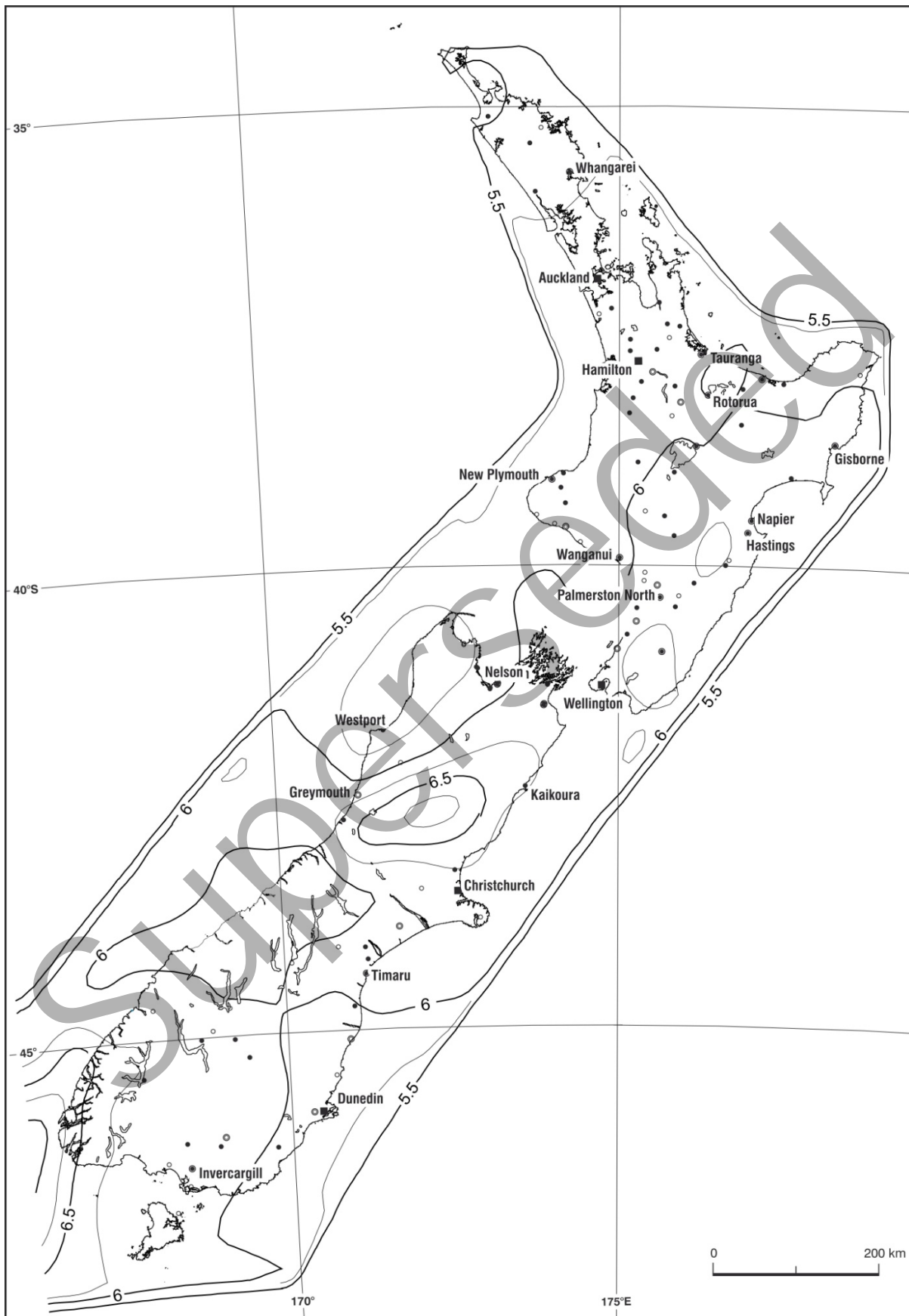

Figure 6.2(f): Effective magnitudes for use with unweighted peak ground accelerations (50 year return period)

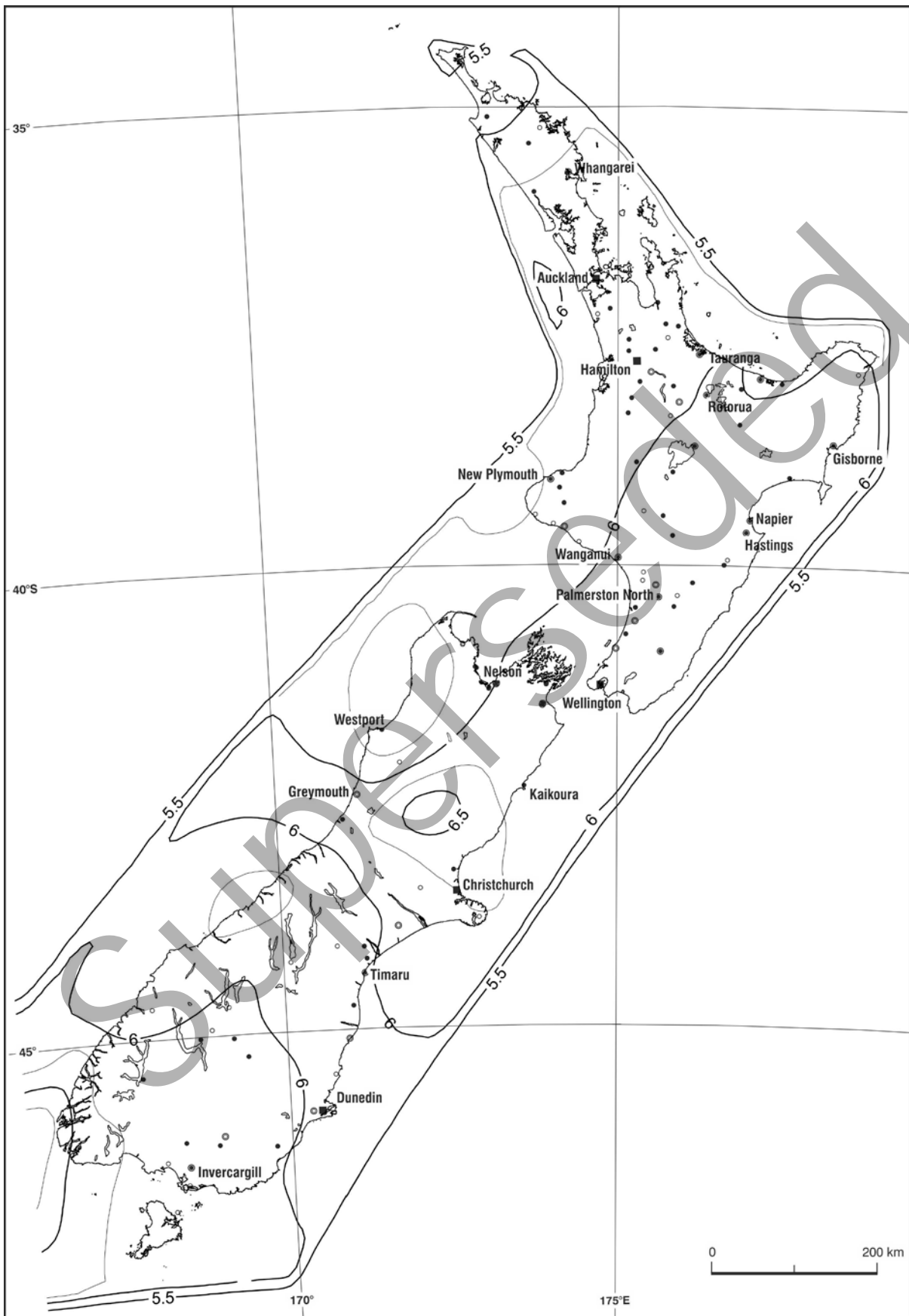
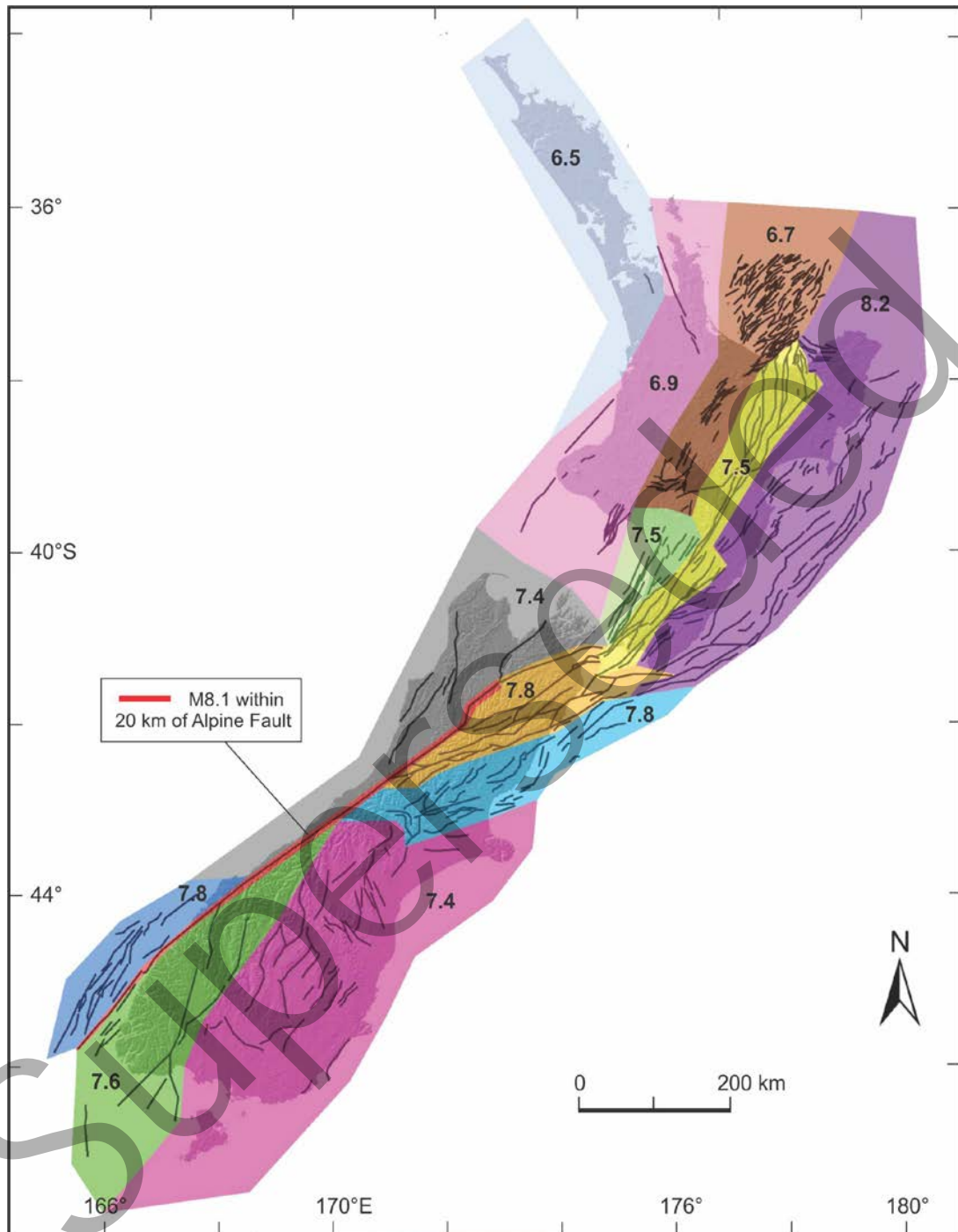

Figure 6.3: Default magnitudes for application in considering bridge structure collapse avoidance in the absence of magnitude deaggregation analysis from a site-specific hazard analysis



Notes:

- (i) Ideally, magnitudes associated with the maximum motions to be considered for collapse avoidance should be derived from deaggregation analyses performed as part of a site specific seismic hazard study. The magnitudes from figure 6.3 shall be used in the absence of such a study.
- (ii) The magnitudes in each region have been derived from consideration of the magnitudes associated with faults in the region that have estimated average recurrence intervals of rupture less than 10,000 years, the approximate return period associated with collapse avoidance for the most important (ie importance level 4) structures. They are likely to be larger than derived from site-specific analyses, especially for structures of lower importance level than importance level 4. The magnitudes may also be lower in locations remote from those faults associated with the magnitudes assigned to the region as a whole.
- (iii) The northern part of the North Island has been assigned the magnitude of 6.5 associated with the event that governs the minimum damage control limit state ZR_u factor of 0.13.

6.2.4 Earth pressures and structure inertia forces on earth retaining structures

The forces discussed in 6.2.4(a) and (b) are illustrated in figure 6.4.

a. The following earth pressure effects shall be taken into account:

P_s - force due to static earth pressure (including compaction force, where appropriate).

ΔP_E - increment or decrement in earth pressure due to earthquake.

P_F - increment of force on wall due to its displacement towards the static backfill (force by the seismic response from a bridge superstructure).

In assessing earth pressure effects, due account shall be taken of the relative stiffnesses of the wall, backfill, foundations and any tie-back anchors.

The earthquake increment of earth pressure (ΔP_E) shall be derived using the 'rigid', 'stiff' or 'flexible' wall pressure distributions, where the wall classifications of 'rigid', 'stiff' or 'flexible' depend on the wall movements, all as given in the Road Research Unit bulletin 84, volume 2 *Seismic design of bridge abutments and retaining walls*⁽³⁾. As recommended in the document, the widely used Mononobe-Okabe earthquake pressure increments shall be used only when there is sufficient wall movement for the wall to be 'flexible'. Passive earth pressure decrements due to earthquake shaking shall be applied for the earthquake load case where passive pressures are relied on to provide stability, and these can be derived using the approach provided in the bulletin.

b. The structural inertia forces to be taken into account shall include:

P_I - The inertia force on the abutment or wall due to ground acceleration acting on the wall, and the soil block above the heel of the wall;

P_B - The force, if any, transmitted between the superstructure and the abutment. This force is the sum of that transmitted by the bearings, and that transmitted by a load limiting device if any.

The force due to sliding bearings shall be calculated assuming the maximum likely friction coefficient. A value of at least 0.15 shall be assumed as specified by 5.3.9(b). The force due to other bearings shall be the product of the total support stiffness and the seismic displacement, Δ . The calculation of Δ shall take account of the relative stiffness of the various supports, and the relative stiffness of the abutment bearings and foundations.

c. The appropriate forces shall be combined as shown in figure 6.4. The structure shown in (a) represents extremes of relative resistance provided by the abutment piles and the backfill. Designs shall take account of intermediate conditions applying as appropriate. In both abutment cases the probability of P_B being out of phase with $\Delta P_E + P_I$ may be taken account of by applying the square root of the sum of the squares of the forces.

6.2.5 Groundwater levels, pressures and effects

Groundwater pressures, and the effect of groundwater on the stability and seismic performance of the site and soil structures, such as liquefaction, shall be considered. These should be based on groundwater levels recorded from site investigations with consideration given to the seasonal fluctuation of groundwater levels; potential for higher groundwater conditions in storm or rainfall events; the fluctuation of groundwater levels with river levels and tidal conditions; artesian water heads; and any potential for changes to groundwater level as a result of the construction or other anticipated changes during the life of the structures or slopes. The effects of climate change or other local changes in the area shall be taken into account together with any regional or local authority recommendations on seasonal groundwater level variation.

Figure 6.4: Seismic force combinations on non-integral abutments and retaining walls

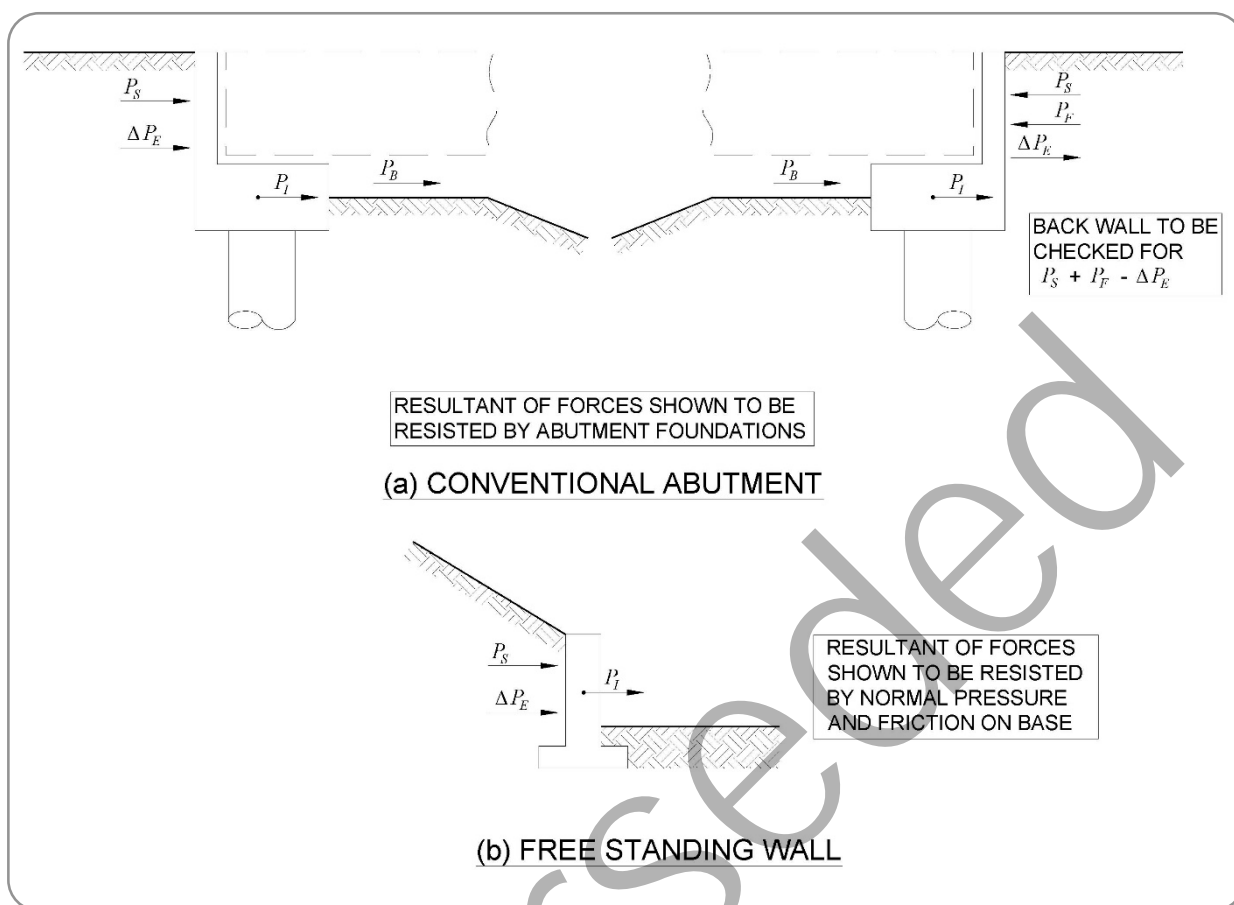

6.3 Earthquake induced liquefaction, slope instability and ground deformation

6.3.1 Causes

Ground rupture, instability and deformation can result from:

- earthquake shaking
- earthquake induced liquefaction or cyclic softening
- lateral spreading with or without associated liquefaction or cyclic softening
- fault rupture associated with earthquakes
- subsidence from other causes, such as groundwater changes, mining, etc. These effects are not considered in this section, but should be assessed where they could occur.

Earthquakes can give rise to ground rupture, slope instability, liquefaction or cyclic softening induced deformation, tectonic movement (subsidence or uplift) and lateral spreading induced subsidence. The potential for such effects to occur, and their effect on the road and the associated structures, should be considered.

Supplementary to the requirements set out in the following clauses, guidance on the design of bridges for liquefaction and lateral spreading effects may be found in NZTA research report 553 *Development of the design guidance for bridges in New Zealand for liquefaction and lateral spreading effects*⁽⁴⁾.

6.3.2 Assessment of slope or land stability in earthquakes

Permanent seismic displacement of soil associated with slope instability and ground movement can occur during earthquakes due to inertial effects associated with ground accelerations and/or weakening of the soil induced by the seismic shear strain.

In many cases, inertial slope instability and ground movement can occur as a result of temporary exceedance of the soil strength by dynamic earthquake stresses, even if there is no substantial reduction in soil strength due to pore pressure build up, liquefaction or soil sensitivity. Instability is mostly the result of soil becoming progressively weaker as shaking occurs such that the soil strength becomes insufficient to maintain a stable slope. Weakening may occur due to factors including shaking, pore pressure build up, liquefaction and sensitive fine grained soils.

Two types of slope instability can occur: flow failure and lateral spreading.

Flow failures are driven by static shear stresses that lead to large deformation or flow. Such failures are characterised by sudden initiation, rapid failure, and the large distances over which the failed materials move. Flow failures typically occur near the end of strong shaking or shortly after shaking. However, delayed flow failures caused by post-earthquake redistribution of pore water pressures can also occur, particularly if liquefiable soils are capped by soil layers with low permeability. Flow ceases only when the driving shear forces are reduced (such as by slope reduction) to values less than the residual shear resistance of the flowing material.

The potential for liquefaction and increased porewater pressure induced flow failures can be evaluated from limit equilibrium slope stability analyses, using residual undrained shear strength parameters for the liquefied soil and zero PGA (ie no seismic inertia loads are applied). Residual liquefied soil strength values for the flow failure analysis can be determined from empirical relationships in NZTA research report 553⁽⁴⁾ or from laboratory test results. If the limit equilibrium factor of safety is less than 1.05, flow failure is considered to be likely.

Lateral spreading can occur when the shear strength of the liquefied soil is incrementally exceeded by the inertial forces induced during an earthquake or when soil strength and stiffness degrade sufficiently to produce substantial permanent strain in the soil. The result of lateral spreading is the horizontal movement of a non-liquefied crust over liquefied soils combined with the movement of liquefied soils themselves. Where the limit equilibrium factor of safety is greater than 1.05 for liquefied conditions and zero PGA, deformation and stability shall be evaluated using a lateral spreading analysis. As opposed to flow failures, lateral spreading analysis directly considers the effect of seismic acceleration.

Potential slope instability and displacements shall be assessed using geotechnical principles, as follows:

- The factor of safety against instability shall be assessed using conventional slope stability analysis with load and strength reduction factors of one, and the seismic coefficient associated with the relevant earthquake accelerations as set out in 6.2.2. Average groundwater conditions or maximum tide levels should be assumed for this assessment.
- If the factor of safety is less than 1 and the failure mechanism is not brittle (such as in rocks where the initiation of failure could substantially reduce the strength of the materials), then the critical seismic coefficient associated with the ground acceleration at which the factor of safety is one shall be assessed using large strain soil parameters consistent with the likely displacements due to earthquake shaking.

6.3.2 continued

- The displacement likely at the design damage control limit state and at the collapse avoidance limit state seismic response, shall be assessed using moderately conservative soil strengths consistent with the anticipated stress-strain behaviour and relevant strain levels and a Newmark sliding block displacement approach. Displacements may be assessed using the methods described by Ambraseys and Srbulov⁽⁵⁾, Jibson⁽⁶⁾, Bray and Travasarou⁽⁷⁾ or as outlined in *Earthquake geotechnical engineering practice*, module 3 – Identification, assessment and mitigation of liquefaction hazards⁽⁸⁾ using the relevant peak ground accelerations (see 6.2), and the distance to the dominant earthquake sources in the area. Where a Newmark sliding block method is applied, the 50th percentile displacement shall be derived for both the damage control limit state and collapse avoidance limit state events. At least three different commonly accepted methods for the assessment of the displacement shall be used and the range of predicted displacements (rather than a single value) should be used in the design process. In general, the upper bound values should be adopted unless a lesser value is otherwise justified and accepted by the road controlling authority.
- The serviceability limit state requirements of 6.1.2(a) shall be satisfied.

6.3.3 Earthquake induced liquefaction

Further to the requirements set out below, additional guidance on the assessment of liquefaction and cyclic softening may be obtained from *Earthquake geotechnical engineering practice*, module 3⁽⁸⁾.

a. Soils susceptible to liquefaction and cyclic softening

The liquefaction of saturated predominantly cohesionless soils (generally sand, silt and loose sandy gravels) and cyclic softening of clays and plastic silts during strong earthquake shaking shall be taken into consideration in the design of structures, including highway bridges and their approaches, soil structures and the stability assessment of natural slopes.

b. Site investigations

Site investigations (including field and laboratory testing) should be adequately scoped to provide sufficient information for the assessment of seismic behaviour of the soils including:

- assessment of liquefaction susceptibility of the site soils
- assessment of the soils' potential for cyclic softening
- analysis of triggering of liquefaction and cyclic softening (using the design earthquake loading specified in 6.2)
- evaluation of consequences of liquefaction and cyclic softening.

The following investigation procedures can be used for the assessment of liquefaction potential of soils and their susceptibility to lateral spreading:

- historical evidence of liquefaction
- geological assessment of the site to identify whether the site soils might be susceptible to liquefaction
- cone penetration test (CPT or CPTU where pore water pressure is measured)
- boreholes with associated standard penetration tests (SPT) and sampling
- shear wave velocity tests (such testing should be carried out in accordance with ASTM D4428/D4428M *Standard test methods for crosshole seismic testing*⁽⁹⁾ or ASTM D5777 *Standard guide for using the seismic refraction method for subsurface investigation*⁽¹⁰⁾)

6.3.3 continued

- in-situ and laboratory shear vane tests
- measurement of groundwater table using piezometers and assessment of seasonal fluctuation of groundwater table
- assessment of artesian aquifers' regime
- monotonic and cyclic triaxial tests
- monotonic and cyclic simple shear tests
- laboratory testing including grading and Atterberg limit tests
- topographical survey of the site including survey of river and stream banks, as well as river, stream and sea bed levels where the site is within 200m of a free face.

Within granular soil layers (including granular materials with fines) that may have potential for liquefaction, SPTs should be performed at 1m or 1.5m centres. Also, push tube samples should be taken within cohesive soil layers.

It should be noted that the results of the cyclic triaxial and cyclic simple shear tests are very sensitive to the quality of soil samples. Sampling techniques minimising disturbance of soil samples, eg as described by Taylor, Cubinovski and Haycock⁽¹¹⁾ or Hofmann and Robertson⁽¹²⁾ should be used.

Where liquefaction susceptible soils containing gravels are present, where static cone penetration tests and standard penetration test results would be influenced by gravel particles, the use of in-situ shear wave velocity tests should be considered.

Additional dynamic triaxial tests should be considered if the potential for liquefaction or cyclic softening is uncertain but is critical to the performance of a significant structure.

CPT testing shall be carried out in accordance with ASTM D5778 *Standard test method for electronic friction cone and piezocone penetration testing of soils*⁽¹³⁾.

SPT testing should be carried out generally in accordance with ASTM D1586 *Standard test method for standard penetration test (SPT) and split-barrel sampling of soils*⁽¹⁴⁾ and ASTM D6066 *Standard practice for determining the normalized penetration resistance of sands for evaluation of liquefaction potential*⁽¹⁵⁾. All SPT tests shall be carried out using a hammer with a measured energy efficiency ratio.

Except when gravel particles are present (as noted above), shear wave velocity testing can be employed only as a testing procedure additional to SPT and CPT tests.

The results of the site investigations are to be documented in a site investigation factual report.

c. Liquefaction and cyclic softening triggering assessment

Materials such as sands, non-plastic silts, gravels and their mixtures may be susceptible to liquefaction. Clays and plastic silts are not susceptible to liquefaction but can be prone to softening under cyclic load.

The analysis of whether the soil is likely to experience sand-like behaviour (liquefaction) or clay-like behaviour (cyclic softening) should be carried out and the effects of cyclic softening should be assessed in accordance with recommendations given in Boulanger and Idriss (2006⁽¹⁶⁾ and 2007⁽¹⁷⁾) and Bray and Sancio⁽¹⁸⁾.

To ensure that the assessment of liquefaction and cyclic softening of soils is carried out in a uniform and consistent manner the following procedures shall be followed:

- Ground motion parameters (unweighted earthquake PGAs and respective earthquake magnitudes) shall be derived as described in 6.2.2.

6.3.3 continued

- Triggering of liquefaction for materials with sand-like behaviour shall be carried out in accordance with the simplified procedure described in Boulanger and Idriss (2014⁽¹⁹⁾) unless specified otherwise in the principal's requirements or the requirements and minimum standards. The PGA required for the assessment of liquefaction triggering shall be derived as described in 6.2.2. The potential for liquefaction of the site at each of the limit states shall be assessed.

It should be noted that the data used for the development of the simplified procedure relates to depths of less than 15m. Extrapolation of the simplified procedure to greater depths should account for the increased uncertainties at depths greater than 15m.

Special care, expertise and additional calculations are required when the simplified liquefaction triggering procedure is employed for depths greater than 15 - 20m. For depths greater than 20m, an alternative to the simplified procedure is to perform a nonlinear, total or effective stress site response analysis utilising a computer code capable of modelling non-linear soil behaviour and, for effective stress analysis, pore water pressure generation and dissipation.

If effective stress site response analysis is used, the geotechnical designer shall provide evidence that their model has been appropriately validated and calibrated with field data, laboratory data and sensitivity analyses. Due to the specialised nature of this more sophisticated liquefaction assessment method, the road controlling authority's approval to the use of non-linear effective stress methods for liquefaction evaluation shall be obtained.

Most of the case studies used for the development of the simplified procedure for the assessment of liquefaction triggering based SPT and CPT data relate to sites formed by Holocene-age alluvial or fluvial sediment. Assessment of liquefaction potential of pumice soils based on CPT and SPT tests has been proven to be unreliable. Cyclic triaxial and cyclic simple shear tests on high quality undisturbed samples and shear wave velocity profiling should be considered for such materials; other methods of soil characterisation listed in 6.3.3(b) can also be used.

Each liquefaction or cyclic softening assessment procedure recommended in this *Bridge manual* shall only be used with the same analysis framework (and all its components) that was used to develop the procedure from the case history database.

In order to minimise discrepancies in assessments of liquefaction potential of soils for the tender design by different designers and enable a fair evaluation process, clear instructions and guidance shall be given in the principal's requirements or the requirements and minimum standards. All parameters adopted and to be applied in the liquefaction assessment shall be fully reported in the specimen design report covering the geotechnical design philosophy.

Where index values measured in the field (eg CPT cone resistance and sleeve friction) are used to calculate the fines correction factors, the fines content determined from the index values shall be checked against soil sample descriptions and laboratory test data, and where there is a discrepancy, the values from the laboratory test data should be adopted.

K_α factors applied to cyclic resistance ratios shall not be greater than 1.0 but factors less than one shall be used where in-situ stress conditions will reduce the soil's resistance to liquefaction. This factor is related to different modes of sloping ground deformation (as opposed to level ground condition), which affects pore pressure development and consequent liquefaction.

Changes to in-situ ground pressures from the construction of cuttings or embankments shall be considered in the assessment of liquefaction triggering.

6.3.3 continued

Where significant embankments are proposed on liquefaction susceptible ground, the potential for liquefaction with and without the overburden contribution of the embankment shall be assessed. The construction of significant embankments would result in increased overburden pressure on the foundation ground and may also induce some initial shear stresses in the soil. Such effects need to be considered in the assessment of liquefaction potential of the foundation ground.

Where embankments are to be constructed over potentially liquefiable soils, soil index values (eg CPT cone resistance, SPT blow count, shear wave velocity) measured prior to the construction of the embankment shall not be factored to account for densification unless the adopted factors are proven with field measurements for trial embankments or post-construction field measurements.

Fines correction factors, calculated using soil index values measured prior to the construction of the embankment, should not be adjusted by changes that may be made to the index values based on assessed level of possible or actual densification.

The residual shear strengths of liquefied soils for geotechnical analysis and design shall be estimated from empirical correlations to SPT or CPT data based on the recommendations of section 6.3.4 of *Earthquake geotechnical engineering practice*, module 3⁽⁸⁾. It should be noted that these correlations are approximate. As there are discrepancies in the residual shear strengths assessed from different correlations, designers shall evaluate how the use of different correlations would affect the residual shear strengths of liquefied soil and the expected seismic performance of structures, natural slopes as well as soil structures.

The assessment of liquefaction and cyclic softening, together with all the assumptions, methods, and analysis results shall be documented. Values and correlations adopted as the basis for the design shall be justified and include sensitivity analysis as described above. Values determined from sensitivity analyses for design shall be subject to acceptance of the road controlling authority.

d. Assessment of the effects of liquefaction and cyclic softening

The following effects of liquefaction and cyclic softening shall be taken into consideration in the development of design concepts and design of the project:

- Loss of or substantial reduction in the foundation bearing capacity.
Bearing failures can lead to large total and differential settlement, tilt and overturning of structures and soil structures. The possibility of punching failures through a surface crust shall be considered in the design. Liquefaction in the soil zone adjoining or near the zone of influence (the soil zone loaded by a structural foundation or soil structure) may also reduce foundation bearing capacity and therefore should also be considered in the design process.
- Reduction in soil strength and stiffness due to liquefaction and cyclic softening resulting in a reduction in the foundation's (especially pile foundation) lateral capacity and stiffness leading to modification of the flexibility of the structure and an increase in damping and the fundamental period of the structure.
- Loss or substantial reduction in pile foundation capacity for uplift or lateral loading.
- Subsidence of the ground.

Subsidence shall be assessed using the methods of Ishihara and Yoshimine⁽²⁰⁾ or Zhang, Robertson and Brachman(2002)⁽²¹⁾. Such subsidence is also referred to as liquefaction-induced free-field settlement or settlement due to re-consolidation of liquefied soils.

6.3.3 continued

- Soil-structure-interaction-induced settlement (associated with volumetric strains due to groundwater flow in response to transient gradients), large shear deformation of liquefied ground as well as structure rocking and ratcheting effects.

This settlement is additional to the free field settlement and can be quite substantial for structures founded on shallow foundations and non-piled soil structures on liquefiable sites. It is therefore important to assess this settlement for structural foundations and soil structures. While there are no well-established methods for the assessment of soil-structure-interaction-induced settlement associated with liquefaction, Bray and Dashti⁽²²⁾ and Murashev, Keepa and Tai⁽²³⁾ provide useful information.

- Large lateral movements from ground oscillation.

An empirical procedure proposed by Tokimatsu and Asaka⁽²⁴⁾ can be used for the assessment of cyclic displacements of liquefied ground.

- Large lateral movements as a result of lateral spreading and flow failure of natural ground towards free surfaces such as river banks and of approach embankment slopes.

Lateral spreading displacements can be assessed by either empirical or Newmark-type methods described by Youd, Hansen and Bratlett⁽²⁵⁾, Tokimatsu and Asaka⁽²⁴⁾, Zhang, Robertson and Brachman (2004)⁽²⁶⁾, Jibson⁽⁶⁾ and Olson and Johnson⁽²⁷⁾. There is a substantial uncertainty associated with the assessment of lateral spreading displacements. For both the damage control limit state design earthquake event and the collapse avoidance limit state event, 50th percentile displacements shall be derived and the upper bound result from not less than three of the methods shall be used as the basis for design unless use of a lower value is otherwise justified and accepted in writing by the road controlling authority.

- Natural or fill slope instability due to strength reduction in liquefied soil layers or lenses (this slope instability is not necessarily associated with lateral flow or lateral spreading).
- Negative skin friction or down-drag on piles and buried structures or their elements due to subsidence associated with liquefaction, and the downward movement of liquefiable soil and any overlying or interbedded liquefaction resistant layers.
- Uplift and flotation of buried structures (eg culverts and tunnels) and soil structures (eg geofoam) or structural members such as piles and anchors.
- Possible ground loss underneath foundations or foundation elements due to ejecta. Ishihara⁽²⁸⁾ developed correlations between surface manifestation of liquefaction (such as surface rupture and sand boils), thicknesses of the liquefied layer and the overlying non-liquefied crust. Ishihara's correlations can be used to assess the risk of ground loss associated with ejecta.

6.3.4 Mitigation of liquefaction and site instability hazards

a. General

The design shall mitigate the risks associated with potential damage to the highway and associated structures, including soil structures, from liquefaction, cyclic softening or site instability, through ground improvement or provision of sufficient strength or ductility in the structures to resist liquefaction and site instability effects. Such mitigation shall ensure that the performance requirements of 5.1.2 for structures at the serviceability limit state, damage control limit state and collapse avoidance limit state and 6.1.2(b) for soil structures at the serviceability limit state and 6.1.2(c) for both structures and soil structures at the damage control limit state are achieved, unless agreed with the road controlling authority to be impractical or uneconomic.

6.3.4 continued

b. Liquefaction mitigation by ground improvement

Measures to mitigate liquefaction hazard by ground improvement, such as using densification by dynamic compaction or vibroflotation, deep mixing, drainage, or combined densification and drainage using vibro-replacement or stone columns, shall be considered to reduce the risk to the highway from liquefaction of the soils. Where the ground is densified, testing shall be undertaken following construction to confirm that the required level of ground improvement has been achieved. Consideration should be given to possible effects of pore water migration from untreated soil zones to treated soil zones and ground motion amplification. Pore water migration may occur during and after shaking, particularly when the improved zone consists of densified soil. Ground motions tend to be amplified by treated zones, particularly those extending completely through liquefiable deposits, resulting in higher supported structure accelerations and inertial forces. Where improved ground extends to stronger soil or bedrock at depth, the site subsoil class may need to be adjusted.

c. Foundations in liquefiable soils

Shallow foundations shall not be founded in liquefiable layers, or within a zone above liquefied layers equivalent to twice the width of the foundation, or where liquefaction will prevent the performance requirements for the foundation being satisfied. Additional reinforcement of the foundation subgrade shall be incorporated to minimise differential subsidence effects on the foundations.

Foundations below liquefiable layers shall be located to ensure that under liquefaction they continue to achieve acceptable performance and that the bearing capacity is not diminished or settlements increased to unacceptable levels. Piles shall be founded a minimum of three pile diameters below the base of soil layers prone to liquefaction. The reduction in deep foundation, including piles, pile lateral capacity, bearing or uplift capacity (such as due to reduction in pile shaft and foundation friction) shall be taken into consideration in the design.

d. Isolation of the structure from ground displacement

Where separation of the structure from the ground (eg by the sleeving of piers or piles) is adopted to isolate the structure from the effects of permanent ground displacement the degree of separation provided shall be sufficient to protect the structure from the more severe of:

- the cumulative displacement effects of at least two successive damage control limit state design earthquake events, to be taken as 200% of displacement arising from one DCLS design intensity earthquake; and
- the displacement effects due to one CALS event.

6.3.5 Design scenarios to be considered

When evaluating the effects of liquefaction, cyclic softening and lateral spreading on the performance of a structure (eg pile foundations) using equivalent or pseudo static analysis, it is necessary to conduct separate analyses for different stages of the response. Scenarios to be considered are:

- i. Peak structural and ground response preceding liquefaction developing, in which inertial loads that would occur in the absence of liquefaction are considered. (Embankment and slope movements may occur in this scenario and should be taken into account.)

6.3.5 continued

- ii. Ground response with liquefaction or cyclic softening developing, and with the structural response modified for period shift due to softening of the foundation stiffness. This will involve estimating the potential and consequences of liquefaction, and considering simultaneous kinematic loads (due to cyclic ground displacements) and structural inertial loads while accounting for stiffness and strength degradation of the soils due to excess pore water pressures. For equivalent or pseudo static analysis, not less than 80% of the design structural inertial loading plus 100% of the cyclic kinematic loads shall be assumed to act concurrently with full degradation of the soil strength and stiffness due to liquefaction*. (Embankment and slope movements may occur in this scenario and should be taken into account.)
- iii. Lateral soil spreading due to liquefaction having developed. This analysis requires estimating the potential for liquefaction and consequences of lateral spreading including substantial stiffness and strength degradation and the kinematic loads due to large spreading displacements. Inertial loads of the structure are in general of secondary importance in the spreading phase and may be ignored except in the following case. When, for DCLS or CALS events at the site, the percentage of the hazard contributing to the peak ground acceleration by a magnitude 7.5 or greater earthquake is more than 20%, the lateral spreading/flow failure forces on foundations shall be combined with the plastic hinge force or 25% of the structure inertial forces, whichever is less.

The design earthquake response spectrum for scenario (i) shall also be applied for scenarios (ii) and (iii). Scenario (ii) shall be considered if triggering of liquefaction is predicted, and scenario (iii) if lateral spreading is anticipated.

If liquefaction does not occur, or only occurs in small localised lenses that have no effect on ground displacements (kinematic loads), stiffness and strength degradation in the equivalent static analysis, scenarios (ii) and (iii) will not arise to any significant extent and do not need to be considered.

Where liquefaction and/or soil lateral spreading may occur or become more severe in earthquake events greater than the damage control limit state design intensity event but less than or equal to the collapse avoidance limit state intensity event, such that the soil loads on the structure dramatically increase and/or the nature of soil restraint to the structure is significantly reduced compared to that applying during an damage control limit state design intensity event, consideration shall be given to implications of these changes in the actions acting on the structure or restraint conditions applying to the structure for the avoidance of collapse of the structure.

Existing methods used for the assessment of liquefaction triggering and the consequences of liquefaction are not very accurate. Materials that have a factor of safety against liquefaction of less than 1.1 should be considered to be liquefiable in the design analysis unless otherwise agreed with the road controlling authority.

Even if full liquefaction is not predicted to occur, partial pore pressure build-up can result in deterioration of strength and stiffness of soils. The potential pore pressure build-up shall be assessed for damage control limit state and collapse avoidance limit state events and, where factor of safety against liquefaction is higher than 1.1 but less than 1.4, reduced stiffness and strength shall be used for the assessment of slope stability and foundation bearing capacity affecting the support of structures and soil structures.

* The peak cyclic ground displacement and superstructure inertial force are transient conditions occurring momentarily during the course of strong shaking. They may or may not occur at the same instant. For pseudo-static analysis of seismic problems, the load combination producing the critical (peak) pile response in liquefying soils cannot be predicted with any high degree of certainty. Therefore there is no commonly accepted strategy on how to combine these loads in pseudo-static analysis. Tamura and Tokimatsu⁽²⁹⁾ suggested that the phasing of the kinematic and inertial demands varies, and depends primarily on the natural frequency of the superstructure and soil deposit. Ashford, Boulanger and Brandenburg⁽³⁰⁾ suggested a simplified expression allowing for different combinations of kinematic and inertial loads on the pile while accounting for the frequency content characteristics of the ground motion. In the absence of commonly accepted strategy, the proposed 80% of the design structural inertial loading acting concurrently with kinematic load is considered to be an acceptable design approach.

6.3.5 continued

The magnitude of the pore pressure generation and associated degradation of soil strength and stiffness are a function of the factor of safety against liquefaction and soil type. The magnitude of the pore pressure build up can be assessed as recommended by Marcuson, Hynes and Franklin⁽³¹⁾. In soil layers that experience pore pressure generation, the shear strength of the soil should be reduced by using a reduced effective stress due to pore pressure build up. More detailed recommendations on the reduction of soil strength and stiffness due to pore pressure build up are given by Ardoino et al⁽³²⁾.

6.3.6 Optimisation of ground improvement

Ground improvement is costly. Where liquefaction or cyclic softening problems are identified as potentially causing lateral spreads that may damage the structure (including soil structures), the following options should be considered:

- For new structures: relocate the structure to another less vulnerable site. This option should be considered at the concept design stage. If the risk of liquefaction or cyclic mobility is identified for a proposed route, alternative routes with better ground conditions at structure sites should be considered.
- For new and existing structures on liquefiable sites: soil-foundation structure interaction analysis should be undertaken to determine whether the deformation and load capacity of the foundation/structure system is adequate to accommodate the ground deformation demands and meet the performance criteria specified by 5.1.2 as well as the serviceability criteria specified by 6.1.2(b) (assuming no ground improvement); and where the foundation/structure system is found to be inadequate the most cost-efficient of the following options should be used:
 - foundation/structure system should be strengthened to accommodate the predicted liquefaction and related ground deformation demands
 - ground improvement should be undertaken to reduce liquefaction potential of soils and minimise ground displacement to acceptable levels
 - possible combination of the above two options.

This analysis will require close interaction between the structural and the geotechnical designers and shall be undertaken in accordance with NZTA research report 553⁽⁴⁾ guidelines, *Analysis of piled bridges at sites prone to liquefaction and lateral spreading in New Zealand*⁽³³⁾, *Earthquake geotechnical engineering practice*, module 5 - Ground improvement of soils prone to liquefaction⁽³⁴⁾ or similar methodology approved by the road controlling authority.

Where ground improvement is specified by the designer, the road controlling authority may require the designer to submit evidence of ground improvement optimisation analysis in accordance with this methodology. For projects where the cost of ground improvement is more than \$1.1 million (price at June 2018^{*}), consideration should be given to the use of inelastic time history finite element analysis of soil-foundation structure interaction to optimise the extent of ground improvement.

For design and construct type projects on sites prone to liquefaction, cyclic mobility or lateral spreading, assessment of liquefaction and optimisation of ground improvement should be carried out at the stage of specimen design and clear requirements should be included in the principal's requirements for the project.

^{*} Values shall be adjusted to current value. For the relevant cost adjustment factor refer to the NZTA's *Procurement manual*, Procurement manual tools, Latest values for 1991 infrastructure cost indexes, NZ Transport Agency Construction index⁽²⁾

6.4 Design of earthworks

6.4.1 Design of embankments

a. Philosophy

The design of embankments shall be based on adequate site investigations and shall ensure acceptable performance of the embankment under gravity, live and earthquake loads, under flood and post-flood drawdown conditions, under conditions of changing groundwater levels and where water mains are present under the eventuality of them rupturing. Embankments considered to be dams, as defined in the Building Act 2004, shall satisfy all necessary requirements for the applicable dam definition. Appropriate measures shall be specified to ensure that post-construction settlements will be within acceptable limits compatible with the performance expectations for the road. Such limits shall be agreed with the road controlling authority.

b. Static behaviour

Under static conditions (including appropriate live load surcharge) completed embankments shall have a minimum design long term factor of safety against all modes of failure of 1.5 based on moderately conservative effective stress soil strengths under moderately conservative design operating piezometric conditions. This shall apply unless specific justification for a lower value has been accepted in writing by the road controlling authority.

A suitable monitoring programme shall be implemented by the designer to check embankment performance during and after construction. The designer shall specify acceptable limits for monitoring measurements.

During construction, embankments shall possess a minimum design static short term factor of safety against all modes of failure of 1.2 based on moderately conservative effective stress soil strengths or undrained shear strength parameters, under moderately conservative design operating piezometric conditions.

Where preloading, surcharging, staged loading, vertical drains or other techniques are required to permit construction of embankments or to accelerate settlement, a suitable monitoring programme shall be specified and the results shall be reviewed by the designer.

Factors of safety shall be calculated using loads and combinations for the serviceability limit state as specified in table 3.1.

c. Behaviour in seismic and flood events

Assessments shall be made of the potential for embankment materials and underlying foundation materials to lose strength during or after flooding or earthquake. The presence of liquefiable, collapsible, sensitive or erodible materials shall be determined by appropriate site investigations and testing. Where such materials are present, assessments shall be made of the risk presented by them and the feasibility and cost of eliminating or reducing risks and/or damage.

Unless it is accepted by the road controlling authority to be impractical or not economically viable to significantly reduce the risk of embankment failure due to earthquake or flooding, the following design criteria shall apply:

6.4.1 continued

i. For seismic events

For the assessment of the stability of embankments using pseudo-static seismic analysis the peak ground acceleration to be applied shall be derived in accordance with 6.2 for the annual probability of exceedance associated with the importance of the slope as defined in 2.1.3. In applying the pseudo-static analysis, the PGA shall not be factored down by a structural performance factor or any other factor.

Where embankments are designed on the basis of permitting displacement under earthquake response, the requirements of 6.6.9 shall also be satisfied.

For the following situations the minimum factors of safety and supporting requirements shall be satisfied under the damage control limit state earthquake event:

- Embankment stability not affecting bridges

In situations where liquefaction either does not occur or prior to liquefaction occurring:

Factor of safety ≥ 1.0 , or

Factor of safety < 1.0 and permanent displacements less than the limits given in table 6.1.

- Embankment stability and liquefaction not affecting bridges

Where liquefaction is anticipated under the design seismic event, the design criteria for embankment stability not affecting bridges are to be met with post-liquefaction soil strengths and the embankment subjected to the design damage control limit state PGA.

- Embankment stability affecting bridges

In situations where liquefaction either does not occur or prior to liquefaction occurring:

Factor of safety ≥ 1.0 ; and

The seismic performance requirements for structures as specified in this manual are met.

Where a factor of safety of 1.0 cannot be achieved, the bridge shall be either isolated from the ground movement or designed to withstand the loads and effects imposed on it by the ground movement so that the seismic performance of this manual are met.

- Embankment stability and liquefaction affecting bridges

Where liquefaction is anticipated under the design seismic event, the design criteria for embankment stability affecting bridges are to be met for either the factor of safety ≥ 1.0 or the factor of safety < 1.0 , whichever is appropriate, with post-liquefaction soil strengths and the embankment subjected to the design damage control limit state PGA.

All displacements referred to in this item (i) should be assessed as described in 6.3.5.

ii. For flood events

Where embankments may act as water retaining structures during flooding, the embankment shall remain stable under the lateral pressure and the ability of the embankment to sustain the effects of seepage and drawdown shall be examined. In such cases the embankment shall have a minimum factor of safety against failure of 1.25 unless there is potential for significant downstream damage or loss of life, in which case a minimum factor of safety of 1.5 shall apply. The *Dam safety guidelines*⁽³⁵⁾ provides guidance on embankments that may act as water retaining structures.

6.4.1 continued

Where lightweight embankments are constructed utilising geofabric materials (polystyrene or similar) a factor of safety of not less than 1.1 against flotation shall be provided under the ultimate limit state design flood event.

Factors of safety shall be calculated using loads and combinations for serviceability limit state as specified in table 3.1.

Adequate protection from erosion during flooding or from adjacent waterways shall be incorporated into the design of embankments.

Where it is not practical or economically justifiable to significantly reduce the risk of embankment failure due to earthquake or flooding, and the effect of such failure on the performance of the road network, considering the required levels of service and lifeline requirements, is acceptable to the road controlling authority, then the design may allow for failure to occur in such large events (unless there are significant potential downstream effects on property, public/private infrastructure or the effects are potentially life threatening). In such cases the manner and extent of such failure shall be assessed and, where bridges are affected, the bridge structure and foundations shall be designed to accommodate the embankment failure without damage to the structure.

Where it is proposed to accept failure of the embankment under the design earthquake, or under flood conditions, in order to adopt a factor of safety of less than specified above, justification for doing so shall be set out in a design statement for the road controlling authority's consideration and acceptance in writing, before the proposal is adopted.

d. Loadings on associated bridge structures

Earth pressure loadings, lateral loads due to ground deformation or displacement and negative friction effects on foundations that arise from the presence of the embankment shall be taken into account. Appropriate load factors shall be applied in accordance with 3.5.

6.4.2 Design of cuttings

Cuttings shall be designed in accordance with recognised current highway design practice with provision of benches, and appropriate measures to mitigate the effects of rock fall and minor slope failures. As appropriate, design shall generally comply with 6.4.1 and the factors of safety for embankments given in 6.4.1 shall also be applied to the global stability of cuttings. Slope geometry shall be designed to ensure that any slope failure material will not be deposited against or over any bridge, gantry or soil structure. Where this is not practicable, provision shall be made in the design of these structures for additional dead load or earth pressure to represent the effect of slope failure material.

Where it is proposed to accept a significant risk of instability, justification for doing so shall be set out in the design statement for the road controlling authority's consideration and acceptance in writing before the proposal is adopted.

Where cutting slopes are designed on the basis of permitting displacement under earthquake response, the requirements of 6.6.9 shall also be satisfied.

6.4.3 Natural ground instability

Where any structure, soil structure or the highway can be affected by instability or creep of natural ground, measures shall be taken to isolate the structure or highway, remedy the instability, or design the structure or highway to accommodate displacements and loads arising from the natural ground. As appropriate, design shall generally comply with 6.4.1, and the factors of safety given in 6.4.1 shall be used.

Where slopes are designed on the basis of permitting displacement under earthquake response, the requirements of 6.6.9 shall also be satisfied.

6.5 Foundations

6.5.1 Loads on foundations

Foundations to structures and soil structures shall be designed for bearing capacity and stability to resist combined horizontal and vertical loadings with acceptable displacements and settlement. Consideration shall be given to the behaviour of the founding soils under static and dynamic loading and during construction.

Foundations shall be designed to resist loads that may arise from settlement or ground subsidence and associated negative friction (down-drag). Lateral loads associated with slope movements, lateral spreading and liquefaction shall be considered, although wherever practicable the designer shall isolate the structure and foundations from such forces.

The effects of live load may normally be ignored in the evaluation of foundation settlement, except in special cases where the live load is sustained over long periods of time. The repetitive nature of live load shall be taken into consideration, where it has the potential to affect foundation performance.

6.5.2 Design standards for foundations

- a. Foundation design shall be based on appropriate sound design methods and shall satisfy the *Building code*⁽³⁶⁾.
- b. The following standards and codes of practice provide guidance on the design of foundations:
 - *New Zealand building code verification method B1/VM4*⁽³⁷⁾.
 - BS EN 1997-1 *Eurocode 7 Geotechnical design part 1 General rules*⁽³⁸⁾, plus BS EN 1998-5 *Eurocode 8 Design of structures for earthquake resistance part 5 Foundations, retaining structures and geotechnical aspects*⁽³⁹⁾.
 - *S6 Canadian highway bridge design code*⁽⁴⁰⁾.
 - *AASHTO LRFD Bridge design specifications*⁽⁴¹⁾.
 - *AS 2159 Piling - Design and installation*⁽⁴²⁾.
- c. The NZTA's *Bridge manual* shall take precedence where there is a conflict.

6.5.3 Strength reduction factors for foundation design

Strength reduction factors shall be applied in the strength design of foundations for their bearing capacity and resistance to sliding. The strength reduction factors for sliding of shallow foundations shall be derived from table 1 of B1/VM4⁽³⁷⁾. The strength reduction factors for bearing capacity of shallow and pile foundations shall be derived using the risk based methodology set out in AS 2159⁽⁴²⁾ section 4.3, and shall be presented in the structure design statement for acceptance by the road controlling authority.

The strength reduction factors adopted for bearing capacity of shallow foundations shall be taken as $\phi_g = \phi_{gb}$, where ϕ_{gb} is defined in AS 2159⁽⁴²⁾ and shall not exceed a maximum value of $\phi_g = 0.6$ for all load combinations, excluding earthquake overstrength where higher strength reduction factors, up to $\phi_g = 0.75$, may be adopted.

Strength reduction factors adopted for bearing capacity of both shallow and piled foundations shall not exceed a maximum value of $\phi_g = 0.75$, regardless of whether static, dynamic, or gravitational loading, or seismic loading induced by overstrength capacities developing are being considered.

6.5.4 Capacity design of foundations

The principles of capacity design are outlined in section 5.

The foundations should not compromise the seismic performance of the superstructure (above foundation level structure). Increasing flexibility in the foundations generally has the effect of increasing the curvature ductility demand imposed on plastic hinges or the element ductility demand on elements such as mechanical energy dissipating devices in the superstructure and exceeding the capacity of these elements needs to be avoided.

The foundations must be capable of transmitting the largest feasible actions to the supporting soil, and the soils must be capable of resisting the pressures applied by the foundations, otherwise the intended seismic response of the superstructure cannot eventuate. For structures designed using capacity design principles, the capacity of the footings, piles or caissons shall be such that deformations developed in the supporting soil under actions corresponding to the over-strength of the superstructure are limited in terms of their magnitude, so that the intended seismic response of the superstructure can eventuate.

In general, foundation systems shall be designed to preclude foundation failure, or uplift of an entire foundation element, at loadings corresponding to yielding of the earthquake energy dissipating elements, taking concurrency effects into account where applicable. Where it is intended to allow the rocking of foundations, inelastic time history analyses or a simplified analysis based on equilibrium consideration, as described in appendix A of the *AASHTO Guide specifications for LRFD seismic bridge design*⁽⁴³⁾ shall be performed to study the structure's behaviour as required by 5.6.12 and bearing areas within the foundation shall be so proportioned as to protect the soil against excessive plastic deformations that would be difficult to predict and which may result in premature misalignment of the otherwise undamaged superstructure.

Since there is greater uncertainty in the strength and stiffness properties of the ground, and their contribution to either increased loads or reduced resistance, as compared to other structural materials and depending on the case, it is not appropriate to use a single factored down strength for the soils and rocks. Upper and lower bound strength and stiffness properties of the soils shall be applied in order to assess the most adverse performance likely of the structure, which is to be adopted as the basis for its capacity design.

6.5.5 Foundation capacity determination

The load capacity of foundations shall be assessed using geotechnical parameters from geotechnical investigations and tests, and soil/rock mechanics theory or semi-empirical geotechnical methods. The ultimate capacity of foundations shall be assessed in accordance with the recommendations of the *New Zealand building code verification method B1/VM4*⁽³⁷⁾. The capacity shall be confirmed during construction as specified in 6.5.6.

6.5.6 Confirmation of foundation conditions during construction

The designer shall clearly state on the drawings and in the specifications, the foundation conditions assumed in the design, or ensure that the designer is consulted during construction to ensure that the design requirements are being met.

The foundation conditions shall always be verified during construction, against the ground conditions assumed in the design, as site investigations cannot fully define the actual ground conditions at each foundation. The designer shall specify measures to be used to verify the ground conditions.

Appropriate measures to confirm foundation conditions may comprise one or more of the following, depending on the particular situation:

6.5.6 continued

- Inspection, logging and possibly testing of the ground by a geotechnical engineer or engineering geologist.
- Plate bearing tests.
- Static pile load tests.
- Pilot hole drilling and testing.
- Down-hole inspection of pile shaft, particularly in bedrock.
- Dynamic pile load tests.
- Pile capacity assessment based on pile driving analysis.

The Hiley formula has traditionally been used to confirm the pile capacities in cohesionless soils, by relating the pile driving energy and the pile set (displacement per hammer blow) to pile capacities. The limitations of this method are now recognised. A more sophisticated method involves analysis of the pile response to hammer driving, using a pile driving analyser. Usually the pile response data should be further interpreted using a signal matching program such as CAPWAP or similar. Such methods still have their limitations and these should be recognised by the designer.

- Pile integrity tests to confirm the structural integrity of the pile, the relative shape of the pile shaft or the continuity of the pile.

Pile integrity tests shall be specified where the piles are not permanently cased and where there is a risk of collapse of the ground during construction of bored piles, particularly below the water table, or where there is significant potential for damage to the pile shaft during pile driving.

The type of pile integrity testing to be used shall be specified by the designer.

6.6 Earth retaining systems

6.6.1 General

a. Scope

This section covers:

- i. Non-integral bridge abutments (as compared with integral or semi-integral abutments defined in 4.8) and independent retaining walls associated with bridges. An abutment is defined as a substructure system that incorporates earth retaining members, and also supports part of the superstructure. Wing walls are part of the abutment if they are integral with it. Independent walls that are associated with bridges are defined as those walls that are not integral with the bridge abutment and which retain ground that provides support to bridge substructure elements and also walls that support approach fills at the bridge.
- ii. Retaining walls not associated with bridges.
- iii. Earth retaining structures (including mechanically stabilised walls and slopes).
- iv. Slopes designed on the basis of undergoing displacement.

b. Loads, displacements and settlement

Earth retaining systems shall be designed to ensure overall stability, internal stability and bearing capacity under appropriate combinations of horizontal and vertical loads, with acceptable displacements and settlement.

6.6.1 continued

The designer shall derive the design loads on the structure in accordance with 6.2, taking into consideration the flexibility and likely deformation of the structure, and the allowable displacement or deformation of the system. Careful consideration shall be given to the interaction between the structure, the ground and foundations, under static, dynamic, earthquake and construction conditions. The deformation and displacement of the structure shall be compatible with the performance requirements for the structure and its interaction with adjacent or supported structures and facilities. Earthquake displacement criteria are specified in 6.6.9.

The design of all types of retaining wall shall consider the effects of total and differential settlement and designs shall accommodate all resulting effects. In particular, movement gaps and other measures may be necessary to prevent structural damage or to prevent unsightly cracking or spalling.

c. Side protection

i. Road safety barriers adjacent to roads

Barriers for traffic and vulnerable road users shall be provided for retaining walls supporting road carriageways, footpaths, cyclepaths and equestrian paths as required in appendix B.

Where road safety barriers are positioned close to tops of earth retaining structures and can affect the performance of or apply additional load to the earth retaining structure, the earth retaining structure and its facing shall be designed to withstand the forces imposed on it by the design barrier loading (see B6.3).

Road safety barriers shall not be fixed to the face of reinforced soil walls.

ii. Safety fences and barriers remote from roads

Safety from falling protection shall be provided at the top of retaining structures (and slopes) that are within the highway reserve but remote from the road that are adjacent to other public areas where people could fall 1.0m or more. The form of the protection provided shall meet the requirements of the *New Zealand building code* acceptable solution F4/AS1⁽⁴⁴⁾.

Consideration shall also be given, through a risk assessment approach, to the need for safety from falling protection at the top of retaining structures (and slopes) within the highway reserve but remote from the road, where there may be the occasional presence of people (see B2.9) and a serious falling hazard exists within 1.5m of the edge of the path or working area. This shall take into account the frequency and nature of inspection and maintenance activities, and also the likelihood of public access to the area. For these purposes a serious falling hazard may be considered as defined in clause 5.19.1(c) of the *Highway structures design guide*⁽⁴⁵⁾.

Where a barrier is considered to be necessary, as a minimum, safety from falling barriers 1000mm high, complying with the requirements of clause 1.2.2 of *New Zealand building code* acceptable solution F4/AS1⁽⁴⁴⁾ (excepting the reduced height) shall be provided. Barriers 1100mm high shall be provided where children less than six years of age are expected to frequent a public area.

In both the above situations, the structural design of the barriers shall be in accordance with section 5.19.2 of the *Highway structures design guide*⁽⁴⁵⁾.

6.6.2 Design standards for earth retaining systems

The following standards and codes of practice provide guidance on the design of retaining structures:

- Road Research Unit bulletin 84, volume 2⁽³⁾.
- BS EN 1997-1 *Eurocode 7 Geotechnical design part 1 General rules*⁽³⁸⁾, plus BS EN 1998-5 *Eurocode 8 Design of structures for earthquake resistance part 5 Foundations, retaining structures and geotechnical aspects*⁽³⁹⁾.
- AS 4678 *Earth-retaining structures*⁽⁴⁶⁾.
- S6 *Canadian highway bridge design code*⁽⁴⁰⁾.
- AASHTO *LRFD Bridge design specifications*⁽⁴¹⁾.
- FHWA NHI-99-025 *Earth retaining structures*⁽⁴⁷⁾.
- CIRIA C580 *Embedded retaining walls – guidance for economic design*⁽⁴⁸⁾.

Road Research Unit bulletin 84⁽³⁾ shall be used in preference to the other documents, particularly for earthquake resistant design.

The NZTA's *Bridge manual* shall take precedence over all other documents.

6.6.3 Strength reduction factors and factors of safety for earth retaining systems

Free-standing retaining structures shall be designed using loads and combinations as specified in tables 3.1 and 3.2 and section 6.2. The strength reduction factor for sliding shall be derived from table 1 of B1/VM4⁽³⁷⁾. The strength reduction factors for bearing capacity of retaining structure foundations shall be derived using the risk based methodology set out in AS 2159⁽⁴²⁾ section 4.3, and shall be presented in the structure design statement for acceptance by the road controlling authority.

The strength reduction factors adopted for bearing capacity of retaining structure foundations shall be taken as $\phi_g = \phi_{gb}$, where ϕ_{gb} is defined in AS 2159⁽⁴²⁾ and shall not exceed a maximum value of $\phi_g = 0.6$ for all load combinations, excluding earthquake overstrength where higher strength reduction factors, up to $\phi_g = 0.75$, may be adopted.

Strength reduction factors adopted for bearing capacity shall not exceed a maximum value of $\phi_g = 0.75$, regardless of whether static, dynamic, or gravitational loading, or seismic loading induced by overstrength capacities developing are being considered.

Potential deep-seated failure surfaces behind a retaining structure and extending below the toe of the retaining structure shall be analysed. Both circular arc and sliding wedge methods shall be used.

A number of slope stability analysis computer programs are available most of which use unfactored loads and soil parameters. Therefore, unfactored loads and soil parameters shall be used for the deep-seated failure analysis.

The minimum acceptable factors of safety against deep-seated failure shall be as follows:

- for static conditions: factor of safety = 1.5
- for seismic conditions: factor of safety = 1.25

If a retaining structure is designed for permanent displacement under earthquake loads, the above recommendations on the reduction factors and factors of safety will not apply. Requirements for structures designed for permanent displacement are specified in 6.6.9.

6.6.4 Common highway earth retaining systems

Different common earth retaining systems used for highway construction are listed in table 6.4.

MSE walls comprise reinforcement elements in the ground to stabilise the soil against failure. A wall face (eg reinforced concrete panels or blocks) connected to the reinforcement is generally provided.

6.6.4 continued

MSE walls can be divided into two types:

- Soil-nailed walls, where the reinforcement is inserted into the ground, with top-down construction as excavation for the wall face proceeds.
- Reinforced soil walls, where the reinforcement is incorporated within fill as the fill is placed and compacted, to build the wall using bottom-up construction.

Specific requirements for different earth retaining systems in common use are specified in the following sections.

Table 6.4: Earth retaining system categories

Earth retaining category	Earth retaining systems
Gravity and reinforced concrete cantilever walls	<ul style="list-style-type: none"> • gravity walls (concrete, gabion, crib) • reinforced concrete cantilever walls
Anchored walls	<ul style="list-style-type: none"> • anchored gravity walls • anchored cantilever walls • anchored soldier pile walls
Mechanically stabilised earth (MSE) walls	<ul style="list-style-type: none"> • soil-nailed walls • reinforced soil walls <ul style="list-style-type: none"> – inextensible reinforcement – extensible reinforcement

6.6.5 Gravity and reinforced concrete cantilever walls

Gravity and reinforced concrete cantilever walls are relatively rigid and are less tolerant of settlements. Therefore they shall be founded on an appropriate competent stratum to minimise settlements.

These walls may be designed to undergo limited sliding displacement under strong earthquake shaking as specified in 6.6.9.

6.6.6 Anchored walls

a. Walls that are restrained using anchors are designed to transfer some of the loads on walls to the ground outside the zone of influence of the wall.

Anchors transfer the loads into the ground through:

- deadman structures
- grouting anchors into drilled holes
- mechanical systems.

b. Anchors shall only be allowed to intrude into property outside the road reserve, if subsurface rights for the design life of the structure are obtained to prevent disturbance of the reinforced soil block by future subsurface (eg foundation, drainage) construction activities.

c. Anchored walls are generally rigid systems, and shall be designed to resist the full ground, groundwater and earthquakes forces on the walls. They shall not be designed to allow outward displacement by sliding in earthquakes or other conditions. An exception may be when the wall is anchored to a deadman that is designed to undergo limited displacement under strong earthquake shaking.

d. Ground anchors shall generally be designed and installed in accordance with established design standards such as BS 8081 *Code of practice for grouted anchors*⁽⁴⁹⁾, BS EN 1537 *Execution of special geotechnical work – ground anchors*⁽⁵⁰⁾ and FHWA-IF-99-015 *Ground anchors and anchored systems*⁽⁵¹⁾, except as provided in this document.

6.6.6 continued

- e. The anchor system shall be designed to ensure a ductile failure of the wall, under earthquake overloads as discussed in 6.6.9.
- f. The anchor system shall be corrosion protected to ensure its durability over the design working life of the structure.

Two classes of protection are provided for general use for anchors, as defined in table 6.5.

The class of corrosion protection shall be chosen based on the decision tree shown in figure 6.5.

In figure 6.5, a 'serious' consequence of failure shall arise when failure of the anchor and wall could:

- affect nearby buildings or other structures
- lead to closure of one or more lanes of the road causing major traffic disruption
- lead to disruption to a road that has a lifeline function
- lead to destabilisation of a landslide or slope that has experienced past instability.

In figure 6.5 'aggressive' shall be defined as where:

- the maximum pitting corrosion rate of unprotected steel is greater than 0.1mm/year or,
- soil resistivity is less than 2000ohm-cm or,
- pH of either the groundwater or soil is less than 5.0 or,
- total SO₃ in the soil is greater than 1% or,
- sulphates in groundwater is above 2500ppm, or
- chlorides in the groundwater are above 2000ppm.

- g. Pull-out tests shall be specified to be carried out on trial anchors to be installed prior to the final wall anchors being constructed. The pull-out tests shall be used to confirm the design grout-ground bond strengths. The number of tests shall be chosen and specified by the designer based on the variability of the ground conditions and the number of anchors required.
- h. On-site suitability tests shall be carried out on a selected number of initially installed special anchors or production anchors in accordance with BS EN 1537⁽⁵⁰⁾ to confirm the performance of the anchors and their suitability to ensure performance of the wall. A small number of representative full-scale anchors shall be installed and tested to confirm the suitability and performance of the anchors, prior to installation of the remainder of the anchors.

Table 6.5: Class of corrosion protection for anchors and soil nails

Class of protection	Corrosion protection standard
Class I	Double corrosion protection by encapsulation of the tendon or bar pre-grouted under factory conditions inside a corrugated plastic sheath to minimise crack widths in the pre-grouted grout as defined in BS 8081 ⁽⁴⁹⁾ . The whole assembly is grouted into the anchor hole.
Class II	Single corrosion protection using a galvanized (to AS/NZS 4680 ⁽⁵²⁾) or fusion bonded epoxy-coated (to ASTM A934/A934M ⁽⁵³⁾ or ASTM D3963/D3963M ⁽⁵⁴⁾) bar grouted into the anchor hole.

Note :

A higher class of protection, such as using multiple sheaths, may be chosen, depending on the aggressiveness of the environment, the consequences of anchor failure and the importance of the structure.

6.6.6 continued

- i. On-site acceptance tests shall be carried out on all anchors installed in accordance with BS EN 1537⁽⁵⁰⁾.
- j. If there is any reason for concern about the long-term performance of anchors supporting structures, and/or their ability to achieve the required design working life, the designer shall provide for future inspection, re-testing and replacement.
- k. The designer shall consider the long term maintenance of anchors and all elements forming part thereof. Where individual components (eg within the head assembly) have a working life less than the design working life, the designer shall detail replacement methodology in the inspection and maintenance requirements section of the structure design statements or soil structures report and within safety in design documentation. The long term monitoring and instrumentation should be carried out in accordance with FHWA-RD-97-130 *Design manual for permanent ground anchor walls*⁽⁵⁵⁾.

Figure 6.5: Guide to selection of corrosion protection for ground anchors

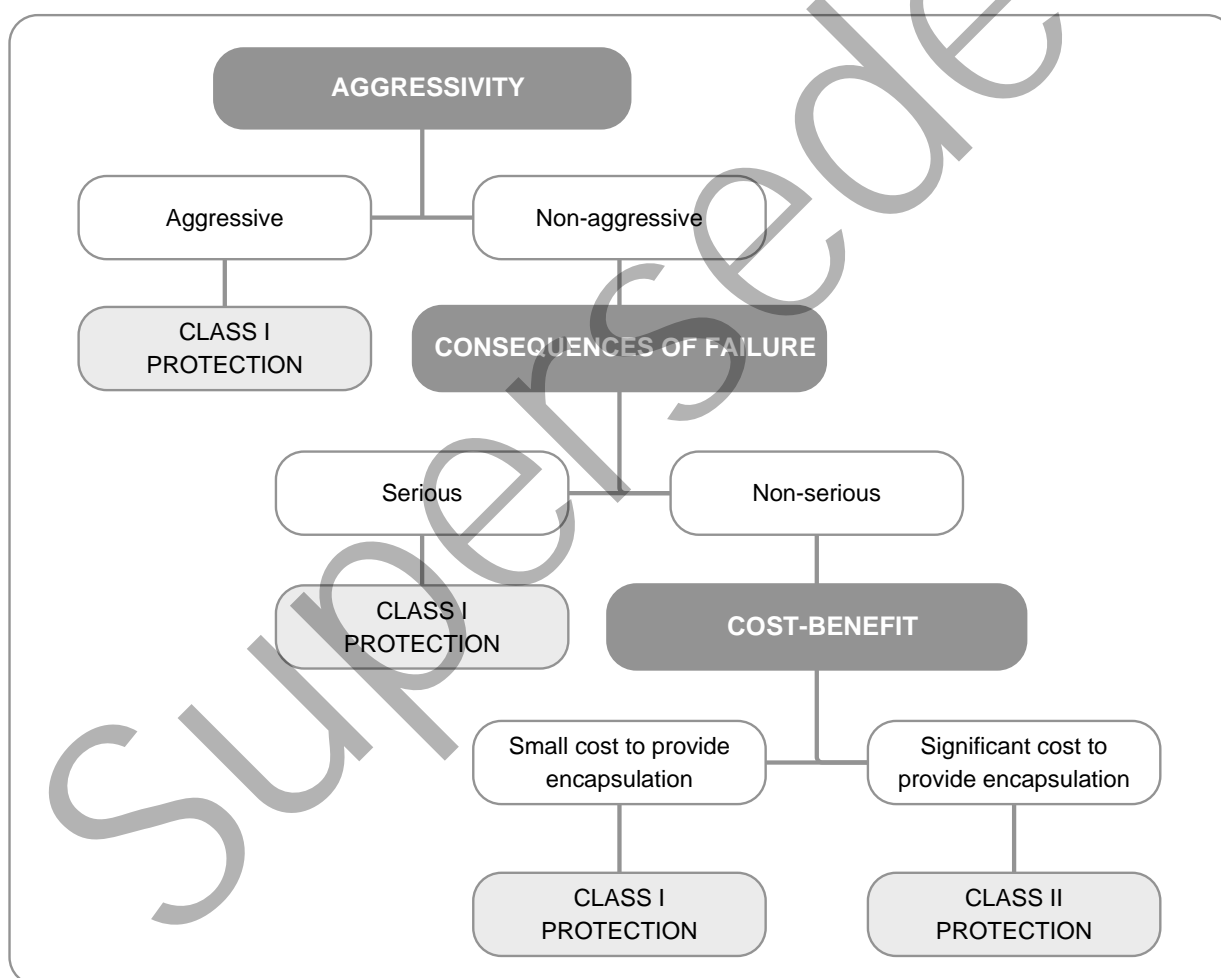

6.6.7 Soil-nailed walls

Soil-nailed walls shall be designed and constructed in accordance with appropriate design codes such as FHWA-SA-96-069R *Manual for the design and construction monitoring of soil nailed walls*⁽⁵⁶⁾, except as provided for in this *Bridge manual*.

Soil-nailed walls are acceptable subject to the following criteria:

- a. Soil nailing shall be carried out only on drained slopes free of groundwater, or with an adequate level of drainage to ensure that the facing and the soil-nailed block are fully drained.
- b. Soil-nailed walls shall not support abutments of bridges, except where it can be demonstrated that the deformation associated with mobilisation of the soil nail capacities, or any displacements associated with earthquakes can be tolerated or catered for in the design of the bridge structure.
- c. Overall limited block displacement in strong earthquakes may be allowed subject to the criteria in 6.6.9.
- d. Soil nails shall only be allowed to intrude into property outside the road reserve, if subsurface rights for the design life of the structure are obtained to prevent disturbance of the reinforced soil block by future subsurface (eg foundation, drainage) construction activities.
- e. The soil nail reinforcement shall be subject to the corrosion protection requirements specified in 6.6.6 for anchors.
- f. Pull-out tests shall be specified to be carried out on trial soil nails to be installed prior to the final wall anchors being constructed. The pull-out tests shall be used to confirm the design grout-ground bond strengths. The number of tests shall be chosen and specified by the designer based on the variability of the ground conditions and the number of anchors required.
- g. On-site suitability tests shall be carried out on a selected number of production soil nails as per BS EN 1537⁽⁵⁰⁾ to confirm the performance of the soil nails and their suitability to ensure performance of the wall. A small number of representative full-scale soil nails shall be installed and tested to confirm the suitability and performance of the soil nails, prior to installation of the remainder of the soil nails.
- h. On-site acceptance tests shall be carried out in accordance with BS EN 1537⁽⁵⁰⁾ on at least 25% of all installed soil nails. A higher proportion of nails shall be tested if the ground conditions are variable and the consequences of failure are high.

If there is any reason for concern about the long-term performance of soil nails and/or their ability to achieve the required design working life, the designer shall provide for future inspection, re-testing and replacement.

The designer shall consider the long term maintenance of soil nails and all elements forming part thereof. Where individual components (for example any associated nail head assembly) have a working life less than the design working life, the designer shall detail replacement methodology in the inspection and maintenance requirements section of the structure or soil structures report and within safety in design documentation.

6.6.8 Reinforced soil walls and slopes

Reinforced soil walls and slopes usually comprise either 'inextensible' (usually steel) or 'extensible' (usually geogrid) reinforcement. Reference should also be made to requirements with respect to earthquake design given in 6.6.9.

The following criteria shall be used in the design and construction of reinforced soil walls and slopes:

- a. Inextensible (steel) reinforcement shall be used for reinforced soil walls and slopes supporting bridge abutments or where limiting the deformation of the wall is critical due to the presence of adjacent structures. Geogrid reinforcement may be used, provided that the bridge abutment seat is supported on piles, and the design, including pile design, takes into account the expected deformation of the wall system.
- b. Design of geosynthetic-reinforced structures shall comply with appropriate design codes or manuals such as the recommendations of the NZTA research report 239 *Guidelines for design & construction of geosynthetic-reinforced soil structures in New Zealand*⁽⁵⁷⁾, except as otherwise provided in this manual.
- c. The long-term durability, strength and creep performance of the reinforcement, and the environmental conditions associated with the site, backfill and groundwater shall be considered in the selection and use of appropriate types of reinforcement and backfill.

In considering the rate of corrosion of the buried steel reinforcement, guidance may be obtained from AS/NZS 2041.1 *Buried corrugated metal structures* part 1 Design methods⁽⁵⁸⁾, and from the New Zealand Heavy Engineering Research Association (HERA) report R4-133 *New Zealand steelwork corrosion and coatings guide*⁽⁵⁹⁾.

- d. Steel reinforcement shall have an adequate level of corrosion protection and/or sacrificial steel content to ensure the required performance over the design working life of the structure.
- e. The strength of the connections between the soil reinforcement and the facing panels or blocks of reinforced soil walls shall exceed by a suitable margin the upper bound pull-out strength of the reinforcement through granular fill, or the post-yield over-strength capacity of the reinforcement, whichever is lower. Design shall ensure that brittle failures of the connections will not occur.
- f. Any capping blocks provided shall be adequately fixed in position to resist dislodgement due to earthquake actions or vandalism.

6.6.9 Design performance of earth retaining structures and slopes

- a. Permanent displacement of earth retaining structures and slopes in earthquakes
Earth retaining structures and slopes may be designed to remain elastic under the design earthquake load specified in 6.2.2 or to allow limited controlled permanent outward horizontal displacement under strong earthquake shaking.

Walls designed on the basis of permissible permanent outward horizontal displacement under strong earthquake shaking shall comply with all relevant recommendations of the Road Research Unit bulletin 84⁽³⁾.

The horizontal displacement likely at the design damage control limit state seismic response, and under the collapse avoidance limit state seismic response, shall be assessed using moderately conservative soil strengths consistent with the anticipated strain and a Newmark Sliding Block displacement approach.

Displacements may be assessed using the methods described by Ambraseys and Srbulov⁽⁵⁾, or Jibson⁽⁶⁾ or as outlined in *Earthquake geotechnical engineering practice*, module 3⁽⁸⁾ using the relevant peak ground accelerations (see 6.2), and the distance to the dominant earthquake sources in the area.

6.6.9 continued

Where a Newmark sliding block method is applied, the 50th percentile displacements shall be derived for both the damage control limit state and the collapse avoidance limit state events. At least three different commonly accepted methods for the assessment of the displacement shall be used and the range of predicted displacements (rather than a single value) should be used in the design process. In general, the upper bound values should be adopted unless a lesser value is otherwise justified and accepted by the road controlling authority.

Vertical accelerations shall be taken into consideration in the design of retaining structures. The energy and frequency content of earthquake shaking as well as the vertical earthquake motions (which tend to be high particularly in near field situations) have a significant effect on retaining wall performance in strong earthquakes. The effects of vertical shaking have been observed in recent earthquakes as well as in research sponsored by the Earthquake Commission Research Foundation (Brabhaharan et al, 2003⁽⁶⁰⁾). (Vertical accelerations of up to 2.2g were observed in the Christchurch earthquake of 22 February 2011.)

The uncertainty in the assessment of wall and slope horizontal displacements using peak ground accelerations shall be taken into consideration in the assessment of likely wall and slope displacements, although the peak ground acceleration based estimates remain the only quantitative estimation methods currently available.

In the design of earth retaining structures and slopes that are allowed limited permanent outward horizontal displacement in the design earthquake:

- i. The soil strength parameters used for assessment of sliding horizontal displacement shall be large strain soil strength parameters (and not peak strengths), consistent with large soil strains from the predicted displacements.
- ii. The probable ranges of soil parameters shall be considered when estimating the upper and lower bounds of threshold acceleration to cause wall or slope horizontal displacement.
- iii. Walls shall be proportioned to ensure sliding, rather than overturning or internal instability (in the case of MSE structures).
- iv. The expected horizontal displacement due to the design earthquake shall not encroach into minimum clearances from road carriageways and railway tracks or infringe property boundaries, or cause damage to services that may exacerbate movements or cause instability.
- v. It shall be recognised that, in near-field situations, the vertical accelerations associated with strong earthquake shaking would lead to larger horizontal displacements than assessed using peak ground accelerations alone. The design shall cater for larger horizontal displacements than those predicted using horizontal peak ground accelerations alone, to account for the effect of vertical seismic accelerations.
- vi. The assessed likely horizontal displacements and settlements of the structure or slope that would arise from sliding due to the design earthquake shall not exceed the values given in 6.1.2.

6.6.9 continued

b. Walls and earth structures (including slopes) supporting abutments or piers

Subject to obtaining the agreement of the road controlling authority, where the bridge abutment and superstructure can be designed to remain serviceable with limited abutment displacement and without damage to the bearings or piles, and can retain adequate allowance for temperature change, vibration etc, walls or earth retaining structures supporting abutments or piers may be designed on the basis of sustaining permanent displacement not exceeding the limits specified in 6.1.2 under the design damage control limit state earthquake event subject to the limitations below. This shall be substantiated in the structure design statement, which shall include quantification of the damage due to the movements and the consequences for the use of the bridge and its permanent repair to full capacity for design loading and movements.

These displacements limits shall apply to displacements determined in accordance with 6.3.2 and 6.6.9(a).

In addition:

- where the structure has non-integral abutments, the clearance between the abutment back wall and the end of the end span main girders in the longitudinal direction shall be sufficient to accommodate 2.0 times the full damage control limit state seismic movement of the bridge superstructure plus one third of the thermal movement, plus 200% of the assessed 50th percentile permanent abutment displacements. The abutment back wall shall be designed to accommodate reinstatement of the knock-off element at a position displaced further back from its original position by an amount of 200% of the abutment permanent displacement due to the design damage control limit state earthquake event, without need to strengthen or reconstruct the abutment back wall. The same general principles shall be applied during consideration of the transverse earthquake loads.
- Where the bridge is supported by piles and columns at the abutments, the piles and columns shall be protected from displacement of the wall, earth retaining structure or slope, for example by use of a sleeve with adequate space to accommodate the greater of the 50th percentile collapse avoidance limit state event displacement and 200% of the assessed 50th percentile seismic displacement arising from one damage control limit state design intensity earthquake. Alternatively the bridge shall be capable of withstanding the greater of the force applied by soil translating past the piles and columns due to a CALS event and the forces applied by two sequential DCLS design earthquake events. CALS major earthquake (ie an event with a return period significantly greater than the design event) performance criteria shall apply to structures subjected to these loading conditions.

c. Gravity and reinforced concrete cantilever walls

Gravity and reinforced concrete cantilever walls may be designed so that either:

- the wall remains elastic and does not suffer any permanent displacement under the design earthquake load specified in 6.2.2 and 6.2.3, or
- limited permanent outward movement due to soil deformation is accepted (see 6.6.9(a)) and the wall is designed to avoid yielding of the structural elements wherever practicable. In this case provision shall be made to accommodate the calculated displacement with minimal damage, and without encroaching on clearances. Walls other than those supported on piles shall be proportioned to slide rather than rotate. Due account shall be taken of the probable range of soil strength when estimating the upper and lower bounds of the threshold acceleration to cause wall displacement. The resistance to overturning shall be greater than 1.25 times the overturning moment derived from the upper bound combination of forces that act to cause sliding.

6.6.9 continued

d. Anchored walls

Anchored walls shall be designed to remain elastic under the seismic loading specified in 6.2.2 and 6.2.3. Consideration shall be given to the consequences of anchor and wall flexibilities under design conditions. Walls shall be detailed to ensure that under seismic overload, controlled displacement of the wall will occur through yielding of the anchor material, and sudden failure will be avoided. All anchors bars shall have ductile post-yield behaviour up to at least 5% strain.

Particular attention shall be given to the post-earthquake effectiveness of the anchor corrosion protection.

e. Mechanically stabilised earth walls

The Road Research Unit bulletin 84⁽³⁾ provides a basis for the seismic design of MSE walls and shall be complied with. The NZTA research report 239⁽⁵⁷⁾ also provides guidelines for the seismic design of such walls.

Section 6.6.7 provides guidance on the design of soil-nailed walls and design codes such as FHWA-SA-96-069R⁽⁵⁶⁾ also provide guidance.

A wall required to avoid permanent displacement shall be designed to remain elastic and stable under the design loading specified in 6.2.2.

The connection strengths between the reinforcements and the facing shall be such that the failure under earthquake overload is always ductile, that is, by either pull out of the reinforcement through granular materials without loss of pull-out capacity with displacement, or by yielding or deformation of the reinforcement, and not by failure of the connections. The strength margin over connection failure shall be at least 1.3.

A wall intended to undergo permanent displacement shall be designed so that the outward movement results from block sliding of the reinforced block as a whole and not due to internal instability or pull out of the reinforcement.

Using strip reinforcement, under earthquake overload, deformation shall preferably be by pull out of the reinforcement strips or, where this is impractical, by ductile extension of the reinforcement strips.

Where design is for pull-out, the nominal strength of the connection between the reinforcement and the wall facing shall be at least twice the pull-out force calculated from the probable apparent coefficient of friction. Upper and lower bounds of the threshold acceleration required to produce incipient failure shall be calculated by considering the reinforcement acting both horizontally and along the failure surface and allowing for probable variations in the pull-out resistance and yield strength of the reinforcement. Stability shall be checked under the upper bound acceleration. Design displacements shall not encroach on required clearances.

Using grid reinforcement, particularly geogrids with closely spaced transverse members, under earthquake overload, any internal deformation shall be through ductile elongation of the reinforcement rather than pull out of the reinforcement through the soil.

6.7 Geofoam road embankments

Geofoam is any manufactured geosynthetic material produced by an internal expansion process that results in a material with a texture of numerous, closed, gas-filled cells using either a fixed plant or an in situ expansion process. Expanded polystyrene-block (EPS-block) geofoam is a material that is widely used as lightweight fill in road construction.

The following documents provide guidance on the design of geofoam applications on roading projects:

- *Guidelines for geofoam applications in slope stability projects*⁽⁶¹⁾
- *Guideline and recommended standard for geofoam applications in highway embankments*⁽⁶²⁾
- *Geofoam applications in the design and construction of highway embankments*⁽⁶³⁾.

6.8 Geosynthetic soil reinforcement

6.8.1 Product approval

Geosynthetic soil reinforcement and systems employed in the reinforcement of soil structures (embankments, slopes, reinforced soil walls, etc) are relatively new materials with widely varying properties and a relatively limited history of application and proven performance.

Where geosynthetic soil reinforcement is proposed to be used, the specific geosynthetic reinforcement material and supplier shall be subject to the approval of the road controlling authority. Documentation to be submitted in support of an application for approval shall include the following:

- For geosynthetic reinforced soil wall (GRS) systems and their components (including geosynthetic reinforcement):
 - GRS system or component development and the year it was commercialised.
 - GRS system or component supplier organisational structure, engineering and construction support staff.
 - Limitations and disadvantages of the system or component.
 - A representative list of previous and current projects with the same application in areas with similar seismicity, as well as the names of the project owners, including names, addresses and telephone numbers of representatives of the owners who hold the authority to provide references on behalf of the owner.
 - Sample material and control specifications showing material type, quality, certification, test data, acceptance and rejection criteria and placement procedures.
 - A documented field construction manual.
 - Design calculations and drawings for the proposed application.
- For geosynthetic reinforcement, the following additional information is also required:
 - Polymer and additive composition of the geosynthetic material, including polymer and additive composition of any coating materials.
 - Past practical applications of the geosynthetic material use with descriptions and photos.

6.8.1 continued

- Limitations and disadvantages of the geosynthetic material.
- Sample long-term design strength and interaction values, and index property specifications.
- Laboratory test results documenting creep performance over a range of load levels, for a minimum duration of 10,000 hours.
- Laboratory test results, along with a comprehensive literature review, documenting extrapolation of creep data to a 100-year design life.
- Field and laboratory test results, along with a literature review, documenting reduction factors for installation damage.
- Laboratory test results and extrapolation techniques, along with a comprehensive literature review, documenting chemical resistance of all material components of the geosynthetic and reduction factors for chemical degradation.
- Susceptibility of the geosynthetic to degradation by hydrolysis, which may lead to premature failure.
- Where a potential for biological degradation exists, laboratory test results, extrapolation techniques, along with a comprehensive literature review, documenting biological resistance of all material components of the geosynthetic and reduction factors for biological degradation.
- Laboratory test results documenting the test method and the value of short-term strength.
- Laboratory test results documenting joint (seams and connection) strength and values for reduction factor for joints and seams.
- Laboratory tests documenting long-term pull-out interaction coefficients for the project site-specific soils.
- Laboratory tests documenting the direct sliding coefficients for various soil types or for the project site-specific soils.
- Robustness of the geosynthetic against damage during construction, including test results for use with similar reinforced fill materials as proposed, and adequate junction strength in the case of geogrids.
- The manufacturing quality control programme and data indicating minimum test requirements, test methods, test frequency etc. Minimum conformance requirements shall be indicated. Data shall be from a laboratory qualified and registered by IANZ for the testing. Data from an equivalent international laboratory may also be accepted, at the discretion of the road controlling authority.
- The reduction factors applied in the design. These shall be as recommended by the manufacturer/supplier (based on product-specific testing) or a combination of manufacturer/supplier recommended values and default values recommended by the NZTA research report 239⁽⁵⁷⁾.

The approval by the road controlling authority should include establishment of a set of index criteria for the purpose of quality assurance testing during construction (refer to 6.8.3).

6.8.2 Material properties

The geosynthetic reinforcement shall be a regular network of integrally connected polymer tensile elements with aperture geometry sufficient to permit significant mechanical interlock with the surrounding soil or rock. The geosynthetic reinforcement structure shall be dimensionally stable and able to retain its geometry under construction stresses and shall have high resistance to damage during construction, to ultraviolet degradation, and to all forms of chemical and biological degradation encountered in the soil being reinforced. The geosynthetic reinforcement shall be sufficiently durable to ensure that it continues to fulfil its intended function throughout the design life of 100 years.

The geosynthetic reinforcement shall have a design tensile strength, pull-out and direct shear parameters and other properties adequate to satisfy the performance requirements of earth structure in which it is being utilised.

The permeability of the geosynthetic reinforcement shall be greater than the permeability of the fill soil in which it is being placed.

6.8.3 Quality assurance and index properties

Each roll of product shall be labelled with unique identifiers that allow traceability back to the manufacturer and thereby the manufacturing process. Records of product used including the location, level and batch/lot number shall be kept and incorporated into maintenance documentation,

Testing procedures for measuring design properties require elaborate equipment, tedious set-up procedures and long durations for testing. These tests are inappropriate for quality assurance (QA) testing of geosynthetic reinforcements received on site. A series of index criteria shall be established for QA testing of geosynthetic reinforcement materials received on site during construction. These index criteria should include mechanical and geometric properties that directly impact the design strength and soil interaction behaviour of the geosynthetics.

6.9 References

- (1) Standards New Zealand NZS 1170.5:2004 *Structural design actions*. Part 5 Earthquake actions - New Zealand. (Incorporating Amendment No. 1: 2016)
- (2) NZ Transport Agency (2009) *Procurement manual: for activities funded through the National Land Transport Programme*, Procurement manual tools, Latest values for 1991 infrastructure cost indexes. Last accessed 28 September 2018
<www.nzta.govt.nz/assets/resources/procurement-manual/docs/latest-values-for-1991-infrastructure-cost-indexes-new-presentation.xls>.
- (3) Wood JH and Elms DG (1990) *Seismic design of bridge abutments and retaining walls*. Road Research Unit bulletin 84, volume 2. NZ Transport Agency, Wellington.
- (4) Murashev AK, Kirkcaldie DK, Keepa C, Cubrinovski M and Orense R (2014) *Development of the design guidance for bridges in New Zealand for liquefaction and lateral spreading effects*. Research report 553, NZ Transport Agency, Wellington.
- (5) Ambraseys N and Srbulov M (1995) *Earthquake induced displacements of slopes*. Soil Dynamics and Earthquake Engineering volume 14.
- (6) Jibson RW (2007) *Regression models for estimating co-seismic landslide displacements*. Engineering Geology, 91.
- (7) Bray JD and Travasarou T (2007) *Simplified procedure for estimating earthquake-induced deviatoric slope displacements*. Journal of Geotechnical and Geoenvironmental Engineering, 133(4), 381-392pp.
- (8) New Zealand Geotechnical Society and Ministry of Business Innovation & Employment (2016) *Earthquake geotechnical engineering practice*. Module 3 - Identification, assessment and mitigation of liquefaction hazards. Wellington.
- (9) ASTM D4428/D4428M-14 (2014) *Standard test methods for crosshole seismic testing*. ASTM International, West Conshohocken, PA, USA.
- (10) ASTM D5777-00(2011) *Standard guide for using the seismic refraction method for subsurface investigation*. ASTM International, West Conshohocken, PA, USA.
- (11) Taylor ML, Cubrinovski M and Haycock I (2012) *Application of new 'Gel-push' sampling procedure to obtain high quality laboratory test data for advanced geotechnical analyses*. Proceedings of the 2012 NZSEE Annual Technical Conference, New Zealand Society for Earthquake Engineering, Christchurch.
- (12) Hofmann BA and Robertson PK (2000) *In situ ground freezing to obtain undisturbed samples of loose sand for liquefaction assessment*. Journal of Geotechnical and Geoenvironmental Engineering, 126(11), 979-989pp.
- (13) ASTM D5778-12 (2012) *Standard test method for electronic friction cone and piezocone penetration testing of soils*. ASTM International, West Conshohocken, PA, USA.
- (14) ASTM D1586-11 (2011) *Standard test method for standard penetration test (SPT) and split-barrel sampling of soils*. ASTM International, West Conshohocken, PA, USA.

- (15) ASTM D6066-11 (2011) *Standard practice for determining the normalized penetration resistance of sands for evaluation of liquefaction potential*. ASTM International, West Conshohocken, PA, USA.
- (16) Boulanger RW and Idriss IM (2006) *Liquefaction susceptibility criteria for silts and clays*. Journal of Geotechnical and Geoenvironmental Engineering, 132(11), 1413-1426pp.
- (17) Boulanger RW and Idriss IM (2007) *Evaluation of cyclic Softening in silts and clays*. Journal of Geotechnical and Geoenvironmental Engineering, 133(6), 641-652pp.
- (18) Bray JD and Sancio RB (2006) *Assessment of the liquefaction susceptibility of fine-grained soils*. Journal of Geotechnical and Geoenvironmental Engineering, 132(9), 1165-1177pp.
- (19) Boulanger RW and Idriss IM (2014) *CPT and SPT based liquefaction triggering procedures*. Report no. UCD/CGM-14/01, Centre for Geotechnical Modelling, Dept. of Civil & Environmental Engineering, University of California at Davis, CA, USA.
- (20) Ishihara K and Yoshimine M (1992) *Evaluation of settlements in sand deposits following liquefaction during earthquakes*. Soils and Foundations, vol.32, no.1, pp.173-188
- (21) Zhang G, Robertson PK, and Brachman RWI (2002) *Estimating liquefaction-induced ground settlements from CPT for level ground*. Canadian Geotechnical Journal, 2002, 39(5).
- (22) Bray JD and Dashti S (2012) *Liquefaction induced building movement*. Proceedings of 2nd International Conference on Performance Based Design in Earthquake Geotechnical Engineering, Taormina, Italy.
- (23) Murashev AK, Keepa C and Tai A (2015) *Performance based design of a structural foundation on liquefiable ground with a natural soil crust*. Proceedings of the 6th International Conference on Earthquake Geotechnical Engineering, Christchurch.
- (24) Tokimatsu K and Asaka Y (1998) *Effects of liquefaction-induced ground displacements on pile performance in the 1995 Hyogoken-Nambu earthquake*. Soils and Foundations, Special Issue no. 2, September 1998: 163-177pp.
- (25) Youd TL, Hansen CM and Bratlett SF (2002) *Revised multilinear regression equations for prediction of lateral spread displacement*, Journal of Geotechnical and Geoenvironmental Engineering, 128(12), 1007-1017pp.
- (26) Zhang G, Robertson PK and Brachman RWI (2004) *Estimating liquefaction-induced lateral displacements using the standard penetration test or cone penetration test*. Journal of Geotechnical and Geoenvironmental Engineering, 130(8), 861-871 pp.
- (27) Olson SM and Johnson CI (2008) *Analyzing liquefaction -induced lateral spreads using strength ratios*. Journal of Geotechnical and Geoenvironmental Engineering, 134(8), 1035-1049pp.
- (28) Ishihara K (1985) *Stability of natural deposits during earthquakes*. Proceedings of 11th International Conference on Soil Mechanics and Foundation Engineering, A.A. Balkema Publishers, Rotterdam, Netherlands.
- (29) Tamura S and Tokimatsu K (2005). *Seismic earth pressure acting on embedded footing based on large-scale shaking table tests*. American Society of Civil Engineers Geotechnical Special Publication 145, 83-96pp.

- (30) Ashford SA, Boulanger RW and Brandenberg SJ (2011) *Recommended design practice for pile foundations in laterally spreading ground*. PEER Report 2011/04 Pacific Earthquake Engineering Research Center, College of Engineering, University of California, Berkeley, CA, USA.
- (31) Marcuson WF, Hynes ME and Franklin AG (1990) *Evaluation of the use of residual strength in seismic safety analysis of embankments*. Earthquake Spectra, 6(3), 529-572pp.
- (32) Ardoino F, Bertalot D, Piatti C and Zanolli O (2015) *Effect of pore pressure build-up on the seismic response of sandy deposits*. Frontiers in Offshore Geotechnics III - Meyer (Ed.). Taylor & Francis Group, London, UK.
- (33) Murashev AK, Keepa C, Cubrinovski M (2018) *Analysis of piled bridges at sites prone to liquefaction and lateral spreading in New Zealand*. Report for NZ Transport Agency.
- (34) New Zealand Geotechnical Society and Ministry of Business Innovation & Employment (2017) *Earthquake geotechnical engineering practice*. Module 5 - Ground improvement of soils prone to liquefaction. Wellington.
- (35) New Zealand Society on Large Dams (2015) *Dam safety guidelines*. Wellington.
- (36) Parliamentary Counsel Office (1992) Building Regulations 1992. Schedule 1 *The building code*. Wellington.
- (37) Ministry of Business, Innovation & Employment (2016) *Acceptable solutions and verification methods for New Zealand building code clause B1 Structure*. Wellington.
- (38) British Standards Institution BS EN 1997-1:2004+A1:2013 *Eurocode 7 Geotechnical design part 1 General rules*.
- (39) British Standards Institution BS EN 1998-5:2004 *Eurocode 8 Design of structures for earthquake resistance part 5 Foundations, retaining structures and geotechnical aspects*.
- (40) Canadian Standards Association (2014) S6-14 *Canadian highway bridge design code*, and S6.1-14 *Commentary on S6-14 Canadian highway bridge design code*.
- (41) American Association of State Highway and Transportation Officials (2014) *LRFD Bridge design specifications, customary U.S. units, 7th edition*. Washington DC, USA.
- (42) Standards Australia AS 2159-2009 *Piling - Design and installation*.
- (43) American Association of State Highway and Transportation Officials (2011) *Guide specifications for LRFD seismic bridge design*. 2nd edition. Washington DC, USA.
- (44) Ministry of Business, Innovation & Employment (2016) *Acceptable solutions and verification methods for New Zealand building code clause F4 Safety from falling*. Wellington.
- (45) NZ Transport Agency (2016) *Highway structures design guide*. Wellington.
- (46) Standards Australia AS 4678-2002 *Earth-retaining structures*.
- (47) Munfakh GA, Samtami NC, Castelli RJ and Wang JN (1999) *Earth retaining structures*. Publication FHWA NHI-99-025, Federal Highway Administration of the US Department of Transport, Washington DC, USA.

- (48) Construction Industry Research and Information Association (2003) CIRIA C580 *Embedded retaining walls – guidance for economic design*. London, UK.
- (49) British Standards Institution BS 8081: 2015+A1:2017 *Code of practice for grouted anchors*.
- (50) British Standards Institution BS EN 1537:2013 *Execution of special geotechnical work – ground anchors*.
- (51) Federal Highway Administration (1999) *Ground anchors and anchored systems*. Geotechnical Engineering Circular 4, publication FHWA-IF-99-015, US Department of Transportation, Washington DC, USA.
- (52) Standards Australia and Standards New Zealand jointly AS/NZS 4680:2006 *Hot-dip galvanized (zinc) coatings on fabricated ferrous articles*.
- (53) ASTM A934/A934M-16 (2016) *Standard specification for epoxy-coated prefabricated steel reinforcing bars*. ASTM International, West Conshohocken, PA, USA.
- (54) ASTM D3963/D3963M-15 (2015) *Standard specification for fabrication and jobsite handling of epoxy coated steel reinforcing bars*. ASTM International, West Conshohocken, PA, USA.
- (55) Federal Highway Administration (1998) *Design manual for permanent ground anchor walls*. Publication FHWA-RD-97-130, US Department of Transportation, Washington DC, USA.
- (56) Federal Highway Administration (1998) *Manual for the design and construction monitoring of soil nailed walls*. Publication FHWA-SA-96-069R, US Department of Transportation, Washington DC, USA.
- (57) Murashev AK (2003) *Guidelines for design & construction of geosynthetic-reinforced soil structures in New Zealand*. Research report 239, NZ Transport Agency, Wellington.
- (58) Standards Australia and Standards New Zealand jointly AS/NZS 2041.1:2011 *Buried corrugated metal structures part 1 Design methods*.
- (59) New Zealand Heavy Engineering Research Association (2011) *New Zealand steelwork and corrosion coatings guide*. Report R4-133, Manukau City.
- (60) Brabhaharan P, Fairless GJ and Chapman HE (2003) *Effect of vertical earthquake shaking on displacement of earth retaining structures*. Proceedings of the Pacific conference on earthquake engineering, New Zealand Society for Earthquake Engineering, Christchurch.
- (61) National Cooperative Highway Research Program (2011) *Guidelines for geofoam applications in slope stability projects*. Final report for project no. 24-11(02), Transportation Research Board, Washington DC, USA.
- (62) National Cooperative Highway Research Program (2004) *Guideline and recommended standard for geofoam applications in highway embankments*. Report 529, Transportation Research Board, Washington DC, USA.
- (63) National Cooperative Highway Research Program (2004) *Geofoam applications in the design and construction of highway embankments*. Web document 65 (Project 24-11), Transportation Research Board, Washington DC USA.

(This page is intentionally blank)

Superseded

7.0 Evaluation of bridges and culverts

In this section

	Section	Page
7.1	Introduction	7-2
7.2	Inspection and dynamic load factors	7-5
7.3	Material strengths	7-6
7.4	Main member capacity and evaluation	7-11
7.5	Deck capacity and evaluation	7-18
7.6	Proof loading	7-24
7.7	References	7-28

7.1 Introduction

7.1.1 General

a. Objective

The objective of evaluation of an existing bridge, culvert, stock underpass or subway is to obtain parameters which define its load carrying capacity. Two parameters are required – one for main members and one for the deck.

The overall procedure is summarised in 7.1.5. The process shall take account of the actual condition of the structure and the characteristics of the traffic and other loads. If at some future date any of the conditions change significantly, the structure shall be re-evaluated accordingly.

b. Rating and posting

Evaluation may be carried out at four load levels (see definitions in 7.1.2):

- Rating evaluation

Rating parameters define the structure's capacity using overload load factors or stress levels that are appropriate for overweight vehicles.

- Posting evaluation

Posting parameters define the structure's capacity using live load factors or stress levels that are appropriate for general access vehicles.

- HPMV evaluation

HPMV evaluation defines the structure's capacity under the effects of high-productivity motor vehicle (HPMV) conforming vehicles using the same live load factors or stress levels as posting.

- 50MAX evaluation

50MAX evaluation defines the structure's capacity under the effects of 50MAX conforming vehicles using the same live load factors or stress levels as posting.

Because much of the procedure is identical for these types of evaluation, the criteria are presented together and where appropriate, the different procedures are set out side by side on the page.

c. Culverts, stock underpasses and subways

Culverts, stock underpasses and subways shall be treated on the same basis as bridges (with generally no distinction being made in this section 7), except that further evaluation of a culvert stock underpass or subway is not required, provided the following apply:

- it has a span less than 2m, and
- it has more than 1m of fill over it, and
- it is undamaged, and
- there are no unusual circumstances.

For most culverts, stock underpasses and subways, evaluation of the top slab as a deck will be sufficient.

7.1.2 Definitions

Class I vehicle: A vehicle that is able to travel on Class I roads as defined in section 3: *Classification of roads* of the Heavy Motor Vehicle Regulations 1974⁽¹⁾ without restriction. (Note that this is an archaic term but it is still in use for bridge posting limits.)

7.1.2 continued

General access vehicle:	A vehicle that is loaded to the axle mass and total mass limits set out in parts 1 and 2 respectively of schedule 3 in the Land Transport Rule: Vehicle Dimensions and Mass 2016 ⁽²⁾ and is thus able to operate without a permit, subject to any specific route or bridge restrictions.
50MAX conforming vehicle:	A proforma vehicle that is loaded to the axle mass and total mass limits set out for general access vehicles in parts 1 and 2 of schedule 3 in the Land Transport Rule: Vehicle Dimensions and Mass 2016 ⁽²⁾ , but with table 2.1 thereof amended to allow a vehicle mass varying linearly between 44,000kg at 16.5m wheelbase to a maximum of 50,000kg at 20.0m wheelbase. This is a variant high-productivity motor vehicle.
50MAX evaluation load:	A load consisting of 50MAX conforming vehicles in some or all load lanes on the bridge, taken to be: <ul style="list-style-type: none"> • for loaded lengths up to and including 25m: 0.85HN, including dynamic load factors, and • for loaded lengths greater than 25m: 0.90HN, including dynamic load factors. See 7.4.4 for further details.
HPMV conforming vehicle:	A vehicle carrying a divisible load that is loaded to the axle mass and total mass limits set out for high-productivity motor vehicles (HPMVs) in parts 3 and 4 respectively of schedule 3 in the Land Transport Rule: Vehicle Dimensions and Mass 2016 ⁽²⁾ .
HPMV evaluation load:	A load consisting of HPMV conforming vehicles in some or all load lanes on the bridge, taken to be: <ul style="list-style-type: none"> • for loaded lengths up to and including 25m: 0.90HN, including dynamic load factors, and • for loaded lengths greater than 25m: 0.95HN, including dynamic load factors. See 7.4.4 for further details.
Live load capacity:	The section capacity, in terms of the net unfactored service load, of a critical member or group of members at load factors, or stress limits appropriate to conforming vehicles. See 7.4.2.
Load lane:	Lanes used for the positioning of elements of live loading on the bridge. The number of load lanes shall generally equal the number of marked lanes on the bridge. See 7.4.4 for further details.
Loaded length:	The length over which loads may be applied. See 7.4.4 for further details.
Overload capacity:	The section capacity, in terms of the net unfactored service load, of a critical member or group of members at load factors, or stress limits appropriate to overweight vehicles. See 7.4.2.
Overweight vehicle:	A vehicle carrying an indivisible load that exceeds the load limits set out in the Land Transport Rule: Vehicle Dimensions and Mass 2016 ⁽²⁾ and therefore requires an overweight permit.
Posting:	The proportion of the general access vehicles posting load which the bridge can withstand under live load criteria. It is expressed as a percentage of Class I (in effect percentage of general access vehicle mass limits) for main members and as a specific axle load for decks.

7.1.2 continued	Posting load:	A load consisting of general access vehicles in some or all load lanes on the bridge, taken to be 0.85HN, including dynamic load factors. See 7.4.4 for further details.
	Rating:	The proportion of the rating load which the bridge can withstand under overload criteria. It is expressed as a percentage, defined as the class for main members, and an alphabetic symbol defined as the grade for decks.
	Rating load:	A load consisting of one lane containing an overweight vehicle loaded to the maximum which would be allowed to cross a Class 100 Grade A bridge unsupervised, as set out in the <i>Overweight permit manual</i> ⁽³⁾ (taken as 0.85HO), plus, where critical, some or all other load lanes on the bridge loaded with HPMV evaluation load including dynamic load factors. See 7.4.4 for further details.
	Specialist vehicle:	A vehicle of certain specialised types carrying a divisible load, as defined in clause 5.11(2) in section 1 of part 1 in the Land Transport Rule: Vehicle Dimensions and Mass 2016 ⁽²⁾ . A variant high-productivity motor vehicle and evaluated as such.

7.1.3 Rating requirements

- a. These requirements apply to all bridges, major culverts (greater than 3.4m² waterway), stock underpasses and subways on roads controlled by authorities participating in the NZ Transport Agency's (NZTA) policy for overweight permits as set out in the *Overweight permit manual*⁽³⁾. This requires an inventory of structural capacity for overload to be maintained for each of these structures. This is expressed as the rating, defined in 7.1.2. By comparing a specific overweight vehicle with the rating load, and use of the structure rating, an estimate of the effect of the vehicle on the structure can be made, as described in the *Overweight permit manual*⁽³⁾.

In the case of state highways and some of the major alternative routes, the inventory is in the form of basic moment and shear, or other capacities of bridge members stored in the overweight permit system (OPermit)⁽⁴⁾. This enables the effects of a specific overweight vehicle on any bridge to be determined more accurately than by use of the rating alone.

- b. The procedures set out in section 7 are intended to be used for existing bridges which require evaluation. New bridges designed to HN-HO-72, and fully complying with the design requirements of this document, also require rating and the methods could be used for this. However, unless rating information is readily available, or there are unusual circumstances, all new bridges shall be evaluated on their design capacities. Since the rating load is 0.85 times the design load, the class is $100/0.85 =$ (say) 120%, and the grade is A. Capacities entered into OPermit should be the design values of HO or HO + HN moment, shear or other parameters as appropriate, with dynamic load factors and eccentricity.

7.1.4 Posting requirements

If a bridge has insufficient capacity to sustain axle masses and total load masses up to the maximum allowed for general access vehicles specified in parts 1 and 2 respectively of schedule 3 of the Land Transport Rule: Vehicle Dimensions and Mass 2016⁽²⁾ at normal live load factors or stress levels, or at higher stress levels as permitted by 7.4.3, it is required to be posted with a notice showing its allowable load, or posting, as defined in 7.1.2.

Posting of a bridge shall comply with section 11: *Protection of bridges* of the Heavy Motor Vehicle Regulations 1974⁽¹⁾.

7.1.5 Evaluation procedure

The steps necessary for a full evaluation, either for rating or posting, are shown in table 7.1. Details of each step will be found in the clauses referenced.

The evaluation of bridges for their capacity for HPMVs and 50MAX vehicles shall adopt the same procedure as for a posting evaluation.

Table 7.1: Evaluation procedure

Step 1	Carry out site inspection (7.2.1).		
Step 2	Determine appropriate material strengths (7.3).		
Step 3	Identify critical section(s) of the main supporting members and the critical effect(s) on them (7.4.1).		
Step 4	Determine the overload capacity and/or the live load capacity at each critical main member section (7.4.2).		
Step 5	If rating is being done manually: <ul style="list-style-type: none"> Analyse the structure for effects of rating or posting load at each critical section (7.4.4). 	If data is to be entered into OPermit: <ul style="list-style-type: none"> Follow the requirements for main member element data in the <i>OPermit bridge structural data guide</i>⁽⁴⁾ (7.4.7). 	
Step 6	Determine rating or posting (7.4.6).		
Step 7	Concrete deck: <ul style="list-style-type: none"> Determine if the criteria for empirical design based on assumed membrane action are satisfied (7.5.2). Determine if the simplified evaluation method is applicable (7.5.3(a)). 	Timber deck	
Step 8	If simplified method is applicable: <ul style="list-style-type: none"> determine ultimate wheel load (7.5.3(b)). 	If simplified method is not applicable: <ul style="list-style-type: none"> determine section capacity per unit width at critical locations in slab (7.5.4(a)). 	Determine section capacity of the nominal width of deck considered to carry one axle (7.5.5(a)).
Step 9		Analyse the deck for rating or posting loads (7.5.4(b)).	Determine moments due to rating or posting axle loads (7.5.5(b)).
Step 10	Determine deck capacity factor (DCF) and/or allowable axle load. (7.5.3(c))	(7.5.4(c))	(7.5.5(c))
Step 11	If data is to be entered into OPermit, follow the requirements for deck element data in the <i>OPermit bridge structural data guide</i> ⁽⁴⁾ .		

7.2 Inspection and dynamic load factors

7.2.1 Inspection

Appropriate inspection shall be carried out as a part of the evaluation of the load carrying capacity of any bridge. This is required to determine member condition and to verify dimensions. Where necessary, the extent of corrosion or decay shall be determined by physical measurement.

The following significant characteristics of the carriageway and traffic shall be assessed:

- position of lane markings
- roughness of deck and approaches
- mean speed of heavy traffic
- heavy traffic type and proportion of the total vehicle count.

7.2.2 Dynamic load factors

Appropriate dynamic load factors shall be determined for the various bridge members. Each value shall be:

- either the design value from 3.2.5 or in the case of timber elements from 4.4.2, or
- a value derived from site measurements.

A measured value shall be used if the design value is considered to be unrealistic.

7.2.2 continued

Dynamic measurements shall be made under heavy loads which are representative of actual traffic, in terms of both mass and speed, at either rating load level or posting load level or both. A sufficient number of vehicles shall be included to give confidence in the statistical values chosen.

The dynamic load values derived shall be those which are exceeded by less than 5% of vehicles in either category.

For posting, HPMV and 50MAX evaluation, a reduced dynamic load factor may be used in the following instances:

- NZ Transport Agency state highways - as per posted speed limit
- other roads - as per posted speed limit, or as specified within the 50MAX or HPMV permit where the vehicle speed is restricted.

The dynamic load factor may be reduced as follows:

Speed	Dynamic load factor
30km/h	$(I - 1) \times 0.67 + 1$
10km/h	$(I - 1) \times 0.33 + 1$

Where **I** is the dynamic load factor appropriate for unrestricted heavy traffic.

7.3 Material strengths

Material strengths for calculation of section capacity shall be determined as described below. The strengths used shall be characteristic values as defined in the relevant material code, or as determined in 7.3.6. Where testing is undertaken a laboratory with IANZ accreditation for the test being undertaken or other appropriate agency shall be used. The basis of the material strengths used for determining section capacity shall be clearly stated in the evaluation calculations or any accompanying report.

7.3.1 Concrete

Concrete compressive strength shall be determined by one of the following methods:

- From drawings, specification or other construction records.
- From the following nominal historical values:

Construction date	Concrete type	Specified strength (MPa)
Up to 1932	Reinforced	14
1933 to 1940	Reinforced	17
1941 to 1970	Reinforced	21
1971 and later	Reinforced	25
1953 and later	Prestressed	34

- From cores cut from the bridge.

Cores shall be taken from areas of low stress, in the members being analysed, and so as to avoid reinforcing and prestressing steel. Cutting and testing shall be in accordance with NZS 3112.2 *Methods of test for concrete part 2 Tests relating to the determination of strength of concrete*⁽⁵⁾.

7.3.1 continued

Where core tests are carried out, the statistical analysis described in 7.3.6 shall be applied to determine the compressive strength value to be used in calculations.

7.3.2 Steel reinforcement

The characteristic yield strength of reinforcement shall be determined by one of the following methods. It should be noted that if the steel is of unusually high strength, sections may in fact be over-reinforced and the restriction referred to in 7.4.5(a) shall apply:

- a. From drawings, specification or other construction records.
- b. From the following nominal historical values:

Construction date	Characteristic yield strength (MPa)
Up to 1932	210
1933 to 1966	250
1967 and later	275

- c. From tensile tests of bar samples of appropriate diameter removed from the bridge members being analysed. Testing shall be in accordance with BS EN ISO 6892-1 *Metallic materials Tensile testing part 1 Method of test at room temperature*⁽⁶⁾.
- d. From non-destructive tests of bars of appropriate diameter in situ, after removal of cover concrete. The method used shall have been authenticated by correlation with tests in accordance with BS EN ISO 6892-1⁽⁶⁾.

Test locations shall be on the members being analysed, chosen so as to be unaffected by bends or welded splices in bars.

Where testing is performed as in (c) or (d), the statistical analysis described in 7.3.6 shall be applied to determine the characteristic value to be used in calculations. A separate analysis shall be performed for each bar diameter.

7.3.3 Prestressing steel

The characteristic ultimate tensile strength or the 0.2% proof stress of prestressing steel shall be determined by one of the following methods:

- a. From drawings, specification or other construction records.
- b. From the lowest alternative value specified by the most probably applicable standard specifications for the wire or strand diameter in force at the time of construction of the structure. Strengths specified by historical standard specifications and MWD design manuals are presented in C7.3.3 in the *Bridge manual commentary*.

7.3.4 Structural steel

The characteristic yield strength of structural steel shall be determined by one of the following methods:

- a. From drawings, specification or other construction records.
- b. From the following nominal historical values:

Construction date	Characteristic yield strength (MPa)
Up to 1940	210
1941 and later	230

- c. From tensile tests of coupons removed from the members being analysed, in areas of low stress. Testing shall be in accordance with BS EN ISO 6892-1⁽⁶⁾.
- d. From non-destructive tests of the steel in situ.

7.3.4 continued

Where testing is performed as in (c) or (d), the statistical analysis described in 7.3.6 shall be applied to determine the characteristic value to be used in calculations.

7.3.5 Timber

Characteristic stresses shall be in accordance with NZS 3603 *Timber structures standard*⁽⁷⁾, or where applicable, AS 1720.2 *Timber structures part 2 Timber properties*⁽⁸⁾ and AS/NZS 2878 *Timber – Classification into strength groups*⁽⁹⁾. Where the species of timber is unknown, it may be determined by removing 10mm diameter core samples from the bridge and submitting them for expert analysis.

Characteristic stresses shall be based either on the lowest grading of any member in the bridge, or on the actual grading of each timber member, according to the visual grading rules of NZS 3631 *New Zealand timber grading rules*⁽¹⁰⁾ or where applicable, AS 3818.6 *Timber – Heavy structural products – Visually graded part 6 Decking for wharves and bridges*⁽¹¹⁾, AS 3818.7 *Timber – Heavy structural products – Visually graded part 7 Large cross-section sawn hardwood engineering timbers*⁽¹²⁾ or AS 2858 *Timber – Softwood – Visually stress-graded for structural purposes*⁽¹³⁾. The moisture content shall be determined from core samples cut from the bridge.

Strength reduction factors and characteristic stress/strength modification factors shall comply with the applicable standard NZS 3603⁽⁷⁾, AS 5100.9 *Bridge design part 9 Timber*⁽¹⁴⁾ or AS 1720.1 *Timber structures part 1 Design methods*⁽¹⁵⁾, as specified by 4.4.2.

Determination of design stresses for timber is discussed in *Strength and durability of timber bridges*⁽¹⁶⁾.

7.3.6 Analysis of test results

In order to obtain characteristic strength values for calculation purposes, results of steel and concrete tests shall be analysed statistically. Each test result shall be the mean of tests on at least two samples taken from one location in the structure or the mean of two (or more as required by specific test procedures) non-destructive tests from one location on a bar or member. For analysis, a group of test results shall originate from similar members or from identical bar diameters as appropriate. Tests shall be taken at sufficient locations to ensure that results are representative of the whole structure, or the entire group of similar members, as appropriate.

When assessing how representative the test results are, consideration should be given to the spread and amount of sampling across the structural members being considered, and should take into account the possibility that materials in different spans may have been produced in different batches. Where possible, non-destructive testing should be carried out on the most critical members.

a. Estimating characteristic strength of materials functioning individually

An acceptable method of analysis to determine the characteristic strength of materials acting individually, such as concrete compressive strength, or the yield strength of individual reinforcing bars, is:

$$f_{\text{individual}} = \bar{X} - ks$$

Where:

$f_{\text{individual}}$ = the characteristic strength of the individual material

\bar{X} = the mean of the group of test results

k = a one-sided tolerance limit factor

s = the standard deviation of the test results

k shall be determined on the basis that at least a proportion (P) of the population will be greater than the value calculated, with a confidence (α).

7.3.6 continued

Values of k for various values of (P), (α) and (n) the number of test results, are given in table 7.2.

It is recommended that for structural and reinforcing steel, (P) and (α) should both be 0.95 and that for concrete, (P) and (α) should both be 0.90.

b. Estimating characteristic strength of a group of reinforcing bars

This methodology is based on the principle that the average strength of a group of bars has a lower standard deviation than the strength of an individual bar. It may be suitable for reinforcing bars functioning as a group, such as tensile reinforcement located within a reinforced concrete beam. It is reliant upon a small amount of ductility within the reinforcement, as individual bars may reach yield strength prior to the characteristic strength of the group of bars being reached.

$$f_{group} = \bar{X} - \frac{ks}{\sqrt{N}}$$

Where:

f_{group} = the characteristic yield strength (stress) of the group (MPa)

\bar{X} = the mean yield strength (stress) of a series of tests (MPa)

k = a one-sided tolerance limit factor

s = the sample standard deviation of yield strength from the series of tests

N = the number of bars functioning as a group (ie in tension) at the location of the member being assessed

Values of k for various values of (P), (α) and (n) the number of test results, are given in table 7.2. The values of (P) and (α) shall be in accordance with method (a).

This approach may not be suitable for shear reinforcement where the number of individual bars contributing to shear resistance at a section is likely to be small, and the assumption of independence of the reinforcing bars may not be appropriate.

The application of this approach to specific strength evaluations requires the professional judgement of a suitably experienced structural engineer, and must be considered on a case-by-case basis. In applying this approach the engineer shall be satisfied that tests have been taken at sufficient locations to represent the member being evaluated, or the entire group of similar members, as appropriate, including making due allowance for any anomalies in the test results and any significant variations between different members. Where these conditions cannot be satisfied, method (a) shall be used.

The background to this approach is provided in C7.3.6 in the *Bridge manual commentary*.

Table 7.2: One-sided tolerance limit factors for a normal distribution

Values of k for $\alpha = 0.90$					Values of k for $\alpha = 0.95$				
$n \backslash P$	0.900	0.950	0.990	0.999	$n \backslash P$	0.900	0.950	0.990	0.999
2	10.253	13.090	18.500	24.582	2	20.581	26.260	37.094	49.276
3	4.258	5.310	7.340	9.651	3	6.156	7.655	10.552	13.857
4	3.187	3.957	5.437	7.128	4	4.163	5.145	7.042	9.215
5	2.742	3.400	4.666	6.112	5	3.407	4.202	5.741	7.501
6	2.494	3.091	4.242	5.556	6	3.006	3.707	5.062	6.612
7	2.333	2.894	3.972	5.201	7	2.755	3.399	4.641	6.061
8	2.219	2.755	3.783	4.955	8	2.582	3.188	4.353	5.686
9	2.133	2.649	3.641	4.772	9	2.454	3.031	4.143	5.414
10	2.065	2.568	3.532	4.629	10	2.355	2.911	3.981	5.203
11	2.012	2.503	3.444	4.515	11	2.275	2.815	3.852	5.036
12	1.966	2.448	3.371	4.420	12	2.210	2.736	3.747	4.900
13	1.928	2.403	3.310	4.341	13	2.155	2.670	3.659	4.787
14	1.895	2.363	3.257	4.274	14	2.108	2.614	3.585	4.690
15	1.866	2.329	3.212	4.215	15	2.068	2.566	3.520	4.607
16	1.842	2.299	3.172	4.164	16	2.032	2.523	3.463	4.534
17	1.820	2.272	3.136	4.118	17	2.001	2.486	3.415	4.471
18	1.800	2.249	3.106	4.078	18	1.974	2.453	3.370	4.415
19	1.781	2.228	3.078	4.041	19	1.949	2.423	3.331	4.364
20	1.765	2.208	3.052	4.009	20	1.926	2.396	3.295	4.319
21	1.750	2.190	3.028	3.979	21	1.905	2.371	3.262	4.276
22	1.736	2.174	3.007	3.952	22	1.887	2.350	3.233	4.238
23	1.724	2.159	2.987	3.927	23	1.869	2.329	3.206	4.204
24	1.712	2.145	2.969	3.904	24	1.853	2.309	3.181	4.171
25	1.702	2.132	2.952	3.882	25	1.838	2.292	3.158	4.143
30	1.657	2.080	2.884	3.794	30	1.778	2.220	3.064	4.022
35	1.623	2.041	2.833	3.730	35	1.732	2.166	2.994	3.934
40	1.598	2.010	2.793	3.679	40	1.697	2.126	2.941	3.866
45	1.577	1.986	2.762	3.638	45	1.669	2.092	2.897	3.811
50	1.560	1.965	2.735	3.604	50	1.646	2.065	2.863	3.766

Adapted from *Tables for one-sided statistical tolerance limits*⁽¹⁷⁾.

7.4 Main member capacity and evaluation

7.4.1 General

The bridge overload and/or live load capacity shall be determined in terms of the net unfactored service load at the critical section of any member or group of identical members which could be critical under any live loading. The capacity of a member may be in any terms, ie moment, shear, torsion, direct force, bearing or an interaction relationship between any of these.

Assumptions which may be made about the behaviour of specific structures in defined circumstances are set out in 7.4.5.

7.4.2 Section capacity

The gross section capacity shall be calculated using the criteria specified in 4.2 to 4.6 for design.

Where conventional analysis fails to demonstrate adequate shear capacity the use of an alternative less conservative method permitted by clause 7.5.9 of NZS 3101.1&2 *Concrete structures standard*⁽¹⁸⁾ for the evaluation of shear capacity for concrete elements (eg utilising modified compression field theory or strut and tie analysis) may be considered. For details of the modified compression field theory approach, refer to CAN/CSA-S6 *Canadian highway bridge design code*⁽¹⁹⁾. For details of the strut and tie approach, refer to clause 7.5.9 and appendix A of NZS 3101⁽¹⁸⁾.

The NZTA research report 602 *Evaluation of shear connectors in composite bridges*⁽²⁰⁾ provides guidance on the evaluation of shear connectors in steel-concrete composite bridge superstructures.

The measured effects of corrosion or other deterioration shall be taken into account if appropriate.

From the gross section capacity shall be subtracted the dead load effect, and any other effect considered to be significant, all factored as necessary to give the overload capacity or the live load capacity as required. Load factors for rating, posting, HPMV and 50MAX evaluations at the ultimate limit state (see 7.4.2(a)) shall be taken from tables 7.3 and 7.4.

Other effects to be considered shall be those included in the following load combinations of tables 3.1 and 3.2:

For rating	For posting, HPMV and 50MAX evaluations
Combination 4	Combination 1A or 2A

a. For members for which evaluation at the ultimate limit state (ULS) is appropriate:

For rating	For posting, HPMV and 50MAX evaluations
$R_o = \frac{\phi R_i - \gamma_D(DL) - \Sigma(\gamma(Other\ Effects))}{\gamma_o}$	$R_L = \frac{\phi R_i - \gamma_D(DL) - \Sigma(\gamma(Other\ Effects))}{\gamma_L}$

- Where:
- R_o = overload capacity
 - R_L = live load capacity
 - R_i = section strength, using material strength determined from 7.3
 - ϕ = strength reduction factor from table 7.5
 - DL = dead load effect
 - γ_o = overload load factor from table 7.3

7.4.2 continued

γ_L = live load factor from table 7.3

γ_D = dead load factor from table 7.4

γ = load factor(s) on other effects, taken from table 3.2

- b. For prestressed concrete members for which evaluation at the serviceability limit state (SLS) is appropriate:

For rating	For posting, HPMV and 50MAX evaluations
$R_o = \left(\text{Gross capacity at stress } f_o \right) - (DL) - \left(\text{Other Effects} \right)$	$R_L = \left(\text{Gross capacity at stress } f_L \right) - (DL) - \left(\text{Other Effects} \right)$

or for members constructed in stages, where section properties vary between stages

$R_o = \left[f_o - \sum \left(\frac{DL_n}{Z_n} \right) - \sum \left(\frac{\text{Other Effects}}{Z_o} \right) \right] Z_F$	$R_L = \left[f_L - \sum \left(\frac{DL_n}{Z_n} \right) - \sum \left(\frac{\text{Other Effects}}{Z_o} \right) \right] Z_F$
--	--

Where:

- f_o = allowable stress appropriate to overweight vehicles
- f_L = allowable stress appropriate to conforming vehicles
- DL_n = dead load effect for construction stage n
- Z_n = section modulus applicable to stage n
- Z_o = section modulus applicable to other effects
- Z_F = section modulus in final condition

If a prestressed concrete member is found to have inadequate capacity under SLS evaluation, the bridge element should be investigated further to determine the likely implications. The requirement for any posting should then be discussed with the road controlling authority (with reference made to the ULS capacity of the bridge).

For the rating evaluation of prestressed concrete members at the serviceability limit state, the permissible stresses and stress range applicable to load combinations including traffic overload on bridges specified in NZS 3101⁽¹⁸⁾ shall not be exceeded. In section 19 of NZS 3101⁽¹⁸⁾ the terminology "frequently repetitive live loading" shall be read to be normal live loading (load type LL) and "infrequent live loading" shall be read to be overload (load type OL).

For the posting, HPMV and 50MAX evaluation of prestressed concrete members at the serviceability limit state, the following criteria shall apply:

- The vehicle load effect shall be taken as that due to 1.35 x load x I (see 7.4.6).
- The permissible stress in compression in concrete due to service loads or normal live load for bridges, specified by NZS 3101⁽¹⁸⁾ shall not be exceeded. This permissible stress may however be increased by 20% for load combinations excluding differential temperature, where a higher permissible stress is already permitted.
- The permissible extreme fibre tensile stresses under service loads specified in NZS 3101⁽¹⁸⁾ shall not be exceeded. Where treated as Class U or T members and the tensile stress is the limiting criterion, the member may be assessed as a cracked (Class C) member.
- The permissible stress range in prestressed and non-prestressed reinforcement due to frequently repetitive live loading specified by NZS 3101⁽¹⁸⁾ may be increased by 20%.
- The maximum allowable crack width specified by 4.2.1(a) assessed in accordance with NZS 3101⁽¹⁸⁾ shall not be exceeded.

7.4.2 continued

For the posting, HPMV and 50MAX evaluation of prestressed concrete bridges satisfying the criteria for adoption of higher stress levels in 7.4.3, with members assessed at the serviceability limit state in accordance with 7.4.2(b), the following criteria apply:

- The vehicle load effect shall be taken as that due to $1.35 \times \text{load} \times I$ (see 7.4.6).
- Where compression in the concrete is the limiting criterion, f_L , the allowable stress in the member, may be taken as 30% greater than the permissible stress in compression of concrete under normal live load for bridges specified by NZS 3101⁽¹⁸⁾ for load combinations excluding differential temperature, and 10% greater for load combinations including differential temperature.
- The permissible stress range in prestressed and non-prestressed reinforcement due to frequently repetitive live loading specified by NZS 3101⁽¹⁸⁾ may be increased by 30%.

Table 7.3: Rating, posting and HPMV evaluation live load ULS load factors*

Rating loads	γ_o	1.49
Posting loads HPMV and 50MAX evaluation loads	γ_L	1.90 or 1.75**

* In no case shall the load factor on the total of all gravity load effects be less than 1.25.

** 1.75 may be adopted only when the conditions for adopting higher stress levels, as set out in 7.4.3, are satisfied.

Table 7.4: Dead load ULS load factors (γ_D)*

Wearing surface, nominal thickness	1.40
In situ concrete, nominal sizes Wearing surface, measured thickness	1.20
In situ concrete, measured dimensions and verified density Factory precast concrete, verified density Structural steel	1.10

* In no case shall the load factor on the total of all gravity load effects be less than 1.25.

Table 7.5: Strength reduction factors (ϕ)

Superstructure condition	Critical section properties based on:	
	construction drawings and assessed sound material	measured dimensions or verified as-built drawings, and measured sound material
Elastic analysis method		
Good or fair	$1.00\phi_D$	$1.00\phi_D$
Deteriorated	$0.80\phi_D$	$0.90\phi_D$
Seriously deteriorated	$0.70\phi_D$	$0.80\phi_D$

Where ϕ_D is the applicable strength reduction factor given by the materials design standard, or for timber given by 4.4.2.

7.4.3 Higher allowable stress levels for general access posting and HPMV and 50MAX evaluations

In the evaluation of bridges for posting when subjected to general access vehicle loading, or for their capacity to sustain HPMV and 50MAX conforming vehicle loading, higher stress levels (ie lower load factors) may be justified where only a small number of bridges are restrictive on an important route. For this approach to be adopted, all of the following criteria shall be met:

- i. The bridge must be one of a small number of bridges restricting vehicles on an important route.
- ii. The deterioration factors for the bridge shall be accurately assessed. This shall be confirmed by undertaking an initial inspection to assess the condition of the bridge.
- iii. The engineer shall be satisfied that the structure has a ductile failure mode.
- iv. The accuracy of the bridge structural data shall be confirmed (ie shear and moment capacities and eccentricity values must be confirmed).
- v. The bridge shall be inspected at no more than six-monthly intervals to observe any structural deterioration.
- vi. The engineer shall be satisfied that early replacement or strengthening is feasible, whilst being cognisant of the extent of any disruption created if early replacement was required and the availability of any detour routes.

The decision to implement a specific inspection programme for a critical bridge to justify higher working stresses shall be discussed with the road controlling authority to ensure that the heavy motor vehicle, HPMV or 50MAX demand for a particular route justifies the cost of regular inspections. This decision is only expected to be made for bridges with a high heavy motor vehicle, HPMV or 50MAX demand, that are one of only a few critical bridges on a route, that are in good condition, and where regular inspections would be relatively easy to undertake.

7.4.4 Live loading and analysis

The bridge shall be considered to be loaded with elements of live loading at their most adverse eccentricity in load lanes defined as follows:

The number of load lanes shall generally equal the number of marked lanes on the bridge. Load lanes shall generally be demarcated by the lane markings, except that shoulders shall be combined with the adjacent marked lanes to form load lanes. Where the combined width of the shoulder and marked lane exceeds 4.5m, a loading arrangement with the edge load lane width reduced to 4.5m, with a commensurate increase in the width of the adjacent load lane, shall also be considered.

For single lane or un-marked bridges, the number of load lanes shall not be less than that determined in accordance with 3.2.3(b), and they shall be of equal width.

Dynamic load factors shall be included, as described in 7.2.2. Reduction factors as specified in 3.2.4 shall be applied to each combination of vehicle loads.

- a. A bridge with one load lane shall be loaded as follows:

For rating	For posting	For HPMV evaluation	For 50MAX evaluation
0.85HO	0.85HN	Up to 25m loaded length 0.90HN	Up to 25m loaded length 0.85HN
		Greater than 25m loaded length 0.95HN	Greater than 25m loaded length 0.90HN

7.4.4 continued

b. A bridge with two or more load lanes shall normally be loaded as follows:

For rating	For posting	For HPMV evaluation	For 50MAX evaluation
Up to 25m loaded length 0.85HO in the most adverse lane, together with 0.90HN in some or all other marked lanes, where critical	0.85HN in some or all marked lanes	Up to 25m loaded length 0.90HN in some or all marked lanes	Up to 25m loaded length 0.85HN in some or all marked lanes
Greater than 25m loaded length 0.85HO in the most adverse lane, together with 0.95HN in some or all other marked lanes, where critical		Greater than 25m loaded length 0.95HN in some or all marked lanes	Greater than 25m loaded length 0.90HN in some or all marked lanes

For all evaluations, if the case of one lane loaded is more critical, this configuration shall be used.

For loadings in (a) and (b) the loaded length shall be defined as follows:

- i. For positive bending moments and end shear, the loaded length is the span length in which the bending moment or shear force is being considered.
- ii. For negative moment over interior supports, the loaded length is the average of the adjacent spans.
- iii. For reactions, the loaded length is the sum of the adjacent spans.
- iv. For transoms, the loaded length is twice the longitudinal spacing of the transoms.

The above definitions shall not apply to 3.2.5 or figure 3.2.

The bridge shall be analysed assuming elastic behaviour to determine the effects of the above loads at the critical locations for which capacities have been determined. Analysis shall take into consideration the relative stiffnesses of the various members, and their end conditions. Stiffness values for reinforced concrete members shall allow for the effects of cracking.

7.4.5 Assumptions for specific structural situations

a. Over-reinforced concrete sections

The intent of clause 9.3.8.1 of NZS 3101⁽¹⁸⁾ shall be complied with. The capacity of a reinforced concrete section shall not be taken as more than that derived using the area of tension steel which would correspond to a distance from the extreme compression fibre to the neutral axis of $0.75C_b$.

C_b is the distance from extreme compression fibre to neutral axis at balanced strain conditions, as defined in clause 7.4.2.8 of NZS 3101⁽¹⁸⁾.

b. Concrete kerbs cast onto a composite deck

Where a kerb has been cast directly onto the deck over its full length and has at least a nominal amount of reinforcing steel connecting it to the deck, and is within the effective flange width of the beam, the moment capacity of the outer beam may be calculated assuming that the kerb is an integral part of it, with the following provisos:

- i. The area of concrete in the kerb shall be assumed to be 50% of its actual area, to allow for shear lag effects, unless tests indicate otherwise.
- ii. The neutral axis shall not be taken to be above the level of the deck surface.

7.4.5 continued

c. Concrete handrails

No reliance shall be placed on the contribution to longitudinal bending capacity of beams by concrete handrails.

d. Steel beams with non-composite concrete deck

No account shall be taken of such a non-composite deck in determining the bending capacity of the beams, except insofar as it may stiffen the beam top flanges, and thus increase their buckling load. Friction shall not be considered to contribute to composite action, nor to the stiffening of top flanges. Note however that the NZTA research report 602⁽²⁰⁾ provides evaluation procedures for partially composite bridges.

e. Steel beams with timber deck

Effective lateral support of the beam flanges by the deck shall only be assumed if the timber deck fastenings are adequate in number and condition.

f. Continuous or framed-in beams

For beams with full moment continuity between spans, of normal proportions and showing no signs of distress, the following simplified procedure may be followed:

The overall moment capacity of each span may be converted to that of an equivalent simple span by subtracting (algebraically) the midspan positive moment capacity from the mean of the two negative moment capacities at its supports. This will give the overall ordinate of the moment of resistance diagram, and both dead and live load moments may then be calculated as though it were a simple span. This procedure shall not be followed for a short span whose length is less than 60% of an adjacent long span, nor for live load effect on a span adjacent to a free cantilever span. The possibility of uplift at an adjacent support shall be considered.

g. Spans built into abutments

Reinforced concrete T-beam spans built monolithically with their abutments may be considered for treatment as in (f), with the following provisos:

- i. If negative moment yield at abutments can be shown to occur at a load greater than 85% of that at which midspan positive moment yield occurs, the working load capacity may be based on the full yield capacity of the section at all locations.
- ii. If negative moment yield at abutments occurs at a lesser load than 85% of that at which midspan positive moment yield occurs:
 - o either the net unfactored service load capacity may be based on the full yield capacity at the abutments, with a reduced yield capacity at midspan, corresponding to the actual moment when abutment yield occurs, or
 - o the net unfactored service load capacity may be calculated assuming zero abutment moment capacity.

In any case, where negative moment capacity is to be relied on, the ability of the abutments to resist the overall negative moments without excessive displacement, either by foundation reaction or by earth pressure, or both shall be assured.

h. Horizontal support restraint

Where the bearings and supports of a beam possess sufficient strength and stiffness horizontally, the horizontal support reaction to live loading may be taken into account where appropriate.

7.4.5 continued

- i. Longitudinal shear capacity at construction joints in reinforced concrete T-beam bridges

The longitudinal shear capacity at deck/beam construction joints on reinforced concrete T-beam bridges should be reviewed, where there is evidence of joint cracking or movement. Poor construction joint quality affecting composite action has been found on various bridges due to contamination with construction debris, a lack of concrete surface preparation, or minimal shear reinforcement across the construction joint.

For all concrete T-beam bridges subject to capacity assessment, a thorough inspection should be undertaken to identify possible non-composite action at the construction joint.

The assessment of longitudinal shear capacity shall be in accordance with clause 7.7 of NZS 3101⁽¹⁸⁾. Allowance should be made for the effect of any construction defects, in particular on the friction coefficient. The effect of reduced composite action on other capacities (eg vertical shear and flexure) shall be evaluated.

7.4.6 Rating, posting, HPMV and 50MAX evaluations

For each critical location in the bridge the rating, posting, HPMV and 50MAX evaluations shall be calculated as described below. In each of the calculations the denominator shall include the effects of eccentricity of load and of dynamic load factors. R_o and R_L are the section capacities calculated as 7.4.2.

If data is to be entered into OPermit, the CLASS calculation is not necessary (see 7.4.7).

For rating	For posting
$CLASS = \left[\frac{R_o \times 100}{\text{Rating load effect}} \right]_{\min} \%$ <p>The minimum value for any member in the bridge, except the deck, shall be recorded in a structural inventory as the CLASS for manual calculations during processing of overweight permits in accordance with the <i>Overweight permit manual</i>⁽³⁾. For this purpose, any value of CLASS more than 120% shall be recorded as 120%.</p>	$GROSS = \left[\frac{R_L \times 100}{\text{Posting load effect}} \right]_{\min} \%$ <p>The minimum value for any member in the bridge, except the deck, shall be rounded to the nearest 10%. If this value is less than 100%, it shall be recorded after the word GROSS in panel 2 of the heavy motor vehicle bridge limit sign, shown in diagram R5-9 of part 3, schedule 1 of the Land Transport Rule: Traffic Control Devices 2004⁽²¹⁾ (ie as a % of Class I loading).</p> <p>If the speed is restricted by inserting a value in panel 3 of the sign, the dynamic load factor may be reduced in accordance with 7.2.2.</p>

For HPMV and 50MAX evaluations

Evaluations for HPMV and 50MAX loading shall follow the same procedure as for posting with HPMV or 50MAX evaluation load effects as applicable replacing posting load effect in the GROSS equation. If the value of GROSS is less than 100% then the bridge is unable to carry HPMV loading or 50MAX loading. A reduced dynamic load factor may be used in accordance with 7.2.2.

7.4.7 Highway permits data

For all state highway bridges, major culverts, stock underpasses and subways and some local authority structures including bypass routes, the basic rating data described above is stored in OPermit. A description of the form in which the data is required and the calculations which the program performs is contained in *OPermit bridge structural data guide*⁽⁴⁾.

7.5 Deck capacity and evaluation

7.5.1 General

Evaluation procedures for the following are given in this clause:

- Reinforced concrete decks by empirical design, based on assumed membrane action.
- Reinforced concrete decks by the simplified evaluation method.
- Reinforced concrete decks by elastic plate bending analysis.
- Timber decks.

A reinforced concrete deck panel may be evaluated against the criteria for the empirical design of concrete decks based on membrane action as per 7.5.2.

Otherwise generally, a reinforced concrete deck panel which is supported on four sides should be evaluated by the simplified evaluation method if it meets the criteria listed in 7.5.3(a). All remaining reinforced concrete deck panels should be evaluated by the elastic plate bending analysis method. In addition, reinforced concrete deck slabs shall be evaluated for their punching shear capacity for wheel loads, taking into account deterioration of the bridge deck using the factors in table 7.5.

It shall be assumed that vehicle wheels can be transversely positioned anywhere between the kerbs or guardrails, but generally no closer than the restriction imposed by the 3m wide load lane of HN loading (figure 3.1). Ordinarily, any vehicle wheel loads positioned outside the restriction imposed by the 3m wide load lane of HN loading, such as a wheel located at the outer edge of a carriageway against a kerb, shall be treated as a load combination 4 (overload), using loads in tables 7.7 and 7.8. For narrow bridges where wheel loads will frequently be positioned closer to the kerb or guardrail than represented in figure 3.1, evaluation of load combination 1 (normal traffic) shall be carried out based on the expected range of wheel positions of normal traffic for the specific structure geometry.

7.5.2 Reinforced concrete decks: empirical design based on assumed membrane action

Where the requirements for empirical design based on assumed membrane action in accordance with NZS 3101⁽¹⁸⁾ clause 12.8.2 are satisfied, the deck slab shall be considered to have adequate resistance to HN-HO-72 loading.

7.5.3 Reinforced concrete decks: simplified evaluation method

a. Criteria for determining applicability of the simplified evaluation method

The simplified evaluation method takes account of membrane action in the slab, and is based on test results. Evaluation of both composite* and non-composite reinforced concrete deck slab panels may be determined by this method provided the following conditions are satisfied:

- The slab panel shall be supported on all sides by steel or concrete beams, girders or diaphragms.
- Cross-frames or diaphragms shall be continuous between external beams or girders, and the maximum spacing of such cross-frames or diaphragms shall be as follows:
 - o Steel I beams and box girders of steel or concrete: 8.0m.
 - o Reinforced and prestressed concrete beams: at supports.

* For the purposes of this clause, any steel beam and concrete deck bridge designed compositely (but not necessarily meeting current composite design requirements), or any concrete beams cast monolithically and interconnected with reinforcement with a concrete deck, shall be considered to be composite.

7.5.3 continued

- The ratio of span length (L_s) to minimum slab thickness shall not exceed 20. In skew slabs where the reinforcing has been placed parallel with the skew, the skew span, $L_s/\cos Y$ shall be used, where Y = angle of skew.
- The span length (L_s) or $L_s/\cos Y$ shall not exceed 4.5m.
- The concrete compressive strength shall not be less than 20MPa.
- The slab thickness, or for slabs of variable thickness the minimum slab thickness, shall be not less than 150mm.
- There shall be an overhang beyond the centre line of the outside beam of at least 0.80m measured perpendicular to the beam. The overhang shall be of the minimum slab thickness used to determine the span to thickness ratio above. This condition may be considered satisfied if there is an integral continuous concrete kerb or barrier which provides a combined cross-sectional area of slab and kerb or barrier not less than the cross-sectional area of 0.80m of deck slab.

b. Deck strength in terms of wheel load

For rating (HO wheel contact area alternative (b) of figure 3.1 assumed), the unfactored ultimate resistance (R_i) of a composite or non-composite deck slab shall be calculated as follows:

$$R_i = R_d F_q F_c$$

Where R_d is taken from figure 7.1 or 7.2, as applicable, for the deck thickness (d) and the deck span being considered; F_q is a correction factor based on the value of reinforcement percentage (q) where q is the average of the lower layer reinforcement percentages at the midspan of the slab, in the two directions in which the reinforcement is placed; and F_c is a correction factor based on the concrete strength (f_c').

The values of F_q and F_c shall be taken from figure 7.1 or 7.2, as applicable, or obtained from those figures by linear interpolation.

For deck thicknesses other than those shown in figures 7.1 and 7.2, the value of R_i shall be obtained by linear interpolation.

For posting, HPMV and 50MAX evaluations (HN wheel contact area assumed) the value of R_i obtained shall be multiplied by 0.6.

The dead load and other load effects are ignored in this method.

The "design" strength reduction factor (ϕ_D) for the simplified evaluation method is 0.5. The strength reduction factor (ϕ) used for evaluation shall be taken from table 7.6, by multiplying ϕ_D by the appropriate factor. In this table, deck deterioration is quantified by the crack-to-reinforcing ratio (CRR) defined as follows:

$$\text{CRR} = \frac{\text{Total length of visible cracks}}{\text{Total length of bottom reinforcement in both directions}} \times 100$$

The above lengths shall be measured in a 1.2m square area on the bottom of the slab, central between supports.

c. Rating and posting evaluations

For each type of slab panel in the bridge, the parameters shall be calculated as follows. Rating and posting wheel loads shall be taken from tables 7.7 and 7.8. Dynamic load factor (I) shall be as described in 7.2.2. γ_o and γ_L shall be taken from table 7.3.

7.5.3 continued

For rating	For posting
Deck capacity factor (DCF) $= \left[\frac{\text{Overload wheel load capacity}}{\text{Rating load effect}} \right]_{\min}$ $= \left[\frac{\phi R_i}{\gamma_o \times 95 \times I} \right]_{\min}$	Allowable axle load (kg) $= \left[\frac{\text{Liveload wheel load capacity}}{\text{Posting load effect}} \times 8200 \right]_{\min}$ $= \left[\frac{\phi \times (0.6R_i)}{\gamma_L \times 40 \times I} \times 8200 \right]_{\min}$

d. HPMV and 50MAX evaluations

Evaluations for HPMV and 50MAX loading shall follow the same procedure as for posting. If the allowable axle load determined is less than 8800kg for HPMV or 8200kg for 50MAX then the bridge is unable to carry HPMV or 50MAX loading as applicable.

Table 7.6: Strength reduction factors (ϕ) for slabs evaluated by the simplified evaluation method

Superstructure condition	Slab section properties based on:	
	construction drawings and assessed sound material	measured dimensions or verified as-built drawings, and measured sound material
Good or fair (CRR \leq 40%)	$0.90\phi_D$	$1.00\phi_D$
Deteriorated (CRR = 70%)	$0.60\phi_D$	$0.70\phi_D$
Seriously deteriorated (CRR = 100%)	$0.30\phi_D$	$0.40\phi_D$

Table 7.7: Deck rating loads

Axle type	Axle load (kN)	Wheel track and contact area
Twin-tyred	105	As for HN axle
Single-tyred, large tyres	190*	As for HO axle, alternative (b)
2/8-tyred oscillating axles, spaced 1.0m	133	As for HO axle, alternative (a)

Table 7.8: Deck posting, HPMV and 50MAX evaluation loads

Axle type	Axle load (kN)	Wheel track and contact area
Posting (general access) and 50MAX		
Twin-tyred	80*	As for HN axle
Four-tyred oscillating	93	4/250 x 150mm areas equally spaced within 2500mm overall width
2/Twin-tyred axles, spaced 1.0m	71	As for HN axle
HPMV		
Twin-tyred	86*	As for HN axle
Four-tyred oscillating	93	4/250 x 150mm areas equally spaced within 2500mm overall width
2/Twin-tyred axles, spaced 1.0m	74	As for HN axle

* Wheel loads from these axles are used for evaluation by the simplified evaluation method in 7.5.3(c).

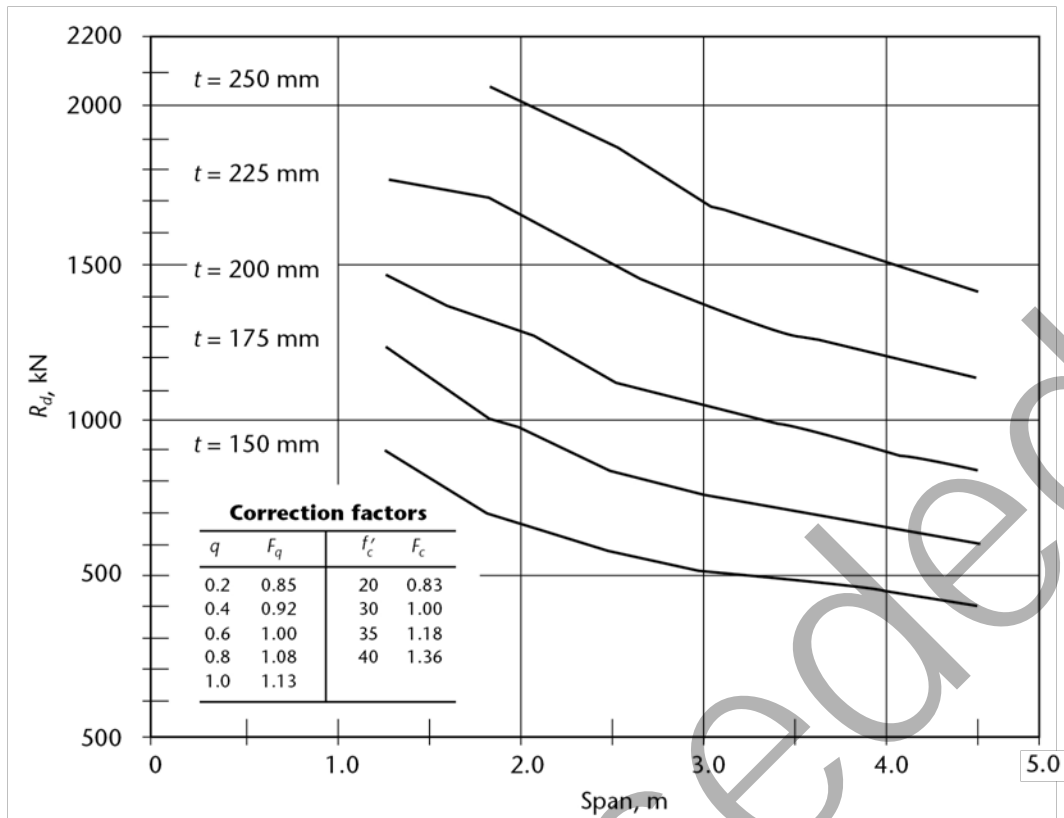
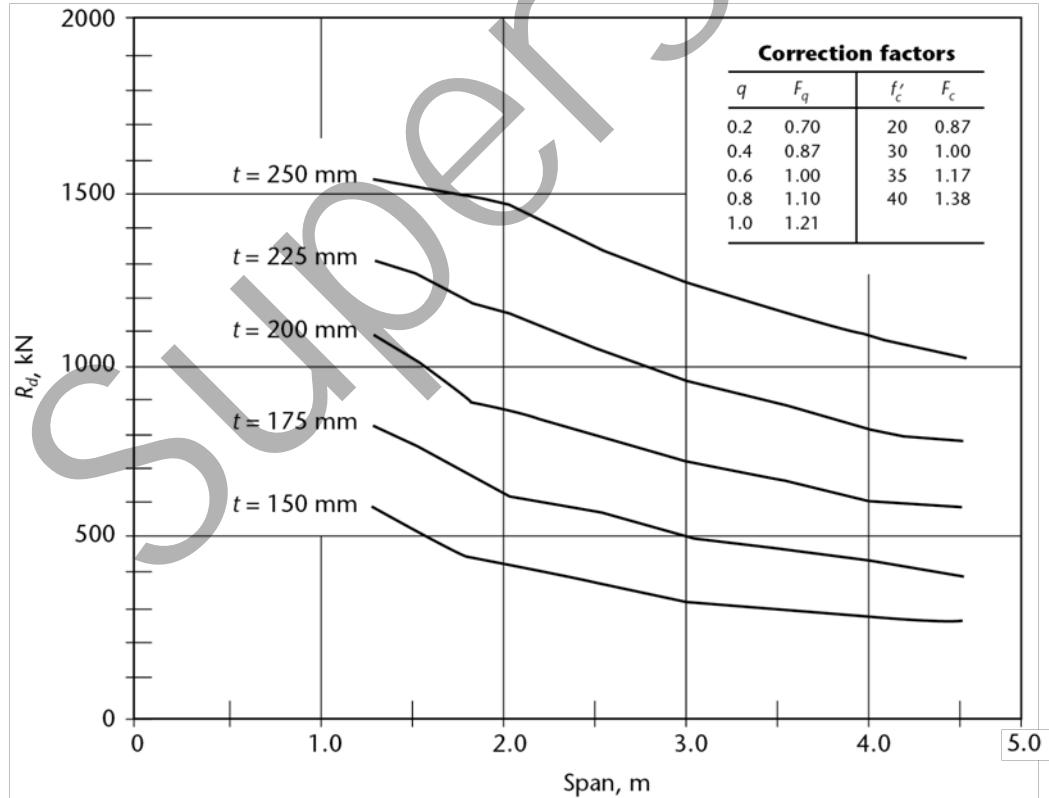
Figure 7.1: R_d (kN) for composite concrete deck slabsFigure 7.2: R_d (kN) for non-composite concrete deck slabs

Figures 7.1 and 7.2 and selected text in 7.5.3(b) are reproduced with the permission of Canadian Standards Association (CSA) from CAN/CSA-S6-06 *Canadian Highway Bridge Design Code*⁽¹⁹⁾ which is copyrighted by CSA, 5060 Spectrum Way, Mississauga ON, L4W 5N6 Canada. This reprinted material is not the complete and official position of CSA on the reference subject, which is represented solely by the standard in its entirety. For more information on CSA or to purchase standards, please visit their website at www.shop.csa.ca.

7.5.4 Reinforced concrete decks: plate bending analysis

a. Section capacity at critical locations

The deck slab live load or overload flexural capacity shall be determined using the methodology described in 7.4.2(a), in moment per unit width at critical locations in the slab. A simplification may be made in the case of a slab which is considered to act as a one-way slab, that is, if it has an aspect ratio of at least 4. Provided it has a positive moment capacity in the long-span direction at least 50% of that in the short-span direction, all moment capacities in the long-span direction may be ignored.

b. Live loading and analysis

For rating	For posting, HPMV and 50MAX evaluations
The deck shall be considered to be loaded with the most adverse of the axles or axle groups listed in the <i>Overweight permit manual</i> ⁽³⁾ , at a vehicle axle index (VAI) of 1.3. The number of loaded axles shall be limited to produce a vehicle gross index (VGI) of up to 1.75. For deck spans up to 3m, these may be reduced to the three alternatives described in table 7.7.	The deck shall be considered to be loaded with the most adverse of the axles or axle sets described in the Land Transport Rule: Vehicle Dimensions and Mass 2016 ⁽²⁾ : <ul style="list-style-type: none"> For general access and 50MAX vehicles: schedule 3, part 1, <i>Axle mass limits - General access</i>, tables 1.1 to 1.5. For HPMV vehicles: schedule 3, part 3 <i>Maximum axle mass for heavy motor vehicles operating on a HPMV or specialist vehicle permit</i>, tables 3.1 to 3.6. For deck spans up to 3m, these may be reduced to the alternatives described in table 7.8.

The slab shall be analysed for the loads given in tables 7.7 and/or 7.8 assuming elastic behaviour, and shall be assumed to act as a thin plate in which membrane action is not taken into account. The moment effects of the various loads on the critical locations shall be calculated.

c. Rating and posting evaluations

For each critical location in the slab, the evaluation shall be calculated as described below. In both calculations, the denominator shall include dynamic load factors as in 7.2.2, and the numerator shall be as described in (a). The value of DCF or axle load adopted shall be the minimum for the bridge.

For rating	For posting
<p>Deck capacity factor (DCF)</p> $= \left[\frac{\text{Overload capacity at critical location}}{\text{Rating load effect}} \right]_{\min}$ <p>The minimum value for the bridge shall be recorded as the DCF for the bridge.</p>	<p>Allowable axle load (kg)</p> $= \left[\frac{\text{Liveload capacity at critical location}}{\text{Posting load effect}} \times 8200 \right]_{\min}$ <p>The minimum value for the bridge shall be rounded to the nearest 500kg and if less than 8200kg, shall be recorded after the word AXLES, in panel 1 of the heavy motor vehicle bridge limit sign, shown in diagram R5-9, schedule 1 of the Land Transport Rule: Traffic Control Devices 2004⁽²¹⁾.</p>

d. HPMV and 50MAX evaluations

Evaluations for HPMV and 50MAX loading shall consider loading comprising the most adverse axles or axle sets described in (b). If this loading is greater than the deck's live load capacity at the critical location, then the bridge is unable to carry HPMV or 50MAX loading as applicable.

7.5.5 Timber decks

a. Section capacity of nominal width

It is assumed that timber decks generally consist of a plank system spanning transversely between longitudinal main beams. Other systems shall be evaluated using the principles described, varying the details to suit.

Unless data is to be entered into OPermit (see 7.4.7), the live load or overload moment capacity for timber decks consisting of planks spanning transversely between main beams shall be determined for the nominal width of section considered to carry one axle. The nominal widths given in (i) to (vi) below may be assumed unless investigations indicate other criteria. If the timber deck planks are continuous over two or more spans, the section capacity may be assumed increased by 25%, provided live load moments are calculated on a simple span basis.

Terms are defined as follows:

- **Plank width** is the larger cross-sectional dimension of a deck plank, regardless of its orientation, in metres. It is the actual dimension, not the call dimension.
- **Deck span** is the span of the planks between the centres of areas of bearing, in metres.
- **Contact length** is the dimension, perpendicular to the plank span, of a wheel contact area, and is assumed to be 0.25m.
- **Nominal width:**
 - i. For planks laid flat, without running planks at least 50mm thick, the nominal width is equal to the width of a whole number of planks, and is greater than the contact length by not more than one plank width.
 - ii. For planks laid flat, with running planks at least 50mm thick, the nominal width is equal to the width of a whole number of planks, and is greater than the contact length by not more than two plank widths.
 - iii. For nail laminated deck, with planks on edge, fabricated into baulks with no shear connection between them, the nominal width is:
 $0.250\text{m} + 0.4 \times (\text{Plank width}) \times (\text{Deck span})$.
 - iv. For nail-laminated deck, with planks on edge, end laminations well supported and:
 - o fabricated in baulks with shear connection between them by steel dowels or other means, or
 - o fabricated in baulks and having running planks over them more than 50mm thick, or
 - o fabricated in situ, continuously across the beam span, with no unconnected joints between laminations, the nominal width is:
 $0.250\text{m} + 0.8 \times (\text{Plank width}) \times (\text{Deck span})$.
 - v. For glue-laminated deck, with planks on edge, fabricated in baulks with no shear connection between them, the nominal width is:
 $0.250\text{m} + 1.5 \times (\text{Plank width}) \times (\text{Deck span})$.
 - vi. For glue-laminated deck, with planks on edge, otherwise as for (iv), the nominal width is: $0.250\text{m} + 3.0 \times (\text{Plank width}) \times (\text{Deck span})$.

Dead load may be neglected in the above calculation.

b. Live loading and analysis

The transverse moments due to the various axles described in tables 7.7 and/or 7.8 on the span between beams shall be calculated assuming the deck planks are simply supported.

7.5.5 continued

c. Rating and posting evaluations

For the nominal width at the midspan section of a timber deck span, the evaluation shall be calculated as described below. In both calculations, the numerator shall be as described in (a).

The value of DCF or axial load adopted shall be the minimum for the bridge.

For rating	For posting
<p>Deck capacity factor (DCF)</p> $= \left[\frac{\text{Overload capacity of nominal width}}{\text{Rating load effect}} \right]_{\min}$ <p>The minimum value for the bridge shall be recorded as the DCF for the bridge.</p>	<p>Allowable axle load (kg)</p> $= \left[\frac{\text{Liveload capacity of nominal width}}{\text{Posting load effect}} \times 8200 \right]_{\min}$ <p>The minimum value for the bridge shall be rounded to the nearest 500kg, and if less than 8200kg, shall be recorded after the word AXLES, in panel 1 of the heavy motor vehicle bridge limit sign, shown in diagram R5-9, schedule 1 of the Land Transport Rule: Traffic Control Devices 2004⁽²¹⁾.</p>

d. HPMV and 50MAX evaluations

Evaluations for HPMV and 50MAX loading shall consider live loading described in (b). If this loading is greater than the deck's live load capacity for the nominal width of deck under consideration, then the bridge is unable to carry HPMV or 50MAX loading as applicable.

7.5.6 Deck grade

In 7.5.3(c), 7.5.4(c) and 7.5.5(c) the rating calculation has produced a DCF. For issue of permits by the manual method, the DCF shall be converted to a grade, using the relationship given in table 7.9.

Table 7.9: Relationship between DCF and grade

		Grade
	DCF ≥ 1.00	A
1.00	> DCF ≥ 0.89	B
0.89	> DCF ≥ 0.78	C
0.78	> DCF ≥ 0.67	D
0.67	> DCF ≥	E

7.5.7 Highway permits data

The statement in 7.4.7 applies but, for decks, only the DCF is required.

7.6 Proof loading

Proof loading may be undertaken in addition to the procedure described in 7.1 to 7.5, either to verify the theoretical findings and assumptions made, or to extend the load limits where the results of the procedure are considered to be not representative of the structure's actual behaviour.

Proof loading shall not be relied on to determine load limits for bridges with features such as those described in 7.6.2(a)(iv) and (v), without either modifying the structure, or multiplying the load factors of 7.4.2 by 1.5.

7.6.1 Preliminary

a. Objective

The objective of proof loading shall be to determine experimentally the safe load limit for either overweight loads or normal loads or both, expressed as defined in 7.4.6, 7.5.3(c), 7.5.4(c) and 7.5.5(c).

b. Scope

These requirements apply to main member spans of all materials up to 30m, and to decks. Proof loading of spans larger than 30m may require additional criteria.

c. Analysis

Before testing of any bridge, adequate analysis shall be performed to determine its likely behaviour, including its failure mode.

d. Personnel

Personnel engaged in proof loading shall be experienced and competent, in order to minimise the risk associated with loading beyond the linear range.

e. Risk

The risk of failure or damage being induced by testing shall be clearly stated to the controlling authority.

7.6.2 Analysis

a. Objectives

The objectives of the analysis shall be:

- i. To model the structural behaviour up to yield level.
- ii. To assess the amount of redundancy in the structural system and its implications for behaviour.
- iii. To determine if the bridge failure mode is likely to be ductile or not.
- iv. To identify and evaluate features which would give an apparent enhancement of strength up to proof-load level but which could be followed by sudden failure. Such features may include a non-composite deck as described in 7.4.5(d).
- v. To identify and evaluate features which are likely to affect the distribution of loads differently at proof load level and at yield load level, such as a stiff concrete handrail, as described in 7.4.5(c).

b. Evaluation of main members

The bridge shall be analysed for the rating and/or posting load as described in 7.4.4, to determine the load effects at the critical location. It shall also be analysed for the actual test loading configuration proposed to be used. This shall be chosen so that it will produce approximately the same relative effects on critical members as the evaluation loading described in 7.4.4. If there is more than one critical effect to be monitored, the load may need to be applied in more than one place, eg to induce both maximum moment and shear in a beam.

c. Evaluation of decks

Sufficient analysis shall be carried out to determine which of the axle configurations in tables 7.7 or 7.8 is most critical, and the critical load position(s). The likely failure mode(s) shall be determined.

7.6.3 Load application, instrumentation and procedure

- a. The nature and magnitude of the proof load, and/or any prior modification of the structure, shall be consistent with the objectives of 7.6.2(a).
- b. For evaluation of main members lanes shall be loaded to represent the effects of the evaluation loads described in 7.4.4, including dynamic load factors as in 7.2.2.
For evaluation of decks, contact areas corresponding to the most critical of the axle loads of tables 7.7 or 7.8 shall be loaded, to represent the evaluation load including dynamic load factors.
- c. If the failure mode is likely to be non-ductile or there is little redundancy in the structure, a jacking system shall be used to apply the load in preference to gravity because of the added control it gives against inadvertent failure.
- d. Appropriate strains, deflections and crack widths shall be recorded and correlated with the applied load. Care shall be taken to eliminate errors due to thermal movement. A plot of critical effect(s) against load shall be monitored to ensure that the limits set in 7.6.4 are not exceeded. The test load shall be applied in approximately equal increments, at least four of which shall lie on the anticipated linear part of the response curve. Critical effects shall be recorded in a consistent manner, immediately after the application of each load increment.
- e. During incremental loading, the next increment of load shall not be applied until displacement under the previous increment of load has stabilised. Following application of the final increment of load the total proof load shall be applied for not less than fifteen minutes after the displacement has stabilised.

7.6.4 Load limit criteria

- a. Main members
Loading shall not exceed either:
 - i. the load which, together with dead load effects, produces 80% of the yield load on the critical member, as determined by the analysis of 7.6.2, or
 - ii. that at which the response of the critical member deflection exceeds the value which would be predicted by linear extrapolation of the initial part of the load/response curve by the following percentage.

Member material	Percentage offset
Structural steel	10
Prestressed concrete	15
Reinforced concrete, composite steel/concrete	20
Timber	25

- b. Decks
Loading shall not exceed either:
 - i. 80% of the load (on the same contact area) calculated to produce yield in the deck, or
 - ii. that at which the deck local deflection exceeds a value determined as in (a)(ii) above.

7.6.4 continued

c. Concrete cracking criteria

Under proof loading to establish the safe load limit for normal loads, at the maximum load, critical crack widths of reinforced concrete and prestressed concrete shall be recorded. Also under proof loading to establish the safe load limit for overloads, the crack widths under a level of loading equivalent to normal live load shall be recorded. If such cracks are wider than allowed under 4.2.1(a), then regular inspection shall be instituted, specifically to detect any ongoing deterioration of the cracking and possible corrosion.

7.6.5 Rating, posting, HPMV and 50MAX evaluations

a. Correlation of analysis and test results

The results of testing shall be compared with predicted results from the analysis of 7.6.2. The reasons for major differences between predicted and actual behaviour shall be resolved before adoption of rating or posting parameters based on tests.

b. Main members

Rating and posting parameters shall be calculated as in 7.4.6. In the calculations R_i shall be the calculated effect at the critical location of the maximum applied test load divided by $(0.8 \times \gamma_L)$. R_o shall be the same value divided by $(0.8 \times \gamma_o)$.

Rating, posting, HPMV and 50MAX load effects shall be taken from the analysis of 7.6.2 and shall include dynamic load factors.

c. Decks

Parameters shall be calculated as follows:

For rating	For posting and 50MAX
DCF	Allowable axle load (kg)
$= \left[\frac{T_o}{0.8 \times \gamma_o \times (\text{Rating load}) \times I} \right]$	$= \left[\frac{T_L \times 8200}{0.8 \times \gamma_L \times (\text{Posting load}) \times I} \right]$
	For HPMV
	Allowable axle load (kg)
	$= \left[\frac{T_L \times 8800}{0.8 \times \gamma_L \times (\text{HPMV load}) \times I} \right]$

Where T_o and T_L are the maximum applied wheel or axle loads obtained from the proof loading, applied on the contact areas specified in tables 7.7 and 7.8 respectively. Rating, posting, HPMV and 50MAX loads are the appropriate wheel or axle loads from tables 7.7 and 7.8.

For HPMV and 50MAX, if the allowable axle load determined is less than 8800kg or 8200kg respectively then the bridge is unable to carry HPMV or 50MAX loading as applicable.

7.7 References

- (1) Ministry of Transport (1974) Heavy Motor Vehicle Regulations 1974. Wellington.
- (2) Ministry of Transport (2016) Land Transport Rule: Vehicle Dimensions and Mass 2016. Wellington.
- (3) NZ Transport Agency (1995) *Overweight permit manual (SM070)*. Wellington.
- (4) NZ Transport Agency (2016) *OPermit bridge structural data guide*. Wellington.
- (5) Standards New Zealand NZS 3112.2:1986 *Methods of test for concrete*. Part 2 Tests relating to the determination of strength of concrete.
- (6) British Standards Institution BS EN ISO 6892-1:2016 *Metallic materials. Tensile testing*. Part 1 Method of test at room temperature.
- (7) Standards New Zealand NZS 3603:1993 *Timber structures standard*. Under revision.
- (8) Standards Australia AS 1720.2-2006 *Timber structures*. Part 2 Timber properties.
- (9) Standards Australia and Standards New Zealand jointly AS/NZS 2878:2000 *Timber - Classification into strength groups*.
- (10) Standards New Zealand NZS 3631:1988 *New Zealand timber grading rules*.
- (11) Standards Australia AS 3818.6-2010 *Timber - Heavy structural products - Visually graded*. Part 6 Decking for wharves and bridges.
- (12) Standards Australia AS 3818.7-2010 *Timber - Heavy structural products - Visually graded*. Part 7 Large cross-section sawn hardwood engineering timbers.
- (13) Standards Australia AS 2858-2008 *Timber - Softwood - Visually stress-graded for structural purposes*.
- (14) Standards Australia AS 5100.9:2017 *Bridge design*. Part 9 Timber.
- (15) Standards Australia AS 1720.1-2010 *Timber structures*. Part 1 Design methods.
- (16) NZ Transport Agency (1989) *Strength and durability of timber bridges*. Road Research Unit bulletin 80. Wellington.
- (17) Lieberman GJ (1957) *Tables for one-sided statistical tolerance limits*. Technical report no. 34, Applied Mathematics and Statistics Laboratory, Stanford University, California for Office of Naval Research, USA.
- (18) Standards New Zealand NZS 3101.1&2:2006 *Concrete structures standard*. (Incorporating Amendment No. 3: 2017)
- (19) Canadian Standards Association (2014) S6-14 *Canadian highway bridge design code*.
- (20) NZ Transport Agency (2016) *Evaluation of shear connectors in composite bridges*. Research report 602, Wellington.
- (21) Ministry of Transport (2004) Land Transport Rule: Traffic Control Devices 2004 (plus subsequent amendments). Wellington.

8.0 Structural strengthening

In this section

	Section	Page
8.1	Introduction	8-2
8.2	Approvals	8-2
8.3	Durability	8-3
8.4	Existing structure material strengths	8-3
8.5	Strengthening of flexural members	8-4
8.6	Shear strengthening and ductility enhancement of reinforced concrete columns	8-14
8.7	References	8-15

8.1 Introduction

Strengthening or increasing the ductility of the members of structures may be required for a variety of reasons including increasing capacity for vehicle loads and improving earthquake resistance.

This chapter sets out criteria for the design of strengthening for concrete or steel structural members for the following situations, materials and techniques:

- The strengthening of members using bonded steel plates or fibre reinforced polymer composite materials.
- The strengthening of members using external prestressing.
- The shear strengthening and ductility enhancement of reinforced concrete columns using steel sleeves or fibre reinforced polymer composite materials.

AS 5100.8 *Bridge design* part 8 Rehabilitation and strengthening of existing bridges⁽¹⁾ provides guidance on many aspects of rehabilitation and strengthening of existing bridges to which reference may be made. In doing so the user will need to adapt the specification of loads and load factors therein to be consistent with those specified by this manual. AS 5100.8⁽¹⁾ appendix A in particular provides useful supplementary guidance on the application of fibre reinforced polymer strengthening to that specified by 8.5.5. On the design of timber elements, note that there are significant differences and inconsistencies between AS 5100.8⁽¹⁾ appendix D and AS 5100.9 *Bridge design* part 9 Timber⁽²⁾. AS 5100.9⁽²⁾ should be adopted in preference to AS 5100.8⁽¹⁾ appendix D for the design of timber elements.

Technologies for the strengthening of structures are continually under development. This chapter provides design criteria and guidance based on published information available at the time of preparation.

8.2 Approvals

Where a state highway structure is to be strengthened, a structure design statement shall be prepared and submitted to the NZ Transport Agency (NZTA) for acceptance. The materials and procedures for the proposed strengthening shall be fully described, including the criteria forming the basis of the design. The following shall be included:

- The mode of failure at the ultimate limit state and measures to be taken to ensure that other modes of failure are precluded.
- The strength reduction factors to be adopted for the various modes of action.
- Design standards and reference papers setting out and/or supporting the design criteria and design approach proposed.
- Durability issues and proposed mitigation measures.
- Intended remaining life of the structure and design life of the strengthening system.
- Quality assurance tests required for fibre reinforced composite materials used for strengthening the structure.

It is recommended that a structure design statement is similarly prepared for the strengthening of structures on other public roads and submitted to the relevant road controlling authority for acceptance.

8.3 Durability

8.3.1 General

The requirements of 2.1.6 of this manual shall be satisfied. Design life in this context shall be taken to be the intended remaining life of the strengthened structure.

Consideration shall be given to the vulnerability of the strengthening system to harmful hazards associated with the operational environment, including, but not limited to:

- exposure to water (marine, fresh or from industrial sources, and including the effects of wetting and drying)
- the effects of ground water and soil chemistry
- the passage of water and abrasion from material transported
- abrasion by traffic
- ultra violet light
- cycles of temperature variation
- freeze-thaw cycles
- heat or cold associated with the construction
- maintenance or operation of the structure
- fatigue
- stress corrosion
- strain aging
- galvanic corrosion
- exposure to fire
- exposure to lightning and stray electric currents
- acts of vandalism
- accidental impact, and
- chemical spillage.

Appropriate mitigation measures such as coating to protect the strengthening system shall be implemented.

8.3.2 Fibre reinforced polymer composites and adhesives

In addition to the requirements of 8.3.1 consideration shall be given to the effects of exposure to the following, as appropriate:

- contact with alkaline materials
- creep
- creep rupture
- glass transition temperature of the matrix (resin).

8.4 Existing structure material strengths

Where the characteristic strengths of the existing concrete, reinforcing steel, prestressing steel or structural steel are not known they shall be determined from testing as set out in 7.3.

8.5 Strengthening of flexural members

8.5.1 General requirements for the strengthening of reinforced concrete and prestressed concrete members

Strengthening shall, where appropriate, comply with, and be consistent with the requirements of NZS 3101.1&2 *Concrete structures standard*⁽³⁾.

Strength reduction factors used for assessment of the reliable strength at the ultimate limit state shall not exceed those given by NZS 3101⁽³⁾ clause 2.3.2.2.

8.5.2 General requirements for the strengthening of steel members

Strengthening shall, where appropriate, comply with, and be consistent with the requirements of the relevant standard for structural steel design as set out in 4.3.1.

Strength reduction factors or partial safety factors used for the assessment of reliable strength at the ultimate limit state shall not exceed those given by the relevant structural steel standard set out in 4.3.1.

8.5.3 Flexural strengthening of plastic hinge zones

Bonded steel plates, providing flexural strengthening at member sections at which plastic hinging is likely to occur under response to a design intensity earthquake event, shall be fully anchored outside the zone of plastic hinging. The impact of increased strength of plastic hinge zones on other elements of the load path shall be considered, with particular emphasis on beam-column joints abutting the enhanced plastic hinge zone, where appropriate upgrade may be very demanding. The bonded steel plates shall be fully confined over their length against buckling in accordance with the principles on which NZS 3101⁽³⁾ requirements for confining reinforcement are based.

Flexural strengthening using fibre reinforced polymer composites as primary flexural reinforcement, or using prestressing to increase the axial load on the section, shall not be applied at member sections at which plastic hinging is likely to occur under response to a design intensity earthquake event.

8.5.4 Strengthening using bonded steel plates

a. General and design principles

Design for the strengthening shall be undertaken at the serviceability limit state, based on the principles of elastic superposition and strain compatibility, and also at the ultimate limit state to ensure adequacy of strength and factor of safety against failure, with consideration to the mode of failure. The adequacy of the strengthened member for shear shall be confirmed.

The Highways England advice note BA 30 *Strengthening of concrete highway structures using externally bonded plates*⁽⁴⁾ provides guidance on design for strengthening using bonded steel plates and may be adopted subject to the modifications noted herein.

b. Applicability of strengthening using bonded steel plates

In the event of unexpected failure of the strengthening system, the structure shall remain capable of supporting its permanent loads plus nominal live load. A member shall only be considered suitable for strengthening by plate bonding if it can be shown to be at least capable of supporting the following when checked at the ultimate limit state (refer to 3.5 for definitions of the individual loadings):

$$1.20 (DL + EP + OW + SG + ST) + LLxI + FP$$

This amends BA 30⁽⁴⁾ clause 2.1.

Bonded steel plates shall not normally be used to provide resistance for significant permanent loads on the structure.

8.5.4 continued

c. Strength reduction factors

Strength reduction factors for section design at the ultimate limit state shall not exceed those given in NZS 3101⁽³⁾ clause 2.3.2.2 or the relevant standard for structural steel design as appropriate. Where the structure is deteriorated, the design strength reduction factors shall be modified as set out in table 7.5. The strength reduction factor (ϕ) shall not exceed 0.75 for the following aspects of design:

- i. plate peeling
- ii. plate development

The strength reduction factors adopted shall ensure that a flexural mode of failure (ie by plate yielding or concrete crushing) precedes failure by plate peeling or bond failure. This amends BA 30⁽⁴⁾ clause 3.2.

d. Brittle failure

The over-reinforcement of a concrete section can result in brittle failure. Sections to be strengthened should therefore be checked to ensure that this does not occur. The intent of NZS 3101⁽³⁾ clause 9.3.8.1 shall be complied with. This amends BA 30⁽⁴⁾ clause 3.3.

e. Fatigue

Fatigue of the bonded steel plate, the bonding material, and the reinforcement or structural steel section of the original member, under frequently repetitive imposed loads and forces on the structure shall be considered. For concrete members, NZS 3101⁽³⁾ clause 2.5.2 shall be complied with. NZS 3101⁽³⁾ clause 2.5.2.2 shall also apply to the stress range within the bonded steel plates. For steel members, the requirements of the relevant standard for structural steel design shall be complied with. This amends BA 30⁽⁴⁾ clause 3.5.

Where the strengthening is applied to the top surface of a structure's deck, consideration shall also be given to the fatigue effect from individual vehicle wheels applying normal and traction forces to the strengthening.

f. Yielding of original member reinforcement or section

The manner of strengthening shall be such that the reinforcement of an original concrete member, or part of the section of an original steel member, shall not be subjected to yielding under service loads to be imposed on the strengthened member.

g. Plate peeling

The phenomenon of premature failure of the bonded steel plates by plate peeling shall be taken into account and guarded against. The following principles are relevant:

- i. When a beam is subjected to a load perpendicular to its length, reactions are developed at its supports and the beam takes up a deflected shape. If strengthening in the form of bonded plates is added to the beam, to enable it to resist the load, then the plates must also take up a compatible deflected shape to that of the beam. This is brought about through the mobilisation of normal forces acting across the interface between the beam and the bonded plate, compressive towards the centre of the span and tensile in the end regions of the plate.
- ii. For the bonded plate to act as composite strengthening, it must take up strain such that as the beam deflects, plane sections remain plane, developing longitudinal shear stresses on the interface between the plate, adhesive and the face of the beam to achieve strain compatibility.

8.5.4 continued

Fixings shall be used to develop the normal forces and longitudinal shear stresses involved. In reinforced concrete members, tension in the cover concrete shall not be relied on for these actions. Where BA 30⁽⁴⁾ clause 3.7 is adopted as the basis for the design of fixings, the requirements of BA 30⁽⁴⁾ clause 3.4 shall also be satisfied. Fixings detailed in accordance with BA 30⁽⁴⁾ clause 3.7 shall be confirmed to provide adequate fixing for the normal forces in addition to the longitudinal shear forces, and shall also be detailed and confirmed to satisfy the other requirements of this clause, including (h) below.

In addition, the effect of yielding of the reinforcement in the original concrete member or of the original section of a steel member, at the ultimate limit state, on the level and distribution of bond stress along the member shall be taken into account and provided for. (*Retrofit of reinforced concrete members using advanced composite materials*⁽⁵⁾ provides a presentation of this effect in respect to reinforced concrete members.)

h. Truss analogy for reinforced concrete members

The mode of behaviour of a reinforced concrete beam can be considered to be analogous to a truss. When plate reinforcement is added to the soffit face of a reinforced concrete beam it lies outside the beam shear reinforcement, and in effect, the 'truss' web. A mechanism, other than tension in the cover concrete, shall be provided to incorporate that plate into the 'truss' action of the concrete beam.

Approaches that may be used to incorporate the plate into the 'truss' action of the concrete beam, effectively by extending the 'truss' web down to the level of the strengthening plate, include:

- bolting, lapped a development length with the beam shear reinforcement
- plates bonded to the side faces of the beam and attached to the flexural strengthening soffit plate, lapped a development length with the beam shear reinforcement, or
- fibre reinforced polymer strips wrapped around the flexural strengthening soffit plate and bonded up the side faces of the beam, lapped a development length with the beam shear reinforcement.

Where plates or fibre reinforced polymer strips bonded up the side faces of the beam are used to incorporate the soffit plate into the beam's 'truss' action, the top ends of these plates or strips shall be mechanically fixed to prevent them from peeling. On wide beams, a combination of side plates/strips and bolting may be necessary to prevent the soffit plate cross-section from bowing and to adequately incorporate the soffit plate into the beam's 'truss' action.

i. Effect of loading during curing on adhesive strength

Where the structure is subjected to live loading or other environmental loadings during curing of the adhesive, following installation of the steel plates, the effect of such loading on the final strength of the adhesive shall be taken into account.

j. Irregularity of the surface to which plates are to be bonded

The effect of irregularity of the bonding surface on the strengthening shall be taken into account, including the effects arising from deviation of the strengthening plate from perfect alignment (giving rise to a tendency for the plate to initially straighten when taking up load). The effect on the bond stresses from the strengthening plate not being perfectly aligned shall also be taken into account.

8.5.4 continued

k. Materials

Materials shall comply with BA 30⁽⁴⁾ section 4.

l. Surface preparation and corrosion protection

Surface preparation of the concrete and steel surfaces shall comply with BA 30⁽⁴⁾ section 5.

Interface steel surfaces may be protected against corrosion using a primer that is compatible with the initial bond primer and adhesive. Where a corrosion protection system is used, its effect on the bond strength of the interface shall be taken into account.

8.5.5 Strengthening using bonded fibre reinforced composite materials

a. General

Fibre reinforced polymer composite materials encompass a wide range of materials, manufactured by a number of different processes. The most commonly used fibre and resin materials, used to make up the composite materials covered by this clause, include the following:

- Fibre types: carbon, aramid, glass, and polyethylene.
- Resins: epoxy and vinyl ester.

Strengthening using bonded fibre reinforced polymer composites shall be in accordance with the same principles and requirements as set out in 8.5.4 for strengthening using bonded steel plates, except as modified below.

Many design guidelines are currently available that provide useful guidance on flexural and shear strengthening using fibre reinforced polymer composite materials (see 8.5.5(f)).

It is recommended, however, that *Guide for the design and construction of externally bonded FRP systems for strengthening concrete structures*⁽⁶⁾ is adopted for the design of strengthening. Note that 8.5.4(a) first paragraph and 8.5.4(b) shall apply.

Fibre reinforced polymer composites should not be applied to structural members containing corroded steel reinforcement or deteriorated concrete unless the substrate is repaired adequately. The existing substrate strength is important for bond critical strengthening applications such as flexural and shear strengthening of concrete members. The tensile strength of the existing substrate should be more than 1.4MPa as determined by a pull-off type adhesion test.

b. Track record, manufacturing processes and quality assurance

The fibre reinforced polymer composite material to be used shall have a track record of use in service that has demonstrated adequate durability. In addition, the product shall hold CodeMark certification that demonstrates that it complies with the current version of the *Building code*⁽⁷⁾ clauses:

- B1 Structure: clauses B1.1, B1.2, B1.3.1, B1.3.2, B1.3.3 and B1.3.4
- B2 Durability: clause B2.3.1
- E2 External moisture: clauses E2.3.2, E2.3.3, and E2.3.5
- F2 Hazardous building materials: clause F2.3.1

Listed conditions and limitations on the Certificate of Conformity shall be appropriate to the application to which the fibre reinforced polymer composite material is being put and the controls being exercised in the design and installation.

8.5.5 continued

The material shall be of adequate quality. This requires the choice of appropriate fibres and resins, combined in an appropriate manufacturing process with the necessary quality controls. The strength properties adopted for design shall be statistically based and have a confidence limit of not less than 95%, (ie not more than 5% of the test results will fall below the adopted design properties). The elastic modulus assumed for design shall be the mean value.

(As a guide to quality, *Guide for the design and construction of externally bonded FRP systems for strengthening concrete structures*⁽⁶⁾ presents tables of typical fibre properties for the different types of fibre reinforced polymers. Fibres of a fibre reinforced polymer would be expected to conform to these typical properties.)

The design shall use the composite properties recommended by the manufacturer, which shall be confirmed by testing in-situ samples prepared during the installation of the composites on site.

Adequate quality assurance testing shall have been undertaken to confirm the design properties of the composite, and quality control testing shall be undertaken during or post installation to ensure that the design properties are achieved.

c. Material characteristics, mode of failure, and strength reduction factors

In general, fibre reinforced polymer composite materials behave in a linearly elastic manner up to failure. They also, generally, have a significantly lower strength in compression than in tension. Externally bonded laminates or sheets are generally unsuitable for use in compression due to the impracticality of providing sufficient restraint against buckling.

The elastic moduli of fibre reinforced polymer composite materials vary widely dependent on the particular fibre type and on the mode of manufacture of the fibre reinforced polymer material. The elastic modulus of the particular composite material to be used for the strengthening shall be taken into account in the design.

For a reinforced or prestressed concrete beam strengthened using a fibre reinforced polymer composite material, three modes of failure are possible:

- i. by extensive yielding of the beam's original steel reinforcement, spalling of the compression cover concrete and moment capacity drop-off
- ii. by rupture of the fibre reinforced polymer composite flexural strengthening material
- iii. by brittle failure of the concrete in the member compression zone, or
- iv. de-bonding and peeling off of the fibre reinforced polymer composites from the substrates.

Where possible, for a strengthened concrete or steel section, the desired mode of behaviour is for the flexural steel reinforcement or structural steel section to yield prior to failure of the section, providing a noticeable increase in deflection and thereby warning of imminent failure.

In the case of failure of a concrete member by rupture of the fibre reinforced polymer composite flexural strengthening, the strain in the extreme concrete fibre in compression may be <0.003 when the ultimate tensile strain in the fibre reinforced polymer composite material is reached. As a result, the equivalent rectangular stress block adopted for concrete in the standard design procedure cannot be used.

A moment-curvature analysis, involving calculation of the neutral axis depth and strains in all the contributing materials, should be used for the analysis of the strengthened section.

8.5.5 continued

In addition to the nominal strength reduction factors (ϕ) specified below, additional strength reduction factors shall be applied as follows to allow for:

- Strength reliability - an additional factor (ψ_f) shall be applied to the contribution from the fibre reinforced composites to account for lower reliability of the fibre reinforced composites compared with internal steel reinforcement. As recommended in *Guide for the design and construction of externally bonded FRP systems for strengthening concrete structures*⁽⁶⁾, for the contribution of the fibre reinforced composites to flexural strength ψ_f shall be taken as 0.85. For the contribution of the fibre reinforced composites to shear strength ψ_f shall be taken as follows:

- o Where the FRP shear reinforcement is wrapped completely around the section* $\psi_f = 0.95$
- o Where the shear reinforcement is applied to three sides or two opposite sides of the section* $\psi_f = 0.85$

*As illustrated in figure 11.1 of *Guide for the design and construction of externally bonded FRP systems for strengthening concrete structures*⁽⁶⁾

- Environmental degradation - an environmental reduction factor (C_E) - shall be applied for the fibre reinforced composites based on exposure conditions. The *Guide for the design and construction of externally bonded FRP systems for strengthening concrete structures*⁽⁶⁾ proposes values for C_E to be used but does not adequately explain how these values have been derived or for what design life they are appropriate, and thus caution is required in their adoption. *FRP reinforcement in RC structures*⁽⁸⁾ and *Design guidance for strengthening concrete structures using fibre composite materials*⁽⁹⁾ provide more extensive discussions of environmental factors but similarly fail to adequately address the effect of the duration of exposure (ie the design life of the strengthening).

The effects of fatigue and stress rupture (alternatively referred to in some publications as creep rupture or stress corrosion) shall be taken into account. The *ACI Guide for the design and construction of externally bonded FRP systems for strengthening concrete structures*⁽⁶⁾ presents proposed stress limits for sustained plus cyclic service load stress limits in FRP reinforcement. The ACI guide⁽⁶⁾ advises caution if the FRP system is subjected simultaneously to extreme environmental and stress conditions. Note that these limits are allowable stress limits based on the ratio of the stress level at stress rupture after 500,000 hours (approx. 57 years) to the initial ultimate strength of the FRP with a factor of safety of 1.67 applied. The basis for considering these stress limits to be conservative and to be applicable to the combination of fatigue and stress rupture is not explained, and again the duration of exposure and number of cycles of fatigue loading should be taken into account. *FRP reinforcement in RC structures*⁽⁸⁾ provides an approach for extrapolation of the stress rupture stress limit out to 100 years, and some useful discussion is provided in *Design guidance for strengthening concrete structures using fibre composite materials*⁽⁹⁾.

In the application of fibre reinforced polymer composites, the approach proposed for the determination of allowable stress limits and the way that the various contributing factors have been taken into account shall be fully outlined in the structure design statement for acceptance by the road controlling authority. In particular the influence of the following factors shall be considered and discussed:

- design life for the strengthening works
- environmental factors (eg exposure to alkalinity, salt water, chemicals, ultra violet light, high temperatures, high humidity, and freezing and thawing cycles)

8.5.5 continued

- stress rupture
- fatigue.

For reinforced concrete, prestressed concrete and structural steel members, the strength reduction factors (ϕ) for flexural design of fibre reinforced polymer composite strengthening, at the ultimate limit state, shall be as follows:

- i. Where failure is preceded by a significant amount of ductile yielding, the strength reduction factor shall not be greater than $\phi=0.85$.
- ii. Where the mode of failure is non-ductile, the strength reduction factor shall not be greater than $\phi=0.75$.

The strength reduction factor (ϕ) shall not be greater than 0.75 for the following aspects of design:

- i. Laminate or sheet peeling.
- ii. Laminate or sheet development.

The strength reduction factors adopted shall ensure that a flexural mode of failure (eg by rupture of the fibre reinforced polymer composite material or concrete crushing) precedes failure by peeling or bond failure.

Where fibre reinforced polymer strengthening material may be exposed to the effects of fire, as outlined in AS 5100.8⁽¹⁾ appendix A clause A2.6, those effects shall be considered and designed for as required by AS 5100.8⁽¹⁾ appendix A clause A2.6.

d. Method of analysis

Elastic analysis shall be used to analyse the structure, and no redistribution of the elastic bending moments and shear forces is permitted in view of the lack of ductility of the fibre reinforced polymer composite material. This amends NZS 3101⁽³⁾ clause 6.3.7.

e. Strengthening of concrete members for shear

Concrete members strengthened for shear by using strips (laminates) or sheets of fibre reinforced polymer composite material shall be designed for shear in accordance with the requirements of NZS 3101⁽³⁾ chapter 7 and chapter 9. Under these requirements, fibre reinforced polymer composite strip reinforcement shall be treated in the same manner as steel reinforcement with the stress in the fibre reinforcement corresponding to a strain of 0.004 substituted in place of the steel yield stress. Under these conditions, the contributions to shear reinforcement of the existing steel reinforcement and of the fibre reinforced polymer composite strip reinforcement may be considered additive.

In addition to the nominal strength reduction factor (ϕ), additional strength reduction factor (ψ_f in *Guide for the design and construction of externally bonded FRP systems for strengthening concrete structures*⁽⁶⁾) shall be applied to the contribution from the fibre reinforced composites to account for lower reliability of the fibre reinforced composites compared with internal steel reinforcement. ψ_f is considered as 0.95 for completely wrapped members and 0.85 for three-sided U-wraps for the shear strength contribution of the fibre reinforced composites.

Note an environmental reduction factor (C_E) shall be applied for the fibre reinforced composites based on exposure conditions as recommended in *Guide for the design and construction of externally bonded FRP systems for strengthening concrete structures*⁽⁶⁾.

8.5.5 continued

The ends of fibre reinforced polymer composite strips shall be adequately anchored in the compression zone of the concrete section to develop the design forces in the strips. In situations where a slab overlies a beam being strengthened (as with a T-beam), the preferred approach is for intermittent slots to be cut in the slab and the fibre reinforced polymer strips passed through the slab to be anchored in the compression zone (above the neutral axis) of the concrete section.

Where the strips are to be terminated below a slab, consideration shall be given to the transfer of the force in the fibre reinforced polymer strips to the 'truss' mechanism of the reinforced concrete member, and to the shear that may be induced in the concrete member above the level of the ends of the strips. (*Retrofit of reinforced concrete members using advanced composite materials*⁽⁵⁾ and other references in 8.7 provide guidance on this issue.)

Depending on the manufacturing process, the strength of fibre reinforced polymer composite material shear reinforcement may be significantly less locally at corners than within straight portions. This shall be taken into account in the design.

f. Design guidelines

A number of design guidelines related to bonded fibre reinforced composite materials have been published internationally. There are differences in approach between the guidelines and it is recommended that the following two manuals are adopted for concrete and steel structures respectively:

- *Guide for the design and construction of externally bonded FRP systems for strengthening concrete structures*⁽⁶⁾
- *Strengthening metallic structures using externally bonded fibre-reinforced polymers*⁽¹⁰⁾.

This area is the subject of evolving technology. Hence well-corroborated specialist information such as available from some manufacturers may be useful. Further guidance can also be sought from:

- AS 5100.8⁽¹⁾
- *Retrofit of reinforced concrete members using advanced composite materials*⁽⁵⁾
- *Design guidance for strengthening concrete structures using fibre reinforced composite materials*⁽⁹⁾
- *Design and use of externally bonded FRP reinforcement for RC structures*⁽¹¹⁾
- *Use of fibre reinforced polymers in bridge construction*⁽¹²⁾
- *Alternative materials for the reinforcement and prestressing of concrete*⁽¹³⁾

Reliance on sources other than those recommended is to be identified and justified in the structure design statement, and the road controlling authority's acceptance obtained before committing to its use.

g. Quality assurance tests

Strengthening with fibre reinforced composites shall be evaluated for conformance with the design drawings and specifications. Evaluation shall include the following, but the list is not exhaustive:

- i. fibre reinforced composite properties
- ii. installation tolerances - fibre orientation, cured thickness, width and spacing, corner radii, and lap splice
- iii. presence of delaminations
- iv. cure of resins
- v. adhesion to the substrate.

8.5.5 continued

Sample panels made on site and pull-off tests can be used to evaluate the installed strengthening system. *Guide for the design and construction of externally bonded FRP systems for strengthening concrete structures*⁽⁶⁾ provides guidance on evaluation methods.

8.5.6 Strengthening using external prestressing

a. Applicability

This clause is applicable to strengthening by externally prestressing members using conventional systems based on steel prestressing. This clause does not cover the use of fibre reinforced polymer prestressing systems. There are guidelines however, that provide advice on the design of fibre reinforced polymer tendons. The following references are provided for information only:

- *Prestressing concrete structures with FRPs*⁽¹⁴⁾
- *Strengthening structures with externally prestressed tendons: literature review*⁽¹⁵⁾
- *Design recommendations for concrete structures prestressed with FRP tendons*⁽¹⁶⁾

Specific approval shall be obtained from the road controlling authority if FRP tendons are proposed to strengthen a structure.

b. Inspection, maintenance and demolition

Adequate provision shall be made for the inspection and maintenance of external tendons.

All external and unbonded tendons shall be individually replaceable without having to restrict traffic on the highway wherever possible. Where the detailing does not enable tendons to be removed and replaced without damage to either the tendons or the structure, or without restricting traffic, a method statement defining how the tendons can be replaced shall be provided in the structure design statement. A method statement defining how the structure can be demolished shall also be provided.

c. Strengthening of concrete members

NZS 3101⁽³⁾ provides explicitly for the design of structures with unbonded high strength steel tendons and shall be complied with for this form of strengthening, except as modified herein.

Conventionally reinforced, non-prestressed concrete members that are strengthened by external unbonded prestressing shall satisfy the serviceability limit state crack width criteria for reinforced concrete set out in NZS 3101⁽³⁾ commentary clause C2.4.4.6. The more stringent criteria for prestressed concrete need not be complied with.

d. Strengthening of steel and composite steel - concrete members

Section 8.5.2 shall apply in respect to stresses induced in the steel sections and to the design of anchorages and deviators. In the consideration of buckling of the steel section, the prestress force may be considered as an externally applied load.

For the design of the stressing tendons, the principles and requirements of NZS 3101⁽³⁾ clauses 19.3.1 and 19.3.6 should be applied as appropriate.

The strengthened members shall meet both the serviceability and ultimate limit state requirements of the relevant standard for structural steel design, and where the members include a composite concrete element, the relevant serviceability and ultimate limit state requirements of NZS 3101⁽³⁾.

8.5.6 continued

The strength reduction factor (ϕ) adopted for determining the reliable flexural capacity at the ultimate limit state shall be derived from the relevant standard for structural steel design.

e. Anchorages and deviators

Anchorages and deviators for external tendons shall be designed at the ultimate limit state for a load equal to at least 95% of the ultimate tensile strength of the tendons with a value of $\phi=0.85$. Where serviceability checks are required, as for flexural cracking in concrete deviator beams, the design service load in the tendons shall be taken as the tendon load before long-term losses.

The design shall ensure that bi-metallic corrosion between the tendons and their anchorages is prevented.

f. Tendons pretensioned before being deflected

For single tendons the deflector in contact with the tendon shall produce a radius of not less than 5 times the tendon diameter for wire, or 10 times the diameter for strand. The total angle of deflection should not exceed 15°.

g. Post-tensioned tendons profile

In the absence of test results or other investigation justifying smaller values, the radius of curvature of tendons in deviators should not be less than the minimum values in table 8.1.

Table 8.1: Radius of curvature for tendons

Tendon (strand number - size)	Minimum Radius (m)
19 - 13mm and 12 - 15mm	2.5
31 - 13mm and 19 - 15mm	3.0
53 - 13mm and 37 - 15mm	5.0

h. Tendon restraint

External tendons shall be restrained in all necessary directions to avoid unacceptable second order effects due to beam deflections and tendon vibration.

i. Corrosion protection

Tendons shall be protected to ensure that their life is compatible with the life of the structure.

j. Further considerations to be taken into account

The design shall take into account the following:

- The effects of end restraint of the spans/beams being stressed, whether due to the spans being constructed integral with supports, or due to friction or elastomeric shear strain of bearings.
- The distribution of the prestress force and induced moment across all the beams making up the total cross-section, as influenced by:
 - o which beams are to be prestressed and by how much
 - o the relative stiffness of the beam elements making up the total cross-section
 - o within each span, the length over which the prestressing is to be applied and shear lag effects across the structure's deck.

8.5.6 continued

- The effects of secondary moments arising from continuity of the span or from spans being constructed integral with supports.
 - The effects of shortening of the spans due to the initial prestress force and long-term creep.
- k. Guidance documents

General guidance on considerations related to the design of systems for external prestressing is provided by *Materials and systems for external prestressing*⁽¹⁷⁾.

8.6 Shear strengthening and ductility enhancement of reinforced concrete columns

8.6.1 General

Strengthening shall, where appropriate, comply with, or be consistent with the requirements of the NZS 3101⁽³⁾.

Strength reduction factors used for the assessment of reliable strength at the ultimate limit state shall not exceed those given by NZS 3101⁽³⁾ clause 2.3.2.2.

Extensive design guidance is provided by *Seismic design and retrofit of bridges*⁽¹⁸⁾ covering both strengthening using steel plate sleeves and using fibre reinforced polymer composite materials. The design approaches and recommendations contained therein may be adopted in place of the requirements of NZS 3101⁽³⁾ and will generally result in a more economical design.

8.6.2 Shear strengthening and ductility enhancement of reinforced concrete columns using steel sleeves

Concrete members strengthened for ductility or shear by using steel sleeves shall be designed in accordance with the requirements of NZS 3101⁽³⁾. Alternatively, the design recommendations of *Seismic design and retrofit of bridges*⁽¹⁸⁾ may be adopted.

Strengthening to ensure the integrity of flexural reinforcing bar lap splices shall comply with the design recommendations of *Seismic design and retrofit of bridges*⁽¹⁸⁾.

8.6.3 Shear strengthening and ductility enhancement of reinforced concrete columns using fibre reinforced polymer composite materials

Concrete members strengthened for ductility or shear by using fibre reinforced polymer composite material shall be designed in accordance with the requirements of NZS 3101⁽³⁾. Under these requirements, fibre reinforced polymer composite strip reinforcement shall be treated in the same manner as steel reinforcement with the stress in the fibre reinforcement corresponding to a strain of 0.004 substituted in place of the steel yield stress. Under these conditions, the contributions to confinement or shear reinforcement of the existing steel reinforcement and of the fibre reinforced polymer composite strip reinforcement may be considered additive. Alternatively, the design recommendations of *Seismic design and retrofit of bridges*⁽¹⁸⁾ may be adopted.

Strengthening to ensure the integrity of flexural reinforcing bar lap splices shall comply with the design recommendations of *Seismic design and retrofit of bridges*⁽¹⁸⁾.

8.7 References

- (1) Standards Australia AS 5100.8: 2017 *Bridge design*. Part 8 Rehabilitation and strengthening of existing bridges.
- (2) Standards Australia AS 5100.9:2017 *Bridge design*. Part 9 Timber.
- (3) Standards New Zealand NZS 3101.1&2:2006 *Concrete structures standard*. (Incorporating Amendment No. 3: 2017)
- (4) Highways England (1994) BA 30/94 *Strengthening of concrete highway structures using externally bonded plates*. TSO, London, United Kingdom. Withdrawn.
- (5) Wang YC (2000) *Retrofit of reinforced concrete members using advanced composite materials*. Department of Civil Engineering research report 2000-3, University of Canterbury, Christchurch.
- (6) American Concrete Institute (2008) *Guide for the design and construction of externally bonded FRP systems for strengthening concrete structures*. ACI Report 440.2R-08, Detroit, MI, USA.
- (7) Parliamentary Counsel Office (1992) *Building Regulations 1992*. Schedule 1 *The building code*. Wellington.
- (8) Federation Internationale du Béton (2007) *FRP reinforcement in RC structures*. *fib Bulletin* 40, Lausanne, Switzerland.
- (9) The Concrete Society (2012) *Design guidance for strengthening concrete structures using fibre reinforced composite materials*. 3rd edition. Technical report 55, The Concrete Society, United Kingdom.
- (10) Construction Industry Research and Information Association (2004) CIRIA C595B *Strengthening metallic structures using externally bonded fibre-reinforced polymers*. London, United Kingdom.
- (11) Federation International du Béton (2001) *Design and use of externally bonded FRP reinforcement for RC structures*. *fib Bulletin* 14, Lausanne, Switzerland.
- (12) Keller T (2003) *Use of fibre reinforced polymers in bridge construction*. Structural Engineering Documents 7, International Association for Bridge and Structural Engineering, Zurich, Switzerland.
- (13) Clarke JL (1993) *Alternative materials for the reinforcement and prestressing of concrete*. CRC Press, Boca Raton, FL, USA.
- (14) Campbell I (2008) *Prestressing concrete structures with FRPs*. Manual No 5, ISIS Canada.
- (15) Nordin H (2005) *Strengthening structures with externally prestressed tendons: literature review*. Technical report, Luleå University of Technology, Sweden.
- (16) Dolan CW, Hamilton III HR, Bakis CE and Nanni A (2001) *Design recommendations for concrete structures prestressed with FRP tendons*. Report for FHWA contract DTFH61-96-C-00019.
- (17) Federation Internationale du Béton (1996) *Materials and systems for external prestressing*. FIP report, Lausanne, Switzerland.
- (18) Priestley MJN, Seible F and Calvi GM (1996) *Seismic design and retrofit of bridges*. John Wiley & Sons Inc, New York, NY, USA.

(This page is intentionally blank)

Superseded

Appendix A Bridge widths and clearances

In this section

	Section	Page
A1	General	A-2
A2	Bridge deck widths	A-6
A3	Vertical and horizontal clearances	A-11
A4	References	A-13

A1 General

A1.1 General

- a. In assessing the appropriate width for a structure, a designer should take into account its context and purpose, as well as its value for money. Consideration should be given to its current and future use, particularly in catering for vulnerable users and connectivity to the surrounding network.
- b. As a general principle, the widths of traffic lanes and shoulders, together with any additional facilities for pedestrians, cyclists and equestrians on a bridge shall be consistent, wherever practicable, with those of the road on the approaches. This also applies where roads cross over culverts, stock underpasses and subways. Where there are variations, the transitions between these shall be effected at a rate appropriate to the speed environment in order to minimise the impact on the lane edge-line and driving alignment.
- c. Typical bridge deck details for various one and two-lane situations are illustrated in figure A1. These details are indicative and should be considered as guidance when considering the site specific constraints of individual cases. They apply both to bridge decks and to the roof slab of culverts, stock underpasses and subways that are not buried but directly carry the road carriageway.
- d. The geometric requirements presented in tables A1 to A6 and figures A1 and A4 apply to state highways and may apply to non-state highways. Any variation from these requirements shall be at the discretion of the road controlling authority.
- e. The 'desirable' values given in the tables are generally preferred but partial or full reductions to the 'minimum' values may be acceptable based on value for money.

The preparation of the business case and the structure design statement shall take account of all relevant factors and provide a balanced value for money assessment to provide the optimum outcome for the project. This assessment could include different options for a decision by the road controlling authority.

Further information on the derivation of the desirable values and the appropriate process is provided in the guidance notes in A2(c).

- f. The 'minimum' values given in the tables are the lowest acceptable value for a dimension or parameter. These values should be exceeded wherever practicable.
- g. Specific consideration shall be given to providing for cyclists, over and above the requirements of pedestrians. (Refer to the Austroads *Guide to road design* part 3 Geometric design⁽¹⁾.)

A1.2 Medians

- a. Where the traffic lanes are separated by a median, it is desirable that the widths of the median and the type and level of protection provided by a safety barrier within the median are consistent with the approaches to the bridge.
- b. Where the requirements of (a) are not practicable, the width of the median may be varied provided that the tapers applied to any changes in width are consistent with the speed environment and provide a smooth driving alignment.

A1.3 Use of kerbs on bridges

A1.3.1 General

- i. Kerbs should only be used if any of the following apply:
 - As a continuation of a kerb on the approach with matching profile type. Note that a kerb on the bridge has a maximum height of 100mm and therefore a transition may be required from the approach kerb.

A1.3 continued

- As delineation for a footpath.
 - To provide control of surface water.
- ii. Examples of common kerb profiles are shown in figure A2.
 - iii. Kerb height should be limited to a maximum of 100mm (channel lip to kerb top) so that they do not adversely affect the performance of the edge protection or interfere with bicycle pedals.
 - iv. Where a kerb is required adjacent to a road safety barrier, in order to avoid adverse effects on the barrier performance, it is desirable that the vertical face of the kerb be placed vertically below the barrier face. If this is not practical, notwithstanding the requirements of (v), then the vertical face of a vertical or semi-mountable kerb should be no greater than 200mm in front of the face of the barrier. This restriction does not apply to the location of fully mountable kerbs.
 - v. Where a kerb is provided adjacent to a footpath
 - in >50km/h
 - o A mountable profile is preferred and must be used where the edge protection is semi-rigid.
 - o A semi-mountable kerb may be used where the edge protection is rigid.
 - o A minimum offset of 1.5m must be provided from the kerb face to the face of the edge protection.
 - o For a single lane bridge, the footpath may be reduced to 1.0m provided that the kerb does not have a vertical profile.
 - in ≤50km/h
 - o A vertical profile may be used where it is present on the approaches.

A1.3.2 Barrier kerbs

- i. 'Barrier kerb' is the term traditionally applied only to the kerb whose profile approximates to that given in B2.7.
- ii. Barrier kerbs shall not be used on new structures. They may only be used on existing structures in exceptional circumstances with the agreement of the road controlling authority. Historically, they were intended to provide additional restraint to errant vehicles where the side protection was inadequate.

A1.4 Side protection

The distance from the face of a non-rigid traffic barrier to the deck edge is required to accommodate the designed deflection of the barrier under vehicle impact and keep the vehicle wheels on the deck, as described in table A2. On single-lane bridges only the distance may be reduced to 270mm for semi-rigid barriers (figure A1 - types 3 and 4), where the slab is sufficiently deep for the barrier posts to be fixed to the side of the deck. This is on the basis that the vehicle impact angle will usually be smaller due to the restricted width of carriageway, resulting in smaller barrier deflections.

Where there is a footpath (or combined facility catering for more than one of pedestrians, cyclists and equestrians), there are two options:

- i. to use a kerb between the shoulder and the footpath (or combined facility) and a combination barrier (traffic safety barrier with an appropriate top-rail) at the edge of the deck.
- ii. to place a traffic barrier between the shoulder and the footpath (or combined facility) with a pedestrian (cyclist or equestrian) barrier at the edge of the deck.

Option (i) is the normal arrangement. Option (ii) should be considered where there is likelihood of prolonged pedestrian presence or the alignment of the bridge increases the risk of a vehicle losing control (eg outside of curves).

A1.4 continued

Where the traffic barrier is placed between the shoulder and the footpath, consideration should be given to providing additional height protection. Furthermore, careful consideration should be given to the termination of these barriers off the bridge.

Figure A1: Typical bridge deck details

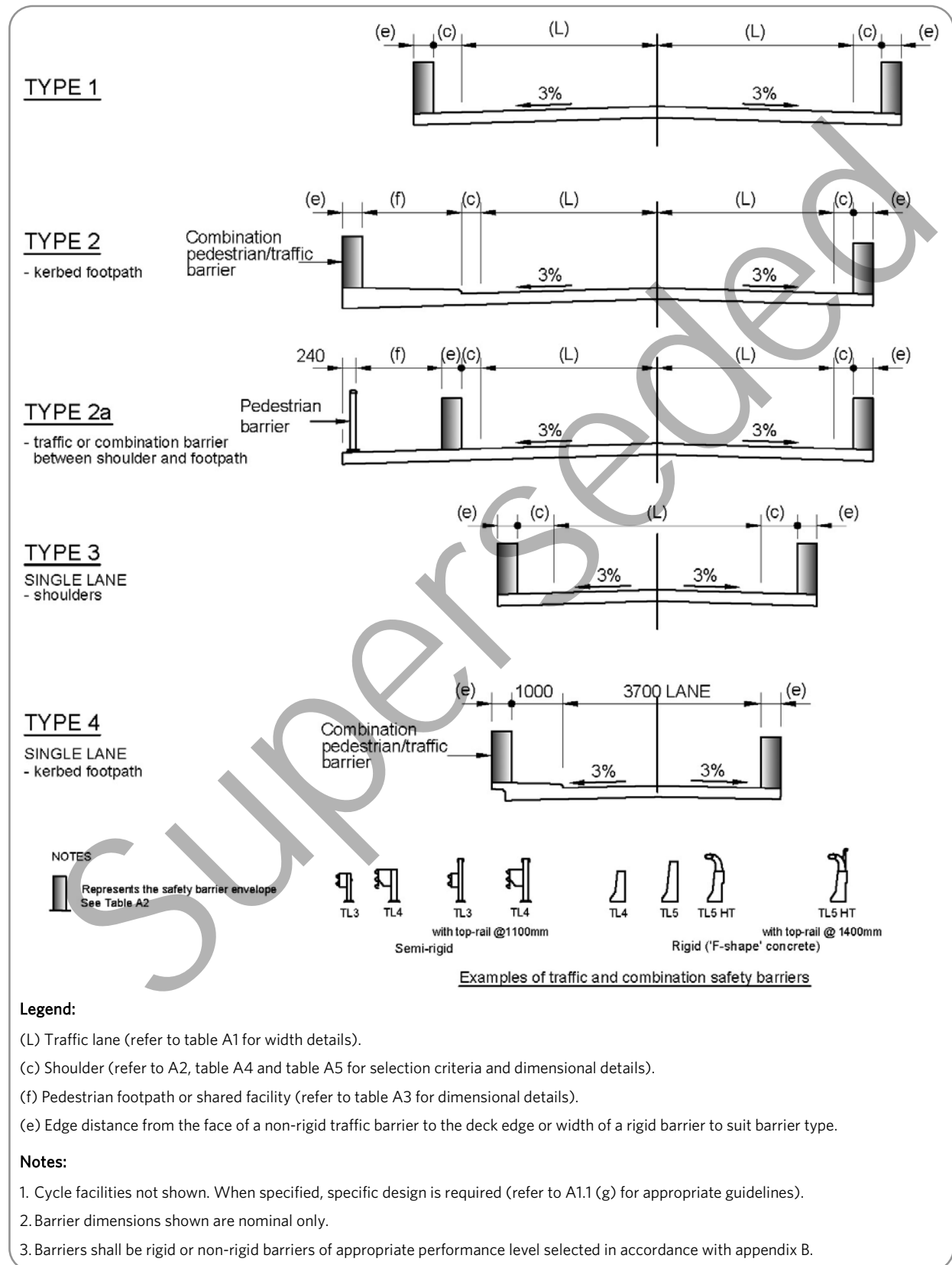

A1.5 Footpath

The term 'path' has been used to refer to facilities for the exclusive or shared use of pedestrians, cyclists and equestrians. This differs from the Austroads *Glossary of terms*⁽²⁾ in respect of facilities on bridges.

The need to cater for pedestrians, cyclists and equestrians on a bridge shall generally be determined at scheme assessment stage, according to the local and regional pedestrian, cycle and equestrian demand. The width of these facilities shall be as defined in table A3.

A footpath behind a non-rigid barrier may be reduced in width at the posts, on the basis that this maintains clearance to the rear of the barrier rail.

The minimum width of combined facilities should be consistent with that of the approaches to the bridge. This may be increased to cater for future demand.

Further guidance on provisions appropriate for pedestrians, cyclists and equestrians may be found in the following publications:

- For pedestrians and cyclists:
 - Austroads *Guide to road design* part 3⁽¹⁾ and part 6A Pedestrian and cyclist paths⁽³⁾.
- For equestrians:
 - TA 91 *Provision for non-motorised users*⁽⁴⁾.
 - TA 90 *The geometric design of pedestrian, cycle and equestrian routes*⁽⁵⁾.

A1.6 Bridges for non-motorised users

For a dedicated pedestrian/cycling/equestrian bridge, the width should be appropriate for the required and anticipated network demand. A clear width of 3.0m is considered desirable for a shared facility.

Figure A2: Examples of typical kerb profiles for bridges

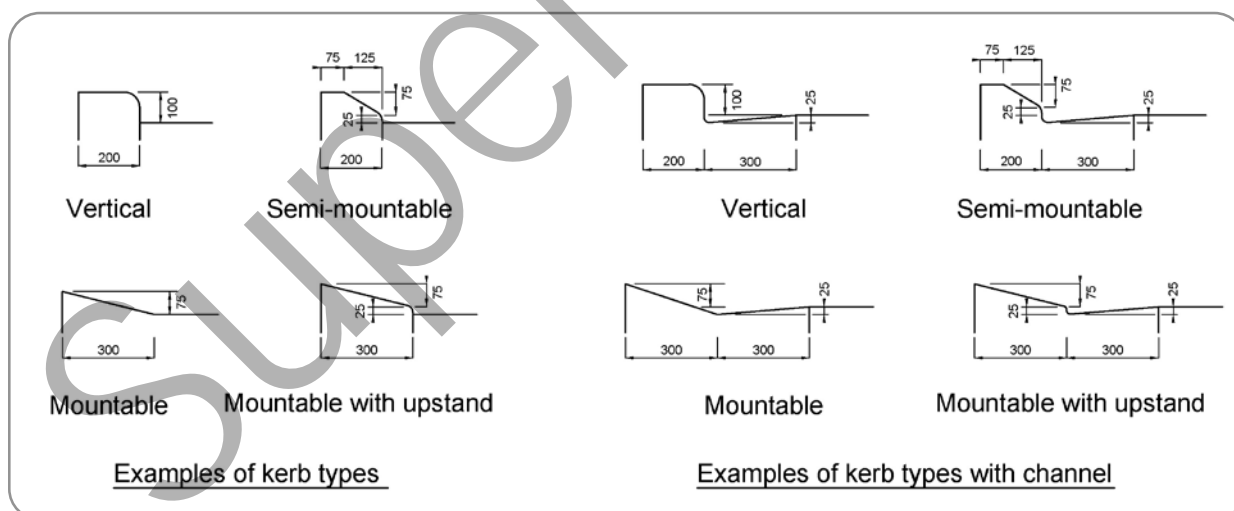

A2 Bridge deck widths

- a. Deck width is the sum of the individual elements required to make up the desired bridge cross-section. A flowchart to aid in the determination of bridge widths is shown in figure A3. Bridge carriageway requirements are:

i. Full approach road carriageway

The full width of the approach traffic lanes and shoulders required for a road carrying the expected AADT (annual average daily traffic) 30 years ahead shall be provided across bridges unless otherwise agreed by the road controlling authority.

ii. All other situations

The carriageway width required shall be determined by the minimum traffic lane width given in table A1. Note that traffic lanes may need to be widened on curved bridges to accommodate the tracking widths required by large commercial vehicles.

Edge clearances are selected using the following criteria:

1. Provide kerbs, shoulders and footpaths on the structure consistent with the approach road cross-section;
 2. Where a segregated (off-road) pedestrian, cycle or equestrian facility is provided on the approach, this segregation should desirably be continued over the bridge (figure A1 - type 2a).
 3. Where an approach footpath is contiguous with the carriageway or shoulder on the approach, the edge treatment (kerb) shall desirably be continued across the bridge (figure A1 - type 2).
 4. The kerb face or channel low point shall be placed at the back of the shoulder (ie the width of the kerb is part of the footpath and the width of the channel is part of the shoulder).
 5. Where the anticipated usage of the path is high, it will be used by vulnerable users or will be a shared facility, preference should be given to inserting a barrier between the footpath or shared path and the shoulder (figure A1 - type 2a). In this case, specific consideration should be given to the treatment of the barrier terminals beyond the bridge and to maximising dimension (c) to allow additional clearance for cyclists. Note that an additional barrier is required on the outside of the path that should be appropriate for the usage (eg pedestrian barrier 1.1m high, cyclist barrier 1.4m high, equestrian barrier 1.8m high).
 6. Where there is neither kerbing nor footpath on the approach road then clearance between a safety barrier and the adjacent traffic lane shall be provided in accordance with table A5.
- b. The carriageway widths required for standard, straight, 2 x 3.5m lane, state highway bridges relating to the traffic volume from A2(a)(i) and (ii), are summarised in table A6. Note that for AADT <2000 vehicles per day (vpd), the current standards for approach carriageway widths may be less than those recommended for bridge widths.
-

A2 continued

c. Guidance notes

The philosophy applied to the process used to establish the deck width has been changed to be more consistent with the rest of the highway network. Essentially, the designer should take into account the amenity provided by the road cross section on each side and at both ends of the structure and the need for future-proofing.

For example, if a rural highway has a typical cross-section of 3.5m lanes and 1.5m shoulders, without kerbs or any specific facilities for pedestrians then this will be the default cross-section over the structure. If there is a kerb on the approach however, it would be prudent to establish why the kerb is there in the first place (eg surface water control or delineation – particularly if there is a footpath or shared path). The kerb should then either be continued over the bridge or aligned with the barrier system appropriately.

Consideration should also be given to future-proofing the structure, particularly in respect of pedestrians in line with local authority policy. If a footpath is to be provided on one or both sides of the structure, then this will usually be delineated by a mountable or semi-mountable kerb. If this is just a footpath, then the desirable shoulder width should be considered in order to cater for cyclists. If this is to be a shared path, then it will usually be wider than just a footpath and a mountable kerb would be preferred to ensure user safety. The minimum shoulder width may be considered appropriate for shoulders adjacent to shared paths.

If the shared path is two-way, or where the pedestrian or cyclist traffic may be tempted to stop on the structure (eg a lookout), then consideration should be given to separating this facility from the highway by placing a road safety barrier system at the back of the shoulder. This barrier system may have a pedestrian or cycle rail added as required. Careful consideration should be given to the barrier system terminal end details to ensure that the required protection of the roadside hazard is continuous on the bridge approaches. This configuration should be considered where there an 'off-road' facility that uses the structure to cross a hazard even if this facility is not adjacent to the highway on the approach.

Table A1: Traffic lanes

Description	Width (L)
The width of traffic lanes shall be as specified in the Austroads <i>Guide to road design</i> Part 3 ⁽¹⁾ section 4.2.4 unless specified otherwise by the road controlling authority. Good geometric design practice including curve widening criteria to accommodate heavy vehicle tracking (particularly relevant to low radius horizontal curves) should be applied to determine appropriate bridge and approach traffic lane widths.	3.50m (desirable)

Figure A3: Flowchart to determine bridge width

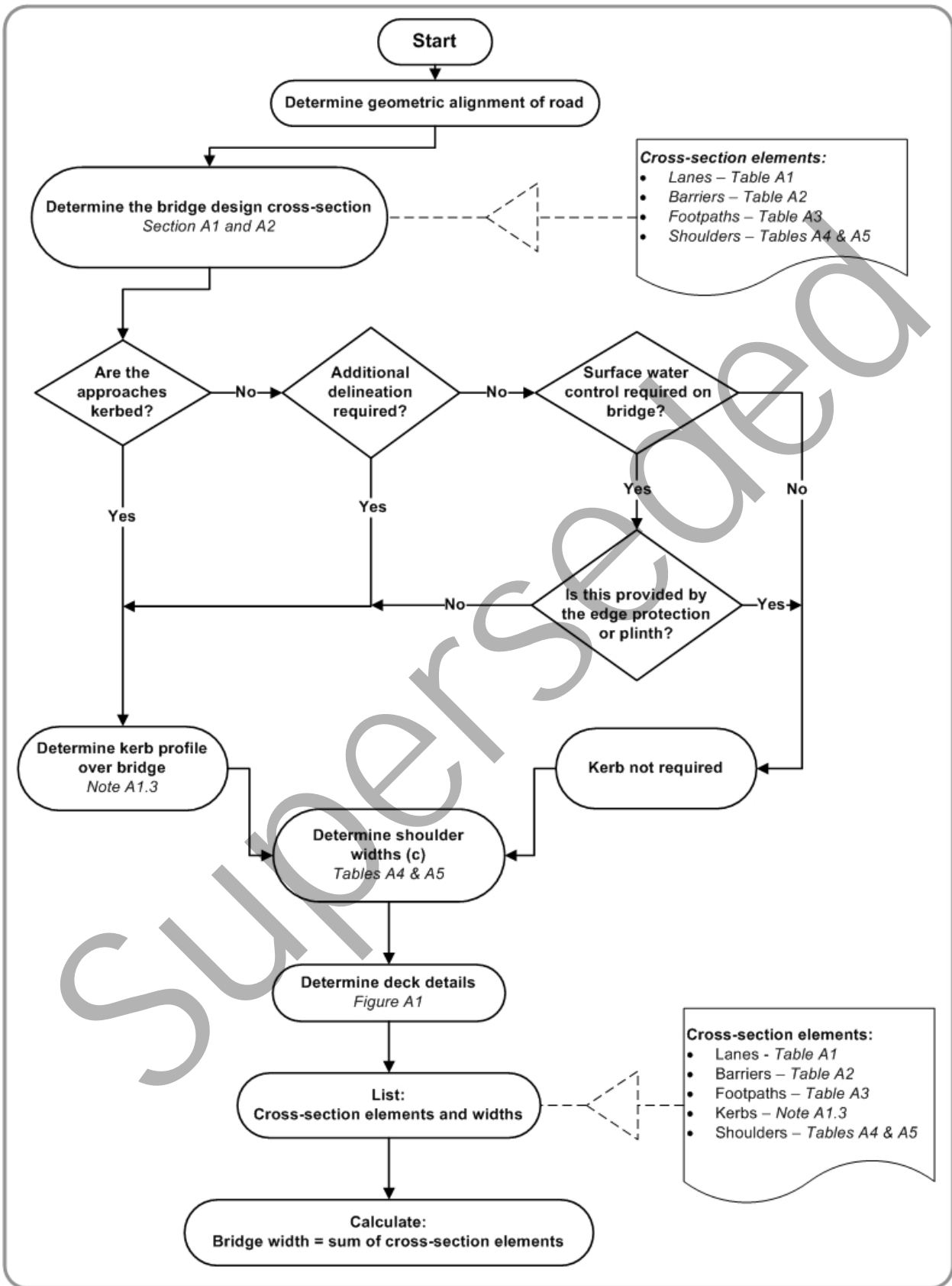

A2 continued

Table A2: Bridge barriers

Element	Horizontal dimension (e)
Rigid traffic barrier (actual dimension governed by barrier system employed)	400mm (TL-4 monolithic 915mm high) 450mm (TL-5 HT type 1270mm high) (nominal)
Inside face of pedestrian barrier to edge of deck (top fixed)	240 mm (minimum)
Traffic face of semi-rigid safety barrier to edge of deck (top fixed) - based on nominal test deflection	800mm (TL-3 W-beam) 900mm (TL-4 Thrie-beam) (minimum)

Table A3: Bridge footpaths

Footpath width	Horizontal dimension (f)
In general situations:	
– desirable	2.00m
– shared desirable (pedestrian and cyclist and/or equestrian)	2.50m
– minimum (with kerb)	1.50m
– minimum (without kerb)	1.30m
Behind a semi-rigid barrier post	
– desirable	1.70m
– minimum	1.00m

Table A4: Clearances between kerbs and adjacent traffic lanes (shoulder widths)

Kerb type on approach	Kerb type on bridge	Shoulder width (c)
Kerbed	Preferred mountable or semi-mountable to match approach	See table A5
	Vertical kerb - to match approach road kerb only in speed environment of 50km/h or less ¹	1500mm desirable (600mm minimum)
No kerb	No kerb (preferred) or mountable	See table A5

Notes:

- Where a kerb is not present on the approach, the preference is to not have a kerb over the bridge. However, if one is required for delineation or control of surface water then a mountable profile should be used.
- Where a kerb is used, the face of kerb should be placed at the back of the shoulder
- Desirable width should be used for cyclist safety
- For cycle facilities refer to A1(f).

A2 continued

Table A5: Clearances between bridge safety barriers and adjacent traffic lanes (shoulder widths)

For use only where the approach road cross-section cannot be continued over the structure or the shoulder width on the approach is less than the desirable value.

Road type		Shoulder width (c)
Low volume one-lane or two-lane roads (AADT <500)		600mm desirable 300mm minimum
Medium volume two-lane roads:		
– AADT 500 - 2000		750mm desirable 600mm minimum
– AADT 2000 - 4000		1000mm desirable 600mm minimum
High volume two-lane roads (AADT >4000)		1500mm desirable 1200mm minimum
Divided roads and motorways	Nearside (LHS)	2500mm desirable 1200mm minimum
	Median (RHS)	1600mm desirable ^{8,9} 600mm minimum

Notes:

- Traffic volumes are expected AADT 30 years ahead.
- Desirable clearances shall apply where the approach road cross-section cannot practicably continue over the bridge or the shoulder widths on the approaches are less than the desirable value.
- Minimum clearances should only be used in extreme conditions, ie where it is physically impracticable to provide the normal clearance. There should be compelling reasons documented to justify the use of reduced clearances.
- For cycle facilities refer to A1(f).
- Clearances apply where shown in figure A1.
- Clearances should be increased on the inside of curves as required to provide the appropriate sight distance.
- Clearances do not satisfy shy-line requirements to Austroads *Guide to road design part 6 Roadside design, safety and barriers*⁽⁶⁾ table 6.4.
- Based on a rigid barrier.
- Where split structures are used for dual carriageways, the desirable shoulder width shall be used at the right hand edge of the running lane.

Table A6: Two-lane state highway bridge carriageway widths

AADT (vpd)	Desirable carriageway width (m)	Minimum carriageway width (m)
>4000	10.0 (2x3.5 + 2x1.5)	9.4 (2x3.5 + 2x1.2)
2000 - 4000	9.0 (2x3.5 + 2x1.0)	8.2 (2x3.5 + 2x0.6)
500 - 2000	8.5 (2x3.5 + 2x0.75)	8.2 (2x3.5 + 2x0.6)
<500	8.2 (2x3.5 + 2x0.6)	7.6 (2x3.5 + 2x0.3)

Notes:

- Traffic volumes are expected AADT 30 years ahead.
- See notes associated with table A5.

A3 Vertical and horizontal clearances

Vertical and horizontal clearances at all overhead or adjacent obstructions shall conform with figure A4.

Figure A4: Vertical and horizontal clearances

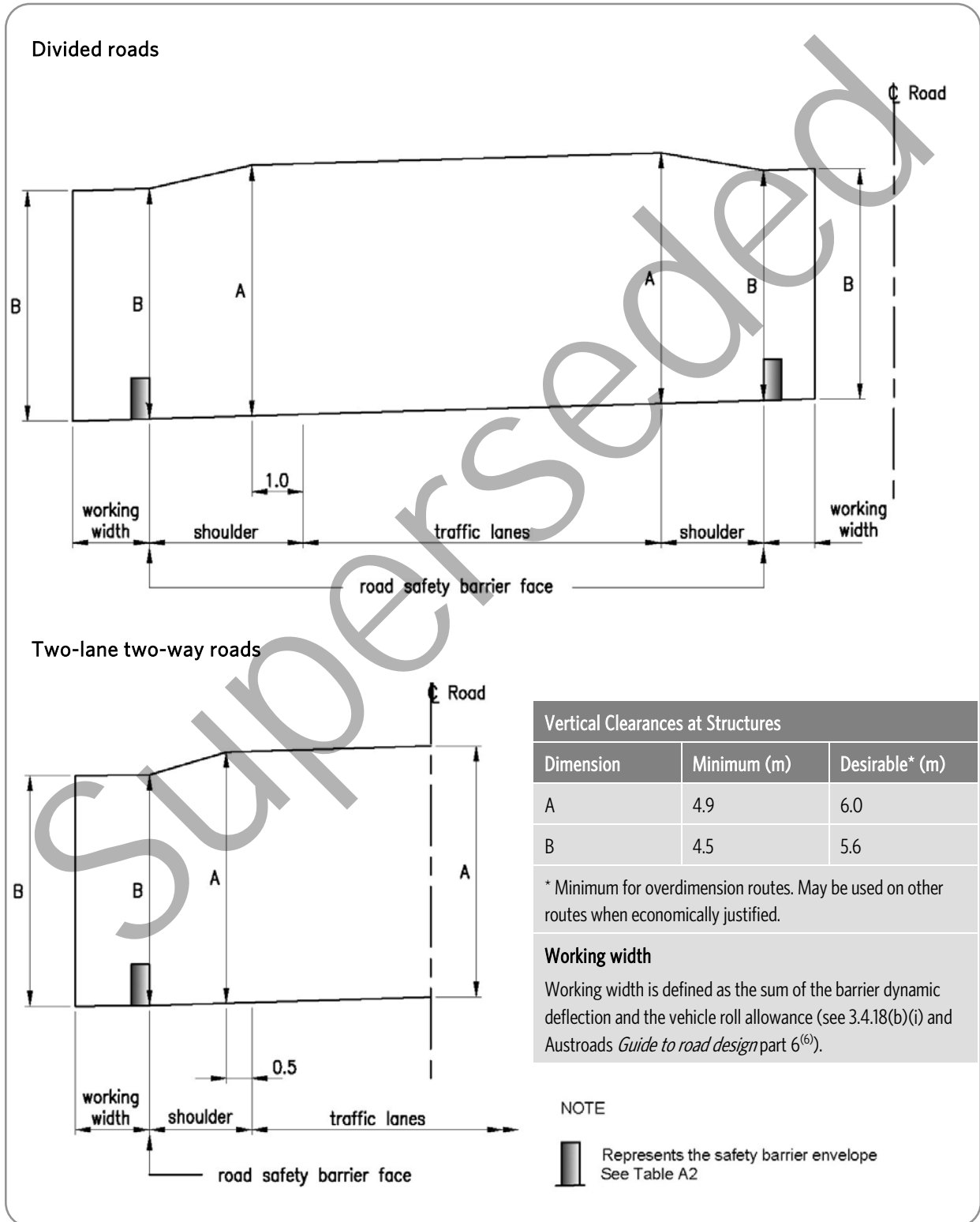

A3 continued

Notes to figure A4:

1. Where the NZTA has resolved that a state highway, or part of a state highway, is an overdimension load route, to allow for the passage of overdimension loads, all new structures crossing the route shall provide a minimum vertical clearance of 6.0m over a carriageway width of at least 10.0m. The effects of truck tracking on curves shall also be allowed for.
 2. All overhead clearances shall be measured vertically.
 3. Lateral clearances shall also be checked for sight distance on curved alignments.
 4. Overhead clearances to footpaths shall be as large as practical, but not less than 2.5m.
 5. Design vertical clearances given in figure A4 shall be increased where appropriate to make provision for settlement and road surfacing overlays. As a guideline, provide a minimum of 100mm more than the design vertical clearance where an overlay is anticipated.
 6. Where a barrier is not required, the working width dimension shall be replaced by a distance of 1.5m (urban) and 2.0m (rural).
 7. Vertical clearances at pedestrian bridges shall be:
 - a. At least 200mm greater than adjacent traffic bridges, but not less than 5.1 m.
 - b. At least 6.2m where there are no adjacent traffic bridges over the road crossed by the footbridge between the footbridge and roads or ramps intersecting the underlying road.
 8. For bridges over railway lines, Kivirail (the New Zealand Railways Corporation) shall be consulted on their requirements for any particular site location.
-

Superseded

A4 References

- (1) Austroads (2010) *Guide to road design*. Part 3 Geometric design, AGRD03-10. Sydney, NSW, Australia.
 - (2) Austroads (2014) *Austroads glossary of terms*, AP-C87-14. Sydney, NSW, Australia.
 - (3) Austroads (2009) *Guide to road design*. Part 6A Pedestrian and cyclist paths, AGRD06A-09. Sydney, NSW, Australia.
 - (4) Highways Agency (2005) TA 91/05 *Provision for non-motorised users*. TSO, London, United Kingdom.
 - (5) Highways Agency (2005) TA 90/05 *The geometric design of pedestrian, cycle and equestrian routes*. TSO, London, United Kingdom.
 - (6) Austroads (2010) *Guide to road design*. Part 6 Roadside design, safety and barriers, AGRD06-10. Sydney, NSW, Australia.
-

Superseded

Appendix B Barrier systems on structures

In this section

	Section	Page
B1	General	B-2
B2	Types of barrier system and their applications	B-2
B3	Barrier performance selection method	B-5
B4	Barrier acceptance criteria	B-10
B5	Standard solutions	B-11
B6	Side protection design criteria	B-11
B7	Geometric layout, end treatment and transitions - the NZTA's requirements	B-16
B8	Non-proprietary bridge barrier system	B-18
B9	References	B-22

B1 General

B1.1 General

This appendix provides guidance on types of barrier for traffic and vulnerable road users (ie pedestrians, cyclists and equestrians), their application and design and guidelines for determining appropriate barrier performance levels. The following topics are covered:

- B2 Types of barrier system and their applications
- B3 Barrier performance selection method
- B4 Barrier acceptance criteria
- B5 Standard traffic barrier solutions
- B6 Barrier system design criteria
- B7 Geometric layout (end treatment and transitions)

Median barriers on separated structures shall be treated as side protection.

B2 Types of barrier system and their applications

B2.1 General

The selection of an appropriate road safety barrier system for any structure is an important safety process. The level of protection should be not less than that provided at the roadside on the approaches to the structure and any hazard protected by that barrier. This level of protection should be applied to the 'length of need' required to adequately protect the hazard (*Austrroads Guide to road design Part 6 Roadside design, safety and barriers*⁽¹⁾).

The road safety barrier system shall consist of one of the alternatives detailed below for each situation except where a 'no barrier' solution is deemed acceptable in accordance with B3.1.6. The required road safety barrier performance level and subsequent barrier selection shall be appropriate to that required by any roadside hazard in the vicinity of the structure and take into account traffic (B3), pedestrian presence (B2.4), cyclist and equestrian presence (B2.5) and provision for the occasional presence of people (B2.9).

NZTA M23 *Specification for road safety barrier systems*⁽²⁾ covers road safety barrier systems accepted for installation on the state highway network.

Structures shall comply with the clause F4 *Safety from falling* requirements of the *Building code*⁽³⁾. Clause F4 requires barriers of "appropriate height" to be installed so that structures are "constructed to reduce the likelihood of accidental fall". This may include the provision of barriers specifically for pedestrians and other vulnerable road users.

B2.2 Semi-rigid barrier

A semi-rigid barrier is defined as a post and continuous rail system which restrains vehicles by absorbing energy during deformation of the system and of the vehicle.

B2.3 Rigid barrier

A rigid barrier is defined as a barrier designed so that there will be no movement of the barrier system, other than elastic straining during a crash involving the design vehicle. They include continuous concrete barriers and metal post and rail systems that behave in a rigid manner. Rigid barriers shall be used in preference to semi-rigid barriers in the following situations:

- i. For architectural consistency, where rigid barriers are used on the approaches.
- ii. Where it is necessary to provide additional protection for a particularly vulnerable structural element or sensitive hazard (TL-5 and greater).
- iii. Where deflection of a semi-rigid barrier system cannot be accommodated or is undesirable.

B2.4 Pedestrian barrier

A pedestrian barrier is defined as a post and rail system that restrains pedestrians. Pedestrian barriers may be of two types:

- General type, which consists of a series of posts supporting a top rail, below which is any system of members between which the spaces are not more than 300mm in at least one direction.
- Vertical bar type, which consists of a series of posts supporting a top rail, below which are vertical bars, between which the spaces are not more than 100mm. The vertical bars shall be attached only at the top and bottom.

Barriers of both types shall have a minimum height to the top edge of the top rail of 1100mm and shall comply with *New Zealand building code* acceptable solution F4/AS1⁽⁴⁾.

Pedestrian barriers shall not be used for the restraint of vehicles and should only be used in the following locations:

- on a structure provided for the sole use of pedestrians, ie not motorised traffic
- on the outside of a footpath on a structure that is separated from the motorised traffic by a semi-rigid barrier or a rigid barrier.

The vertical bar type shall be used in the following situations:

- i. In locations where children less than six years of age are expected to frequent the structure or on known or nominated school walking routes.
- ii. Where the structure crosses over or is above building properties, city streets, main highways, motorways, or railways.
- iii. Where the footpath is at a general height of more than 5m above ground or water level.
- iv. Where the volume of pedestrian traffic is exceptionally heavy or likely to become so.
- v. Where there are circumstances likely to cause alarm to pedestrians, such as a river prone to violent, rapid flooding, that demand a higher level of pedestrian protection be provided.

The general type may be used elsewhere.

B2.5 Cyclist and equestrian barriers

The principles described in B2.4 also apply to the protection of cyclists and equestrians, with barriers similarly only being used on dedicated structures or outside of paths on structures that are separated from motorised traffic by a semi-rigid barrier or a rigid barrier.

The minimum height to the top edge of the top rail for a cyclist barrier shall be 1400mm and for an equestrian barrier 1800mm. A 600mm high solid infill panel shall be provided at the bottom of an equestrian barrier to obstruct a horse's view of the void below.

Cyclist and equestrian barriers should be designed appropriately in accordance with B6.4. Unless specified otherwise, cyclist and equestrian barriers should also incorporate the relevant requirements for pedestrians as required by the B2.4.

B2.6 Combination barrier

A combination barrier shall satisfy the requirements for a traffic barrier and shall provide additional protection for vulnerable road users as required, typically through adding additional rails or increasing the traffic barrier height. This may be where extra provision for safety from falling is required or where significant pedestrian, cyclist or equestrian presence is anticipated.

Having established the level of protection to be provided for the hazards presented to traffic, consideration must be given to the additional protection required when there are significant numbers of vulnerable road users anticipated or specific facilities provided for them. Depending on the facility provided, the additional design requirements are in B6.

B2.6 continued	The provision of specific facilities for pedestrians, cyclists and equestrians within the bridge cross-section is covered by appendix A.
B2.7 Barrier kerb	<p>A barrier kerb is defined as a high kerb that protects pedestrians by restraining the wheels of vehicles. Historically, this type of kerb was typically used adjacent to a footpath and provided additional restraint to errant vehicles because the side protection on the bridge was inadequate.</p> <p>Barrier kerbs shall not be used on new structures. They may only be used on existing structures in exceptional circumstances with the agreement of the road controlling authority.</p>
B2.8 Barrier configurations for specific situations	<p>a. Traffic lane (with shoulder) adjacent to deck edge:</p> <ol style="list-style-type: none"> i. semi-rigid barrier ii. rigid barrier (eg concrete with or without top rail or metal post and rail). <p>b. Traffic lane (with shoulder) adjacent to footpath:</p> <ol style="list-style-type: none"> i. The use of a kerb between the carriageway and the footpath requires a semi-rigid or rigid barrier at the outer edge of the footpath. ii. Semi-rigid or rigid barrier between the carriageway and the footpath requires a pedestrian, cyclist or equestrian barrier at the outer edge of the footpath. <p>c. Separated (off-road) footpath, cycle path or bridle path:</p> <ol style="list-style-type: none"> i. Semi-rigid barrier or combination barrier between the carriageway and the footpath requires a pedestrian/cyclist/equestrian barrier at the outer edge of the footpath. ii. Rigid barrier (with or without additional rail) between the carriageway and the footpath requires a pedestrian/cyclist/equestrian barrier at the outer edge of the footpath. <p>The standard cross-sections shown in figure A1 illustrate various possible combinations of these alternatives.</p>
B2.9 Provision for the occasional presence of people	<p>Where no specific footpath or barrier provisions for vulnerable road users are provided on a structure, barriers with a minimum height to the top edge of the top rail of 900mm shall be provided unless:</p> <ul style="list-style-type: none"> • a 'no barrier' solution is deemed acceptable in accordance with B3.1.6 • barriers are otherwise agreed to not be required by the road controlling authority • a risk assessment determines that alternative lower height barrier provisions are appropriate as the likely number of vulnerable road users on the structure is very low or the hazard being protected is of low risk • a risk assessment determines that higher height barrier provisions are required. <p>These barriers are to allow for the presence of road users such as inspection, maintenance and emergency personnel and pedestrians in a remote rural environment, termed as allowing for the "occasional presence of people" for the purposes of this clause.</p> <p>Any risk assessment undertaken shall take due consideration of the requirements of the clause F4 <i>Safety from falling</i> requirements of the <i>Building code</i>⁽³⁾ and the MBIE <i>Best practice guidelines for working at height in New Zealand</i>⁽⁵⁾ and shall be presented for agreement by the road controlling authority in the structure options report and structure design statement as details are developed.</p> <p>Traffic safety barriers or combination barriers are considered acceptable provision for the occasional presence of people. The use of modified Thrie Beam barrier (865mm high), as detailed in table B2, is also generally considered acceptable.</p>

B3 Barrier performance selection method

A risk assessment approach shall be used to indicate the likely traffic barrier performance level required at a structure site. This assessment must consider both the structure and the associated approaches.

The NCHRP Report 350 *Recommended procedures for the safety performance evaluation of highway features*⁽⁶⁾ test level corresponding to each barrier performance level is presented in table B1.

Table B1: Barrier performance levels and equivalent NCHRP Report 350⁽⁶⁾ test levels

Barrier performance level	Equivalent NCHRP Report 350 ⁽⁶⁾ test level
Special	No equivalent test
6	TL-6
5	TL-5
4	TL-4
3	TL-3

This risk assessment approach applies to barriers for new structures and replacement barriers for existing structures. It provides a barrier selection method based on a risk approach that encompasses traffic conditions and the structure environment.

This method focuses on the exposure to the risk, ie traffic volume, rather than the severity of outcome. Therefore B3.1 also provides specific criteria for the selection of an appropriate barrier performance level based on severity of outcome.

Figure B1 is to be followed for the selection of an appropriate barrier at a particular structure location.

B3.1 Performance levels

B3.1.1 General

The performance of the edge protection (barrier) system should be commensurate with the object being protected from the traffic or that the traffic is being prevented from hitting. The philosophy applied to assess the performance level should be consistent with that applied to the adjacent highway network.

There are five test levels available to the designer depending on the context of the structure. These range from the minimum TL-3 (not usually allowable on new state highway structures) to a 'special performance' barrier designed to protect a specific hazard and vehicle.

The following sections describe the context requiring each level of protection. Designers should start with the conditions requiring TL-5 and then work through to TL-3 as necessary. Should the requirements for a TL-5 barrier be exceeded (B3.1.2) then a full risk assessment should be carried out as part of the selection of a TL-6 or 'special performance' barrier system.

The requirements for the occasional presence of people given in B2.9 should be noted.

B3.1.2 Barrier performance level 5

A barrier performance level 5 barrier shall be the standard side protection barrier for structures carrying a divided multi-lane state highway.

B3.1 continued

A barrier performance level 5 barrier provides for the containment of buses and medium mass vehicles on high speed carriageways, major carriageways, and urban roads with a medium to high level of mixed heavy vehicles, and site specific risk situations.

A barrier performance level 5 barrier system shall be provided as edge protection for a structure where the number of commercial vehicles passing over the structure exceeds either of the following values:

- a. on roads with a posted speed limit greater than 60km/h: 2000 heavy commercial vehicles per day, or
- b. on roads with a posted speed limit of 60km/h or less: 4000 heavy commercial vehicles per day.

A barrier performance level 5 barrier system shall be provided as edge protection for a structure where one or more of the following conditions exist on the road or hazard being spanned by the structure:

- c. major roads with AADT (annual average daily traffic) of 10,000 or more vehicles per day (vpd)/lane, or
- d. roads with AADT of 40,000 or more vpd, or
- e. electrified railways, or over goods lines carrying significant quantities of either noxious or flammable substances, or
- f. high occupancy land such as houses, factories, areas for congregating, etc.
- g. the height differential is more than 10 metres
- h. water depth is greater than 3 metres
- i. the highway crossing the structure is on a horizontal curve with a radius of 600m or less.

The AADT referred to above is the estimated construction year AADT (refer to B3.2 for further explanation of this). Refer B3.2.3 for heavy commercial vehicle definitions.

Consideration should only be given to use of a higher performance level barrier if the conditions detailed in B3.1.5 apply.

B3.1.3 Barrier performance level 4

A barrier performance level 4 barrier provides for the appropriate containment of cars, heavy utilities and light to medium mass commercial vehicles on main (single lane) carriageways.

This is the minimum standard acceptable for all new state highway structures unless site specific acceptance is obtained from the National Manager Traffic & Safety.

B3.1.4 Barrier performance level 3

A barrier performance level 3 barrier provides for the safe containment of light vehicles, with occasional use by medium-heavy commercial vehicles, such as stock trucks and/or farm equipment.

These barriers should generally be considered for use on structures on non-state highway rural roads:

- a. with low traffic volumes (typically less than 500vpd) and in low speed environments (70km/h or less); or
- b. short structures (<10m) with low height above ground (<1.5m), or across shallow water (<1.0m).

B3.1 continued

B3.1.5 Special barrier performance level (test level 6 and above)

1. Barrier performance level 6

A barrier performance level 6 barrier shall only be provided at specific locations where agreed by the road controlling authority, where there is a high probability of loss of life or serious injury due to a vehicle penetrating the barrier.

A barrier performance level 6 barrier shall be only be considered if the commercial traffic volume criteria detailed for barrier performance level 5 (refer B3.1.2(a) and (b)) are expected to be exceeded for sustained periods and any of the crossed environment or height conditions stated in B3.1.2(c) to (i) apply, subject to an appropriate risk and benefit-cost analysis justification to the *NZTA Economic evaluation manual*⁽⁷⁾.

2. Special barrier performance

A special performance level, non-penetrable barrier shall only be provided at specific locations where agreed by the road controlling authority, where vaulting by high mass and high centre of gravity vehicles must be prevented.

Such a barrier shall be considered if the commercial traffic volume criteria detailed for barrier performance level 5 (refer B3.1.2(a) and (b)) are expected to be exceeded for sustained periods and at least two of the crossed environment or height conditions stated in B3.1.2(c) to (i) apply at the same time, subject to benefit-cost justification.

There is no equivalent NCHRP Report 350⁽⁶⁾ test level for this performance level. A 44t articulated heavy commercial vehicle (HCV) shall be the controlling vehicle in determining barrier strength with the remaining test requirements as per TL-6 (NCHRP Report 350⁽⁶⁾).

B3.1.6 'No barrier' option

For certain structure sites, conditions may be such that the presence of a barrier constitutes a risk that is higher than or similar to the hazard being protected. Consideration may therefore be given to omitting barriers where all the following conditions are satisfied (noting that the requirements of the *Building code*⁽³⁾, to safeguard people from injury caused by falling, can be complied with even if no barrier is provided):

- there are no barriers on the approaches to the structure
- conditions under and near the structure do not increase the level of risk to the occupants of the vehicle leaving the structure
- the edge of the structure is less than 1.5m above the ground
- water beneath the structure is less than 1m deep
- traffic volumes are less than 150 vehicles per day
- the radius of curvature at the structure site is greater than 1500m and the road approaches have visibility greater than the required stopping sight distance
- the location is rural and without provision for pedestrian traffic
- the bridge or structure is less than 5m long in the direction of travel and the deck extends at least 1.2m laterally beyond the carriageway edge.

When the edge of the structure is greater than 9 metres from the edge of the carriageway, or when a culvert is less than 3.4m² and has ends flush with the embankment slope, a risk assessment should be carried out in accordance with the *Austrroads Guide to road design* part 6⁽¹⁾.

B3.1 continued

Where a 'no barrier' option is proposed, details shall be presented for agreement by the road controlling authority in the structure options report and structure design statement as details are developed.

**B3.2 Adjusted
AADT method for
barrier performance
levels 3, 4 and 5
selection**

B3.2.1 General

Once it has been determined that a barrier is required, if the context of the structure does not require a barrier performance level 5 or 6, or a special performance barrier, the appropriate performance level shall also be assessed using the adjusted AADT method outlined in AS 5100.1 *Bridge design* part 1 Scope and general principles⁽⁸⁾ section B4, with modifications detailed in this manual to account for New Zealand conditions, and as indicated in figure B1. This method assumes 2% traffic growth per annum over 30 years.

Where there is a difference between the test level determined using B3.1 and this 'Adjusted AADT method', the greater of the two test levels should be adopted.

The adjusted AADT method shall be used as follows:

- i. If the estimated traffic growth is 2% per annum then AS 5100.1⁽⁸⁾ section B4 with the following amendments can be used directly.
- ii. For growth rates other than 2% per annum the construction year AADT for use in this section can be estimated by dividing the 30-year after construction AADT by 1.81. The error in using this estimation is acceptable and within the assumptions of this methodology.

The adjusted AADT shall be calculated as follows:

$$\text{Adjusted AADT} = RT \times GD \times CU \times US \times \text{AADT}$$

Where: RT = Road type factor (from AS 5100.1⁽⁸⁾ table B1).

GD = Road grade factor (from AS 5100.1⁽⁸⁾ figure B2).

CU = Curvature factor (from figure B2 of this manual).

For radius of curvature less than 600m refer to section B3.1.2 of this manual.

US = Deck height and under-structure conditions factor (from AS 5100.1⁽⁸⁾ figure B4) for the risks described in AS 5100.1⁽⁸⁾ section B4.2.5.

AADT = AADT in construction year

The AADT is the total traffic volume for all lanes in both directions crossing the structure.

B3.2.2 Final barrier performance level selection

The final barrier performance level is selected by comparing the adjusted AADT with the threshold limits for the appropriate design speed given in AS 5100.1⁽⁸⁾ figures B5 to B8.

These threshold graphs also include an additional variable to cater for the offset from the face of the barrier to the edge of the traffic lane, described as rail offset in the charts.

Note that a 'rail offset' of 0.3m shall be assumed in all instances for the purposes of this clause.

The barrier performance levels described in AS 5100.1⁽⁸⁾ figures B5 to B8 shall be substituted as follows:

- Replace "Medium Level" by "Barrier performance level 5"
- Replace "Regular Level" by "Barrier performance level 4"
- Replace "Low Level" by "Barrier performance level 3".

Figure B1: Traffic barrier performance selection flow chart

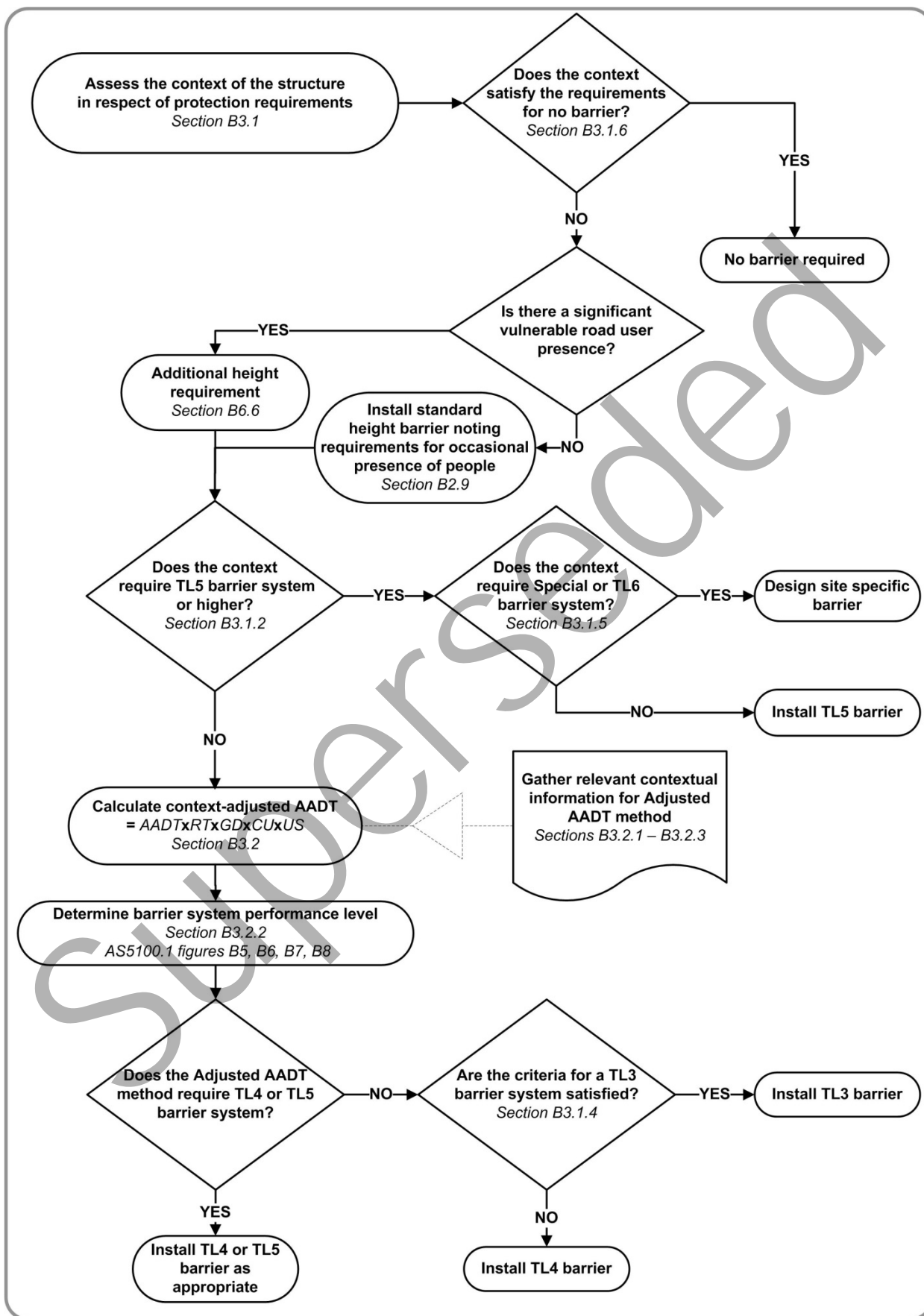

B3.2 continued

B3.2.3 Vehicles and traffic mix

The percentage of commercial vehicles in AS 5100.1⁽⁸⁾ figures B5 to B8 includes medium to heavy commercial vehicles (ie MCV to HC VII as described in the NZTA's *Economic evaluation manual*⁽⁷⁾).

For locations where the commercial vehicle (MCV to HC VII) traffic mix exceeds 40% the designer shall determine the appropriate barrier performance level based on a site-specific benefit-cost analysis. The performance level selected shall not be less than that required by these charts.

Figure B2: Curvature factor

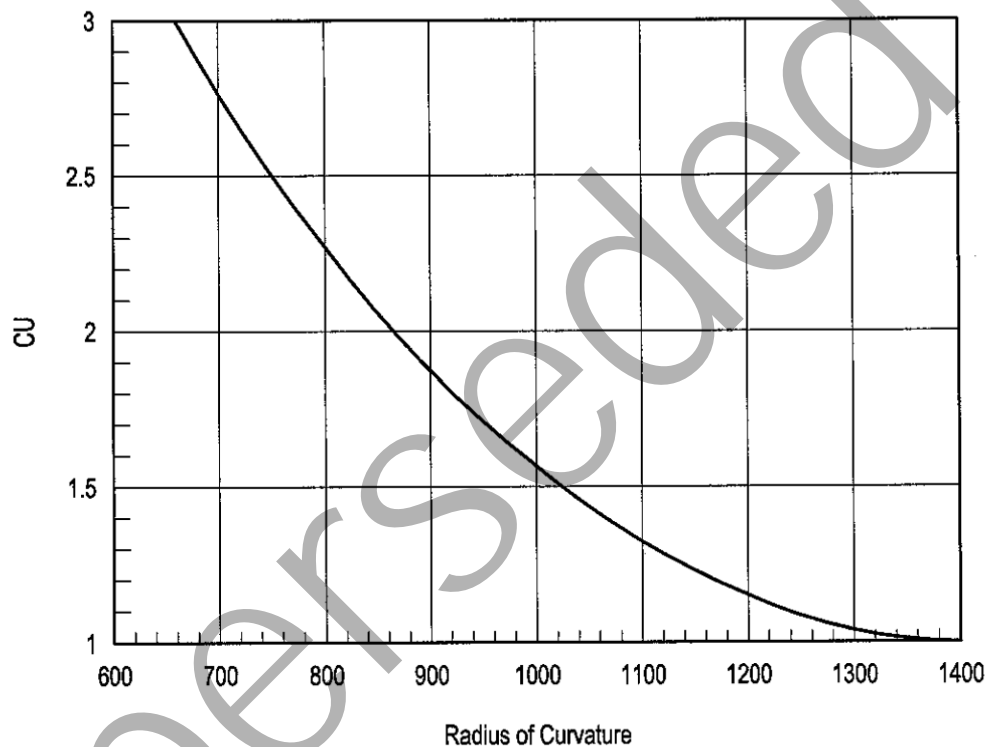

B4 Barrier acceptance criteria

Only barriers that comply with one of the following criteria shall be used for side protection on structures:

- a. The barrier system is listed in NZTA M23⁽²⁾, ie has undergone satisfactory crash testing to the appropriate test level in accordance with NCHRP Report 350⁽⁶⁾ or higher, and has been accepted for installation in New Zealand.
- b. The barrier system is based on similar crash tested barriers used elsewhere subject to formal acceptance by the road controlling authority.
- c. The barrier system is a variation of B4(a) or B4(b) and has been 'deemed to comply' by the NZTA.

Crash testing/performance of the proposed barrier shall be to the appropriate level as determined in B3.

B5 Standard solutions

Table B2 gives standard non-proprietary solutions that meet the performance levels indicated. Equivalent lateral forces for each performance level are given in section B6 for design of the supporting structure and reinforcement for continuous rigid concrete barrier systems, where the profile has been accepted for the appropriate performance level. The standard solutions listed are not intended to be a complete list of acceptable solutions. The designer may specify alternative barrier systems subject to the acceptance criteria of section B4 and elsewhere in this manual.

Table B2: Standard non-proprietary solutions

Barrier performance level	NCHRP Report 350 ⁽⁶⁾ test level	Accepted barrier types	Reference
3	TL-3	W-beam guardrail (2.7mm thick, grade 350MPa steel), posts at 1.905m centres Rails may be added to this barrier to provide a combination barrier on non-state highways (see B6.6)	NZTA M23 ⁽²⁾ appendix B.
4	TL-4	a. Modified Thrie-beam with modified I section blockout and posts, posts at 2.0m centres, 865mm high Rails may be added to this barrier to provide a combination barrier (see B6.6) b. Monolithic 'F' shape concrete barrier 915mm high	AS/NZS 3845 ⁽⁹⁾ NZTA M23 ⁽²⁾ appendix B
5	TL-5	a. HT 'F' shape barrier. This is the TL-5 barrier preferred by the NZTA and may be used as a combination barrier (see B6.6) b. Monolithic 'F' shape concrete barrier 1070mm high	NZTA M23 ⁽²⁾ appendix B NZTA M23 ⁽²⁾ appendix B
6	TL-6	Any FHWA TL-6 approved system, subject to the road controlling authority's acceptance	FHWA website ⁽¹⁰⁾
SPECIAL	Requires specific design		

Note:

820 high VCB barrier to the profile shown in AS/NZS 3845⁽⁹⁾ figure 3.12(6) and with reinforcement determined using the equivalent lateral forces in B6, may be used on non-state highways where there is a permanent posted speed limit of 50km/h or less with the acceptance of the road controlling authority. The requirements for the occasional presence of people given in B2.9 should be noted.

B6 Side protection design criteria

B6.1 Equivalent lateral loads and height of application for rigid traffic barriers

Where a rigid barrier system other than those listed in NZTA M23⁽²⁾ is proposed, the loads in table B3 shall be used to determine structural requirements such as the reinforcement required in continuous rigid concrete barriers where the profile has been accepted for the appropriate performance level. These loads shall be treated as ultimate limit state loads and no further load factor need be applied to them. The transverse and longitudinal loads shall be applied at height H_e . The load F_v shall be applied along the top of the barrier as indicated in figure B3. All loads shall be applied to the longitudinal barrier elements.

Design of reinforcement for rigid concrete barriers using the loads in table B3 requires detailed analysis. Loads should be applied uniformly over the specified contact lengths. Design of rigid concrete barriers shall be carried out in accordance with 4.2 of this manual.

B6.1 continued

Rigid barrier reinforcement details provided in section 3 of AS/NZS 3845 *Road safety barrier systems*⁽⁹⁾ shall not be used.

Table B3: Rigid barrier design ULS loads, contact lengths and effective heights

Barrier performance level	Transverse outward load F_t (kN)	Longitudinal load F_L (kN)	Transverse and longitudinal vehicle contact lengths L_t and L_L (m)	Vertical down load F_V (kN)	Vehicle contact length for vertical loads L_V (m)	Minimum effective barrier height H_e (mm)
4	250	80	1.1	80	5.5	800
5	500	170	2.4	355	12	1100
6	780	260	2.4	355	12	1400
SPECIAL	1000	330	2.5	380	15	1700 to 2000

The following load combinations shall be considered when using the loads in table B3 for the design of the barrier:

- i. transverse and longitudinal loads acting simultaneously
- ii. vertical loads only.

Either the transverse or longitudinal load shall be considered as acting concurrently with the vertical load for the design of the deck slab and supporting structure, whichever is critical.

The effective height of a barrier is the height of the resultant of the lateral resistance forces of the individual components of the barrier above the surface of the carriageway. Barriers must have sufficient height to ensure that the minimum effective heights quoted above are achieved. Actual heights of rigid concrete barriers may be marginally higher than the required effective height.

Figure B3: Barrier design forces

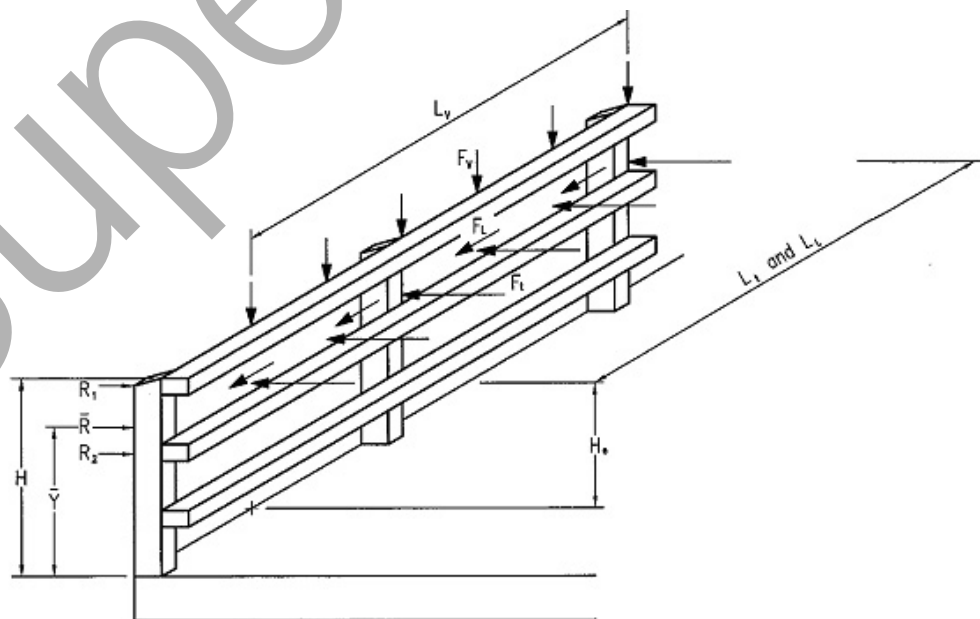

'H' is the height of barrier from the level of the adjacent deck, footpath or verge to the top of the barrier.

B6.2 Equivalent lateral loads and height of application for semi-rigid traffic barriers

Where a semi-rigid barrier system other than those listed in NZTA M23⁽²⁾ is proposed, the loads in table B4 shall be used to determine the structural requirements. These loads shall be treated as ultimate limit state loads and no further factor need be applied to them. The transverse (outward and inward) and longitudinal loads shall be applied at height H_e . All loads shall be applied to the barrier elements. In general the longitudinal load F_L will set the rail type and thickness required for the adopted barrier performance level. Construction of the adopted rail system shall ensure the full strength is available.

Where a semi-rigid barrier system is positioned on a single lane bridge then the transverse loads can be taken as 67% of those specified in table B4.

Semi-rigid barrier design shall assume use of a mechanical fuse to limit deck and superstructure loadings with the barrier system reliant on the longitudinal tension developing in the rail to provide errant vehicle re-direction. Rail anchorage requirements as set out in table B4 must be met to ensure the rail longitudinal tension develops. Barrier design must also ensure appropriate transitions are provided between the barrier on the structure and the connecting approach barrier.

Full capacity 'button head' high strength bolt fixings shall be provided at all rail to post and blackout connections. Quick release fixings shall not be used.

Table B4: Semi-rigid barrier design criteria (assuming the barrier has a minimum lateral offset to the deck edge of 0.5m)

Barrier performance level	Minimum transverse outward load ¹	Minimum transverse inward load ²	Number of posts fully loaded in the design collision ³	Expected longitudinal barrier load in the design collision ⁴	Minimum longitudinal barrier anchorage load ⁵	Barrier centreline height ⁶
	F_{to} (kN)	F_{ti} (kN)		F_L (kN)	F_{LA} (kN)	H_e (mm)
3	45	19	3	500	450	550
4	60	24	5	900	750	620

Notes:

1. Transverse outward load is to be applied to determine the post or its fixing fragility under the typical errant vehicle collision. The load level is set to optimise energy absorption and control ongoing collision maintenance.
2. Transverse inward load is to be applied to determine the post or its fixing fragility under an errant vehicle snagging collision. The load level is set to optimise energy absorption and control ongoing collision maintenance.
3. For ultimate limit state design of the supporting bridge deck and superstructure, retaining wall or foundation the specified number of posts shall be fully loaded for the transverse outward or inward loads for the case under consideration.
4. The minimum F_L specified shall be used to confirm rail longitudinal strength and minimum connectivity.
5. The minimum F_{LA} specified shall be provided to ensure the rail barrier re-directs the errant vehicle within the allowable lateral displacement. With the use of standard cross braced cable bays a nominal 150kN tension per bay is achieved, hence the minimum anchorage specified is equivalent to 3 bays and 5 bays respectively for the two barrier performance levels. Barrier rail anchorage set out shall meet the layout detailed in NZTA M23⁽²⁾ appendix B for non-proprietary systems. In general the typical anchor spacing on straight structures shall not exceed 80m. For curved structures (>250m radius) the anchor spacing along the outside edge of the curve may be set at 100m whereas the anchor spacing along the inside edge of the curve shall not exceed 60m. Anchor spacing for structures on small radius curves shall be subject to specific design.
6. The barrier transverse and longitudinal loads shall be applied at the specified barrier centreline height, as measured from the top of the road surface at the face of the barrier. Barrier set out shall include allowance for the road surfacing strategy at the site.

B6.3 Design of deck slabs and retaining walls to resist barrier forces

Design of a deck slab shall be such that any failure is confined to the barrier and that the fixings to the deck, the deck slab and supporting structure are not damaged during failure of the barrier, except where holding down bolts are specifically designed to break away in semi-rigid barrier applications or starter bars are designed to yield for rigid barriers.

The design of a retaining wall where a barrier is on top shall be similarly undertaken such that failure is confined to the barrier. Load distribution from the barrier into the retaining wall, either integral with the retaining wall or with separate foundations at the top of the retaining wall, may be considered in accordance with figure 6 of *Design criteria of standard earth retaining systems*⁽¹¹⁾.

- a. For rigid barrier systems, the equivalent ultimate limit state forces and contact lengths set out in table B3 shall be used for the calculation of forces in the deck, retaining wall or foundation for the required performance level. The deck, wall or foundation capacity shall be sufficient to resist overstrength actions generated by the barrier capacity, when the loads set out in table B3 are applied. Characteristic strengths and capacity reduction factors of $\phi=1.0$ for flexure and $\phi=0.85$ for shear shall be used for the design of the deck, wall or foundation capacity.

When barrier collision occurs the overstrength capacity collision load actions shall be combined with an HN vehicle positioned at the barrier face. This vehicle load may be considered as an overload (OL) for the determination of load factors.

- b. For semi-rigid barrier systems, the deck slab, retaining wall or foundation shall be designed to withstand the forces mobilised by the yielding components of the barrier post (ie either the post fixings or post base acting in flexure or shear) developing their overstrength capacity.

Deck slab and foundation design shall consider two collision load cases, whilst retaining wall design need only consider the first collision load case:

- i. When barrier collision just occurs the post or base plate overstrength capacity collision load actions shall be combined with an HN vehicle positioned at the rail barrier face.
- ii. After barrier collision when the HN vehicle shall be positioned at the deck or foundation edge to generate the most adverse actions. It is assumed the barrier has 'knocked-off' and no collision load need be applied in this case.

In both instances the vehicle load may be considered as an overload (OL) for the determination of load factors.

B6.4 Pedestrian, cyclist and equestrian barriers

Pedestrian, cyclist and equestrian barriers shall be designed for the most extreme of the following loads:

- a. horizontal and vertical service loads of 1.75kN/m applied to the top rail
- b. a horizontal service load of 1.5kN/m² applied to the gross area of the barrier
- c. a point load of 0.5kN in any direction at any point.

Horizontal and vertical loads need not act concurrently.

In addition to the provisions above, where the road controlling authority requires the barrier to restrain crowds or people under panic conditions, the barrier shall be designed for the most extreme of the following loads:

- a. a horizontal service load of 3.0kN/m acting away from the path simultaneously with a vertical service load of 0.75kN/m acting on the top rail

B6.4 continued

- b. a horizontal service load of 1.5kN/m simultaneously with a vertical service load of 0.75kN/m acting on any one longitudinal member
- c. a horizontal service load of 1.5kN/m² applied to the gross area of the barrier
- d. a horizontal point load of 1.0kN acting away from the path at any point.

The load factor for the ultimate limit state shall be 1.8 for design of the barrier, fixings and supporting structure.

Note that for cyclist and equestrian barriers the loads to the top rails are applied at a height greater than the maximum required under *New Zealand building code* verification method B1/VM1⁽¹²⁾.

Consideration shall be given to the provision of a separate handrail in situations where clause D1 *Access routes* of the *Building code*⁽³⁾ is applicable.

The barrier shall present a smooth surface without snagging points. A fundamental principle in designing barrier protection for cyclists is that the first point of contact between a cyclist and the barrier should be the cyclist's forearm with the barrier top rail.

Pedestrian, cyclist and equestrian barriers shall also satisfy the following criteria:

- a. Rails shall be round or possess round corners to minimise the potential for injury to users of the structure, particularly cyclists, toppling into them.
- b. Supports shall be installed to minimise the potential for snagging of cycle handlebars or pedals. The *Austrroads Guide to road design* part 6A *Pedestrian and cyclist paths*⁽¹³⁾, indicates there should be a 150mm pedal clearance from top rail to post on full barriers.
- c. They shall extend sufficiently beyond the ends of the structure to satisfy the requirements of the *Building code*⁽³⁾.

B6.5 Equestrian barriers

Not used. See B2.5 and B6.4.

B6.6 Combination barriers (traffic and pedestrian/cyclist/equestrian)

Combination barriers shall be designed to resist the forces appropriate to the barrier performance level required from B6.1 or B6.2. Pedestrian/ cyclist portions of combination barriers shall resist loads of 4.4kN/m horizontally and 1.75kN/m vertically, applied to the top rail. Other members shall resist, as a minimum, the loads described in B6.4. The load factor for these pedestrian/cyclist loads for the ultimate limit state shall be 1.8.

Rails to combination barriers shall also satisfy the following criteria:

- Rails shall be round or possess round corners to minimise the potential for injury to cyclists toppling into them.
- Supports for the rails shall be installed to minimise the potential for the snagging of cycle handlebars.
- Barrier rails shall be positively interconnected at expansion joints in the rails with a connection of sufficient strength to prevent the rails separating under vehicle impact and spearing the impacting vehicle. The capacity of the rail-barrier connection shall be sufficient to support the rail from collapsing off the structure following an impact.
- Rails shall extend sufficiently beyond the ends of the structure to satisfy the requirements of the *Building code*⁽³⁾ and then be deflected downwards and anchored.
- Intermediate rails shall be provided such that any clear gaps between rails and barrier comply with the *New Zealand building code* acceptable solution F4/AS1⁽⁴⁾.

- B6.6 continued**
- Whilst, for the safety of cyclists, the minimum height to the top edge of the top rail is generally 1400mm, the use of an HT 'F' shape barrier (1270mm high), as detailed in table B2, is generally considered acceptable for cyclist protection. An exception to this is when the cyclists are accommodated on a path outside of the barrier, when an additional top rail on the path side of the barrier may be provided at 1400mm height.
 - Systems that have not undergone crash testing require acceptance from the road controlling authority as a deemed to comply system.
 - The front face of the rails shall be set back from the vertical plane of the barrier face to minimise vehicle impact on the rails, unless the rail is a structural element of the barrier system.
 - The design of any top rails to a concrete barrier, including the fixings, shall ensure that the rail system fails in a ductile manner.

B6.7 Debris screening

Debris screening shall be incorporated into side protection barriers on structures where debris falling through such barriers could create a hazard to motorists on adjacent carriageways or carriageways beneath the structure or to adjacent land users.

Where debris screening is required for a structure carrying traffic over another carriageway or running immediately adjacent to, and at a higher level than, another carriageway, the edge protection system used shall provide a solid screen to a minimum height of 400mm above the higher carriageway to prevent debris falling onto the carriageway below.

If this screen is not provided by the side protection system itself, then a separate screen shall be provided on the external face of the barrier to satisfy this requirement.

Similarly, where debris screening is required for a structure carrying pedestrians or cyclists over a highway, a solid screen to a minimum height of 100mm above the path shall be provided. A kerb will satisfy this requirement.

Consideration must also be given to the provision of anti-throw screening to prevent objects being thrown onto the carriageway below, in particular bridges with provision for pedestrians over urban motorways. This should be done on an exposure/outcome basis and take into account the composition of the bridge users and the obstacle being spanned.

Where anti-throw screens are required they shall meet the minimum provisions of AS 5100.1⁽⁸⁾ clause 12.3.

B7 Geometric layout, end treatment and transitions - the NZTA's requirements

B7.1 General

Accepted barrier systems, end terminals and transitions are detailed in NZTA M23⁽²⁾ and the accompanying appendices.

B7.2 Rigid barrier

Rigid barriers shall generally be orientated vertically in the transverse direction. If the crossfall is less than 5% it may be more appropriate to rotate the barrier so that its axis is perpendicular to the road surface, as shown in figure 6.17 of the Austroads *Guide to road design* part 6⁽¹⁾.

B7.3 Semi-rigid barrier

Installation of proprietary semi-rigid barrier systems shall be in accordance with the manufacturer's instructions for the performance level prescribed.

B7.3 continued	<p>Unless specified otherwise in manufacturer's instructions or NZTA M23⁽²⁾, posts shall be erected normal to the road surface in the longitudinal direction, but vertical in the transverse direction.</p> <p>Holding down bolts shall be specifically designed to be easily removed and replaced after failure or damage.</p>
B7.4 Structure approaches	<p>The protection level provided by the barrier on the approaches to the structure shall be appropriate for the hazard at the structure. Where the protection level on the approach is less than that provided on the structure, the length of approach transition shall be assessed as the appropriate length of need for the hazard (<i>Austroads Guide to road design</i> part 6⁽¹⁾).</p> <p>A smooth continuous tensile face shall be maintained along the transition. Any exposed rail ends, posts or sharp changes in barrier component geometry shall be avoided, or sloped outwards or downwards with a minimum flare of 1 in 30 for barrier components and kerb discontinuities.</p> <p>Standard transition details are given in NZTA M23⁽²⁾ appendix A. Flexible (wire rope) barrier systems are not acceptable for edge protection on structure approaches as these are difficult to transition to semi-rigid and rigid systems.</p>
B7.5 End treatment	<p>The ends of a barrier shall have a crashworthy configuration or be shielded by a crashworthy barrier or impact attenuation device.</p> <p>Acceptable end terminals are detailed in NZTA M23⁽²⁾ appendix A.</p>
B7.6 Kerb	<p>Notwithstanding the requirement to maintain the approach road cross-section across the bridge, where the width between approach kerbs is different from that on the bridge, the horizontal transition between the two shall be an 'S-curve' such that the overall taper rate (rate of lateral shift) is not less than 0.6m/s of travel time at the design speed.</p> <p>For example; a 300mm change in width in a 50km/h speed environment would transition over a distance of $0.3 \times 13.9 / 0.6 = 7.0\text{m}$.</p> <p>Where the profile of the kerb on the bridge differs from that on the approach the transition between the approach kerb profile and that over the bridge should occur over a distance of between 2m and 5m (depending upon the extent of the change) and must not present an opportunity to either snag or launch an errant vehicle.</p>
B7.7 Barrier layout	<p>The geometric layout for the barrier on the approach to single and two-lane bridges shall comprise the appropriate performance level for the length of need required to protect the hazard, together with the appropriate transition sections between barriers of different test levels. The length of need shall be calculated in accordance with the <i>Austroads Guide to road design</i> part 6⁽¹⁾. (An example calculation is given in appendix I of the guide.) In New Zealand, the 'Angle of departure' method is preferred.</p>

B8 Non-proprietary bridge barrier system

B8.1 General

Details of a non-proprietary semi-rigid bridge barrier system that is suitable for use on state highway bridges, are given in NZTA M23⁽²⁾ appendix B.

The principle of operation of this system is shown in figure B4. It should be noted that, in this design, the use of holding down bolts with a specific minimum and maximum strength is essential. Deck slab details near to barrier posts for this system are shown in figure B5.

Figure B4: Semi-rigid barrier displacement and local post failure at impact

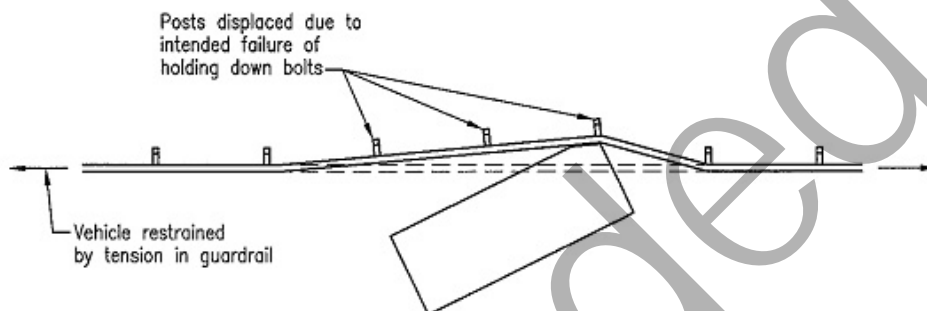

B8.2 Length changes and anchorages

a. Bridge length changes

No free longitudinal movement shall take place in joints between lengths of guardrail.

The guardrail is assumed to be fixed in space between its end anchors, while the bridge deck (and the guardrail posts) move relative to the guardrail as a result of temperature, shrinkage and creep effects. Provision shall be made in the guardrail at each post connection to enable relative movement to occur at this location. It is also assumed that longitudinal forces due to temperature changes can be resisted by the guardrail. Guardrail expansion joints shall be used only on bridges where long lengths of continuous superstructure between deck expansion joints give length changes that cannot be accommodated within the normal post expansion provision. Where the distance from a guardrail anchor point to the nearest deck expansion joint, exceeds 100m then an expansion joint is to be provided in the guardrail itself.

The expansion joint shall enable slow movements to take place without restraint, but act as a rigid connection under impact loading. Expansion joints or other devices which use rubber components to absorb movement shall not be used.

b. Guardrail anchors

Unless linked to highway guardrails on the approaches, a bridge guardrail shall be provided with end anchors capable of resisting its specified ultimate load. A bridge guardrail more than 150m long shall be provided with intermediate anchors as described below, capable of resisting the same load. The following types of anchors shall be used in the situations described:

i. Buried anchor

Where the approach to a bridge is in soft rock or a soil cutting the anchor to an approach guardrail should, if possible, be buried. Soil covering the anchor shall be well compacted. Details of a standard NZTA buried anchor are shown in NZTA M23⁽²⁾ appendix A.

B8.2 continued

ii. End treatment

Refer to B7.5.

iii. Intermediate anchor on a bridge

The anchor posts shall be designed to break away from the deck at their bases in the event of direct vehicle impact. When this occurs, restraint of the guardrail ribbon is provided by the adjacent anchors.

Details of a standard NZTA intermediate anchor are shown in NZTA M23⁽²⁾ appendix B.

c. Location of anchors

Guardrail anchor location requirements are as follows (they are shown diagrammatically in figure B6):

- The maximum distance between adjacent anchors shall be 150m.
- The maximum length over three consecutive anchors shall be 200m.
- Intermediate anchors shall be located at neutral points. Neutral points are defined as points on the bridge length which do not move longitudinally with length changes. If this is not possible, due to location of two or more anchors between consecutive expansion joints, the effect of the movement of the anchors relative to the guardrail due to creep and shrinkage shall be taken into account in the design by providing for adjustments in the anchor cable connections.
- If there is a high proportion of very heavy traffic and/or severe curvature, consideration should be given to providing guardrail anchors at every neutral point.
- End anchors shall be located at the appropriate distance from the bridge abutment or ends of a structure to satisfy the length of need required to protect the hazard.

Figure B5: Non-proprietary bridge barrier system – deck slab details near guardrail posts

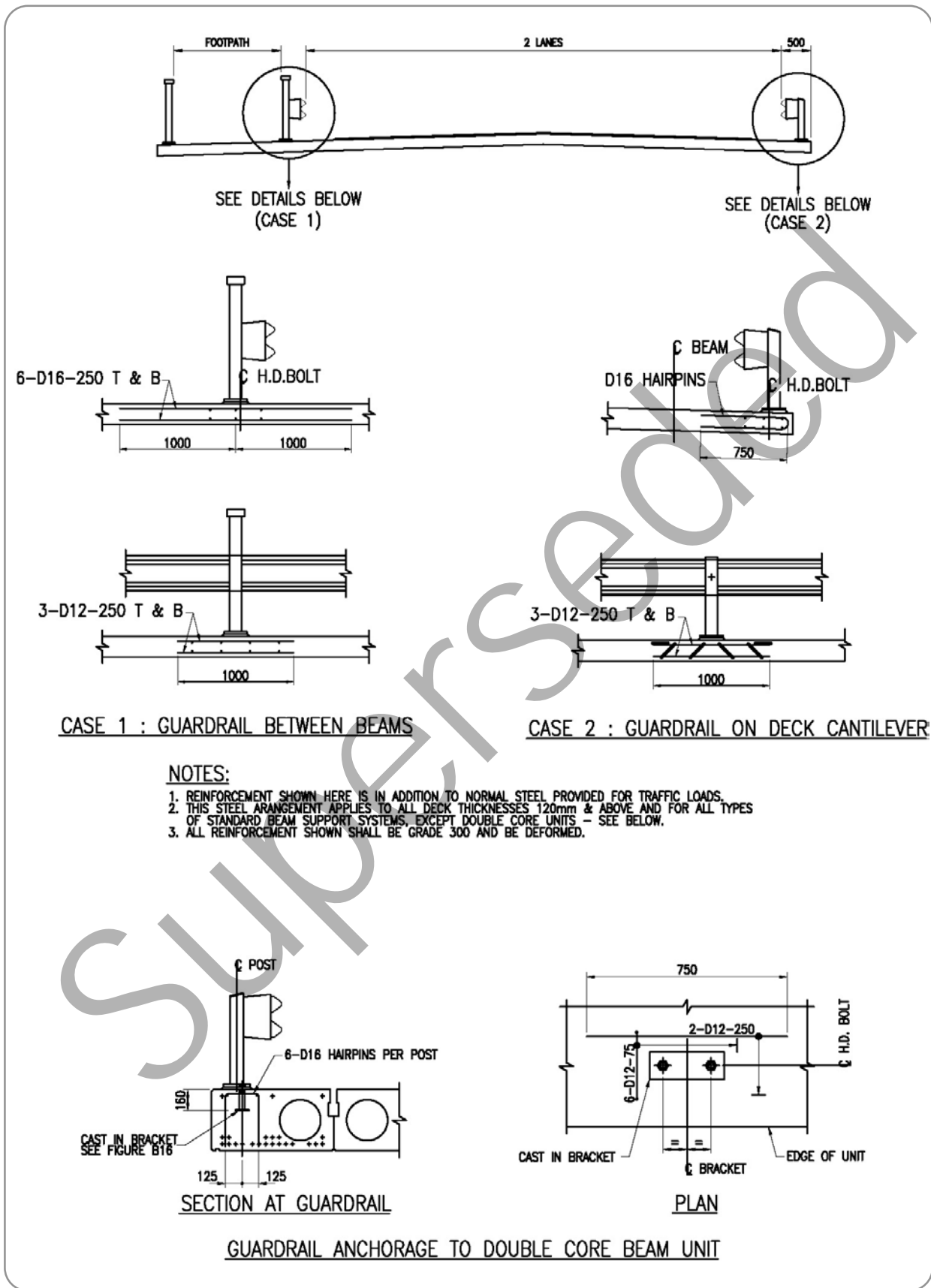
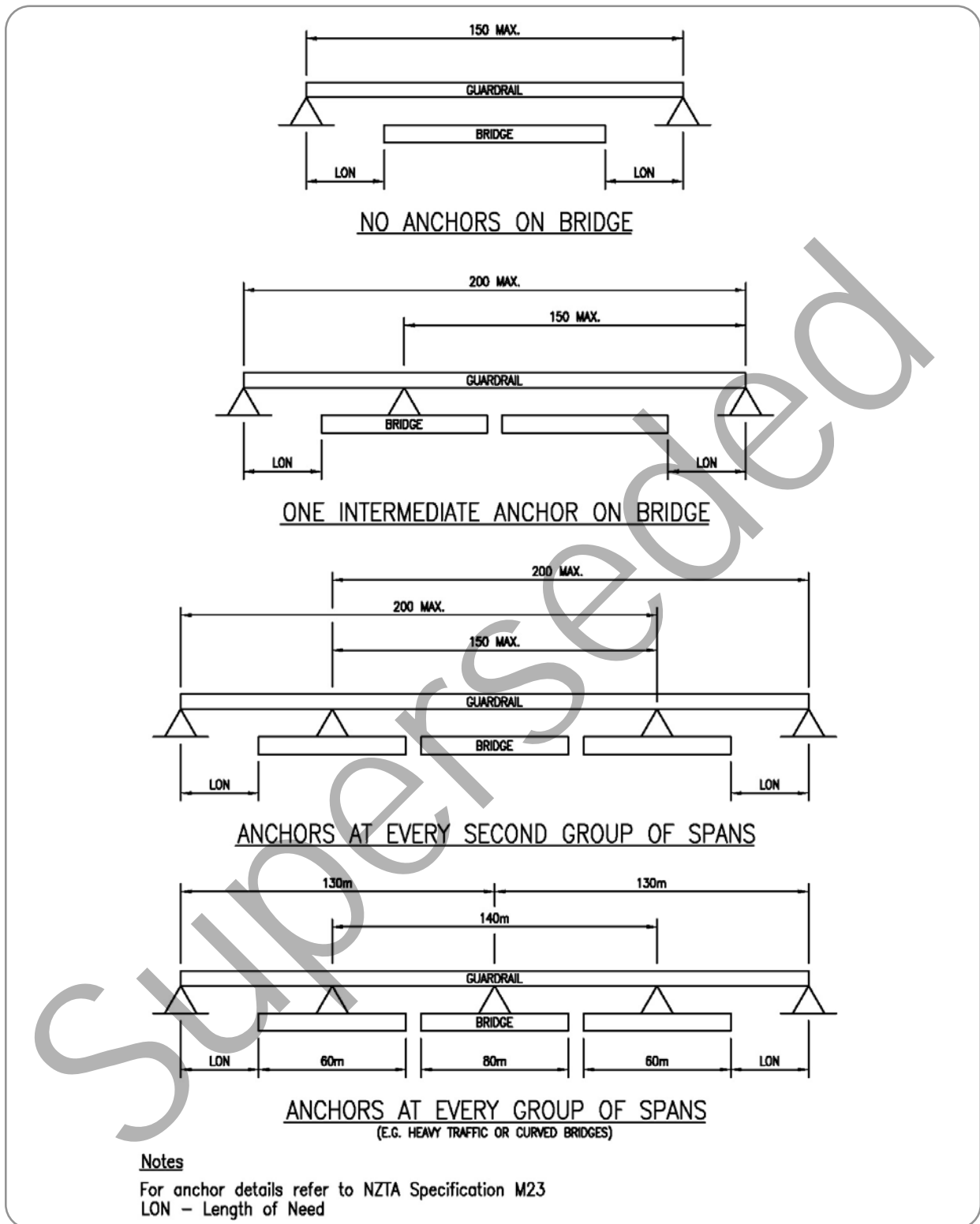

Figure B6: Non-proprietary bridge barrier system - anchor locations



B9 References

- (1) Austroads (2010) *Guide to road design*. Part 6 Roadside design, safety and barriers, AGRD06-10. Sydney, NSW, Australia.
 - (2) NZ Transport Agency (2009) *NZTA M23 Specification for road safety barrier systems*. Wellington.
 - (3) Parliamentary Counsel Office (1992) *Building Regulations 1992. Schedule 1 The building code*. Wellington.
 - (4) Ministry of Business, Innovation & Employment (2007) *Compliance document for New Zealand building code clause F4 Safety from falling*. Wellington.
 - (5) Ministry of Business, Innovation & Employment (2012) *Best practice guidelines for working at height in New Zealand*. Wellington.
 - (6) National Cooperative Highway Research Program (1993) *Recommended procedures for the safety performance evaluation of highway features*. Report 350, National Academy Press, Washington DC, USA.
 - (7) NZ Transport Agency (2013) *Economic evaluation manual*. Wellington.
 - (8) Standards Australia AS 5100.1-2004 *Bridge design*. Part 1 Scope and general principles.
 - (9) Standards Australia and Standards New Zealand jointly AS/NZS 3845:1999 *Road safety barrier systems*.
 - (10) Federal Highway Administration *Bridge railings*. Last accessed 6 May 2016 <www.safety.fhwa.dot.gov/roadway_dept/policy_guide/road_hardware/barriers/bridgerailings/index.cfm>.
 - (11) California Department of Transportation (2014) *Design criteria of standard earth retaining systems*. Memo to designers 5-5, Sacramento, CA, USA.
 - (12) Ministry of Business, Innovation & Employment (2014) *Acceptable solutions and verification methods for New Zealand building code clause B1 Structure*. Wellington.
 - (13) Austroads (2009) *Guide to road design*. Part 6A Pedestrian and cyclist paths, AGRD06A-09. Sydney, NSW, Australia.
-

Appendix C Seismic hardware

In this section

	Section	Page
C1	Linkage bars	C-2
C2	Toroidal rubber buffers	C-6
C3	References	C-7

Superseded

C1 Linkage bars

C1.1 Design standards

Linkage assembly design shall be designed and detailed based on these provisions and relevant clauses in AS/NZS 5100.6 *Bridge design* part 6 Steel and composite construction⁽¹⁾ and AS/NZS 5131 *Structural steelwork - Fabrication and erection*⁽²⁾; using the seismic design provisions given in NZS 3404:1997 *Steel structures standard*⁽³⁾, as well as clause 2.2.4 and table 3 of the withdrawn NZS 3404.1:2009 *Steel structures standard* part 1 Materials, fabrication, and construction⁽⁴⁾. (Member connection design is covered by AS/NZS 5100.6⁽¹⁾. However, for earthquake design AS/NZS 5100.6⁽¹⁾ clause 3.11 states that when the loadings given in this *Bridge manual* are applied, steel members and connections shall be designed and detailed in accordance with NZS 3404⁽³⁾.)

A capacity design approach should be used to ensure that any failure occurs in ductile linkage bars rather than in the anchoring brackets or in other members resisting the linkage forces.

Apart from AS/NZS 4671 *Steel reinforcing materials*⁽⁵⁾ for grade 300E and grade 500E bar, standard steel materials specifications generally do not specify the maximum UTS (ultimate tensile stress) for a grade of steel and within a steel grade a wide variation can be possible in the UTS of steel supplied, especially with stainless steels. Thus the designer will generally need to specify both the minimum yield strength and the maximum UTS of the linkage bars to be provided.

The capacity design force actions applied to the anchorages and resisting element of the linkage system should be based on the specified maximum UTS for the linkage bars. Experience has shown that the UTS given on material batch test certificates can differ by as much as 20% from the UTS of actual material supplied, when tested, and the possibility of this variation should be allowed for in the design by applying an overstrength factor of 1.2 to the specified UTS for the bars when estimating the force actions on the anchorages and resisting elements. Alternatively, tensile testing of the bar material actually supplied should be required to ensure that the specified maximum UTS of the linkage bars is not exceeded.

Strength reduction factors specified in the appropriate material codes should be used for the design of the anchoring brackets and members resisting the linkage forces.

In assessing the performance of the anchors and resisting members of existing linkage systems, an overstrength factor of 1.2 should be applied to the probable ultimate strength of the bar, where estimated based on literature reports of typical strengths or adopted from material batch test certificate records, and strength reduction factors should not be applied.

Guidance on the performance of linkage bars can be found in the report *Performance of linkage bolts for restraining bridge spans in earthquakes*⁽⁶⁾ or in the related summary paper⁽⁷⁾.

C1.2 Materials

C1.2.1 General

Linkage bars, other than cast-in bars protected by concrete in precast hollow core superstructures, should be formed from one of the following materials:

- grade 316 stainless steel, or a duplex grade or better, with equivalent corrosion resistance, having a specified minimum elongation of 25% and complying with BS EN 10088-3 *Stainless steels* part 3 Technical delivery conditions for semi-finished products, bars, rods, wire, sections and bright products of corrosion resisting steels for general purposes⁽⁸⁾ or an equivalent approved standard

C1.2 continued

- grade 300 L15 mild steel, hot dip galvanized and complying with AS/NZS 3679.1 *Structural steel part 1 Hot-rolled bars and sections*⁽⁹⁾
- Macalloy fully threaded S650 grade 316 stainless steel bar
- Reidbar grade 500E, hot dip galvanized.

Linkage bars protected by concrete in precast hollow core superstructures should be formed from grade 500E, micro-alloyed, hot dip galvanized reinforcing bar.

Linkage bars in new bridges, except for bridges with cast-in bars protected by concrete cover in hollow core unit superstructures, should be fabricated from grade 316 stainless steel (or an equivalent duplex grade or better) or Macalloy fully threaded S650 grade 316 stainless steel.

The preferred material is grade 316 stainless steel (or an equivalent duplex grade or better) because of its good elongation, corrosion resistance and good fracture toughness in cold temperatures.

Reidbar should not be used in areas where the AS/NZS 5100.6⁽¹⁾ lowest one-day mean ambient temperature (LODMAT) isotherm is less than 2.5°C.

C1.2.2 Ductility

Linkage bars should be designed to have a plastic elongation of at least 40mm. The test results in *Performance of linkage bolts for restraint of bridge spans in earthquakes*⁽⁶⁾ can be used to estimate the plastic elongations for the recommended linkage bar materials listed in C1.2.1.

When formed into bars of typical lengths used in bridge linkage systems, high strength steels generally do not have sufficient tensile ductility and should not be used unless results of full-scale bar testing demonstrates that the plastic elongations will exceed 40mm. (Certified material elongations do not give a reliable indication of the bar performance in a full-scale linkage system.)

C1.2.3 Fracture toughness

To allow for plastic strains under earthquake loads the steel used in linkage bars should have a minimum impact resistance of 27 joules at 10°C lower than the basic LODMAT isotherm for the site given in AS/NZS 5100.6⁽¹⁾.

It is not necessary to combine extreme low temperatures with design level earthquake loading and the provisions of AS/NZS 5100.6⁽¹⁾ can be interpreted as requiring linkages at sites on most of the coastal South Island regions to have an impact resistance of 27 joules at -10°C.

The steel used in anchoring brackets for linkage bars should have a minimum impact resistance of 27 joules at 5°C lower than the basic LODMAT isotherm for the site given in AS/NZS 5100.6⁽¹⁾. This allows for extreme cold conditions at the bridge site but does not include a plastic strain reduction since brackets should be designed so that they are not subjected to significant plastic strain.

Grade 316 and Macalloy S650 stainless steel have good fracture toughness and can be used for linkage bars at any location in New Zealand. The fracture toughness of mild steels should be assessed before they are used in the South Island and colder regions in the North Island. Grade 300 L15 should be satisfactory in all but the coldest regions of the South Island.

Reidbar assemblies should not be used in the South Island and if used elsewhere the site service temperature needs careful consideration.

C1.3 Bar geometric details

In bridges over 50m in length non-proprietary bars should have turned down shanks. The turned-down length should be a minimum of 10 times, and ideally 15 times, the turned-down diameter. The ratio of the turned-down diameter to nominal thread diameter should not be greater than 0.8.

It is not necessary to turn-down Reidbar or Macalloy bar. Turning down these bars is likely to reduce the total elongation.

If plain round linkage bars are used, they should have a shank diameter no greater than the nominal thread diameter and the loaded lengths of thread at both ends of the bar should be at least 3.5 times the nominal thread diameter. Their use should be restricted to bridges less than 50m in length or for retrofitting older bridges.

C1.4 Linkage bar nuts

It is essential that lock nuts be used on all linkage assemblies. On proprietary bars the proprietary lock-nuts can be used. Other bars should be lock-nutted using two standard nuts.

Nuts should have specified proof loads greater than the ultimate tensile strength (UTS) of the bar. The property class required for the nuts should be included in the bar specification.

C1.5 Rubber pads and washers

When rubber pads are used in the linkage system to accommodate the required temperature movements they should be specifically designed and should not be excessively flexible. The elastic stiffness of the linkage system should be as high as practicable to minimise damage to the span joints and holding down bolts under serviceability level earthquake loading.

Heavy steel washers should be used with rubber pads and should be of sufficient thickness to result in uniform pressures on the pads. Their side dimension, or diameter, should be at least as great as that of the rubber pad.

C1.6 Linkage system corrosion resistance

In new bridges and in bridges being seismically retrofitted, bar hardware and steel anchoring brackets shall be designed to have no significant loss of section in a 40-year service life. If the future life of a bridge being retrofitted is expected to be less than 25 years then the design service life of the linkage system may be reduced to 25 years.

In locations with a surface specific corrosion category of C4, and C5M as given in table 4.1 of *Protective coatings for steel bridges: a guide for bridge and maintenance engineers*⁽¹⁰⁾, grade 316 stainless steel (or an equivalent duplex grade or better) shall be used for new and retrofitted linkage bars. Stainless steel linkage bars shall also be used in specific corrosion category C3 (or above) locations if they are inaccessible for replacement or future maintenance. Linkage bars may yield under severe seismic response and in order to spread yielding along the length of the bar the uniformity of the bar cross-section shall be maintained throughout its design life. Allowing the corrosion of a sacrificial thickness of steel should not be adopted as a means of achieving the design life.

To achieve a 40-year service life it will be necessary to apply a paint coating to galvanized bars, bar hardware and anchoring brackets. Reference should be made to *Protective coatings for steel bridges: a guide for bridge and maintenance engineers*⁽¹⁰⁾ for bridge site atmospheric corrosivity categories and coating systems. In higher corrosivity areas (C3-C5) a high build paint system is required, and its integrity needs to be maintained throughout its service life.

C1.7 Linkage bar design details

C1.7.1 Serviceability limit state stresses

The stresses in the linkage bar system should be less than yield level under the load combinations specified for the serviceability limit state.

Where tight linkages are used they may be subjected to cyclic loading causing fatigue. The stress range in the linkage bar system induced by the combination of all load combination 2A serviceability limit state transient loads in accordance with table 3.1 (ie normal live load with dynamic load impact factor, horizontal and centrifugal effects of traffic loading, and overall and differential temperature effects) shall not exceed 150MPa.

C1.7.2 Bar anchoring at abutments and piers

Anchoring linkage bars and anchor brackets by drilling through the bridge main members and installing nuts is preferred to relying on anchoring bars and bolts with epoxy grout.

C1.7.3 Bar robustness

Thread damage, bending of bars during maintenance operations and corrosion of nuts due to galvanic action are considerations in detailing linkage bars. Diameters of less than 20mm should not be used for either galvanized mild steel or stainless steel linkage bars.

C1.7.4 Bar clearances

Adequate clearances and linkage bar hole sizes should be specified to reduce the risk of damage to linkage bars under combined longitudinal and transverse displacements of the superstructure.

C1.7.5 Linkage systems to be removable

With the exception of hollow core unit bridge superstructures that adopt the linkage detailing presented in NZTA research report 364 *Standard precast concrete bridge beams*⁽¹¹⁾, horizontal linkages and hold-down bolts/linkages, shall be designed to be removable and replaceable as they may yield or be damaged under severe seismic response.

C1.7.6 Protection of cast-in bars in hollow core unit bridge superstructures

For galvanized steel bars the debonding sleeve used across the joints between hollow core units at the piers and abutments shall be a viscoelastic wrapping such as the full Denso wrapping system. It shall consist of a paste, petrolatum tape and outer wrap tape. Rubber sleeving may be used to debond grade 316 stainless ribbed reinforcement bars.

C2 Toroidal rubber buffers

Figure C1: Toroidal rubber buffers

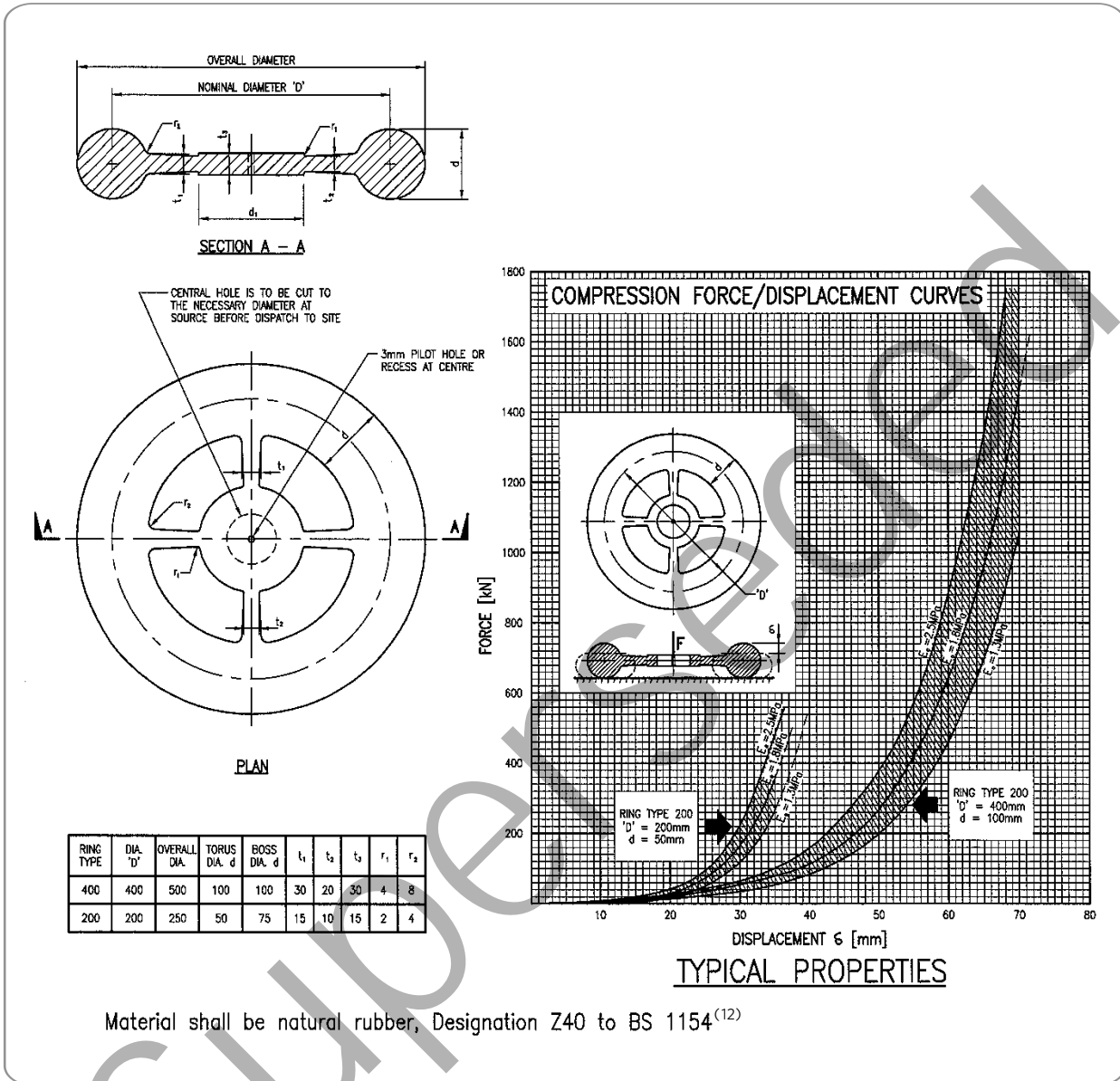

C3 References

- (1) Standards Australia and Standards New Zealand jointly AS/NZS 5100.6:2017 *Bridge design*. Part 6 Steel and composite construction.
 - (2) Standards Australia and Standards New Zealand jointly AS/NZS 5131:2016 *Structural steelwork - Fabrication and erection*.
 - (3) Standards New Zealand NZS 3404 Parts 1 and 2:1997 *Steel structures standard*.
 - (4) Standards New Zealand NZS 3404.1:2009 *Steel structures standard*. Part 1 Materials, fabrication, and construction. Withdrawn.
 - (5) Standards Australia and Standards New Zealand jointly AS/NZS 4671:2001 *Steel reinforcing materials*.
 - (6) Wood JH (2012) *Performance of linkage bolts for restraining bridge spans in earthquakes*. Report prepared for the NZ Transport Agency, Wellington.
 - (7) Wood JH and Chapman HE (2013) *Performance of linkage bars for restraint of bridge spans in earthquakes*. Bulletin of the New Zealand Society for Earthquake Engineering, vol. 46, no. 1.
 - (8) British Standards Institution BS EN 10088-3:2014 *Stainless steels*. Part 3 Technical delivery conditions for semi-finished products, bars, rods, wire, sections and bright products of corrosion resisting steels for general purposes.
 - (9) Standards Australia and Standards New Zealand jointly AS/NZS 3679.1:2016 *Structural steel*. Part 1 Hot-rolled bars and sections.
 - (10) NZ Transport Agency (2017) *Protective coatings for steel bridges: a guide for bridge and maintenance engineers*. Wellington.
 - (11) NZ Transport Agency (2008) *Standard precast concrete bridge beams*. Research report 364, Wellington.
 - (12) British Standards Institution BS 1154: 2003 *Natural rubber compounds*. Specification.
-

(This page is intentionally blank)

Superseded

Appendix D Lightly trafficked rural bridges and other structures

In this section	Section	Page
	D1 General	D-2
	D2 Specific requirements	D-2
	D3 References	D-6

D1 General

Use of the criteria in this appendix will be subject to approval of the road controlling authority.

- a. Note that this appendix provides minimum design standards.

These criteria apply to one-lane bridges and other structures (eg culverts, stock underpasses and subways) carrying a one lane carriageway on lightly trafficked roads. The criteria shall only be used where all the following criteria are met:

- i. the traffic count is less than 100 vehicles per day (vpd)
 - ii. the road cannot become a through route
 - iii. the alignment is such that speeds are generally below 70km/h
 - iv. use of the route by logging trucks is unlikely, and
 - v. no significant overloads are expected to occur or the structure can be bypassed.
- b. Following each clause title below, is the number of the clause in the main body of this document which is modified by this appendix. Where no modification is detailed below, the original clauses shall apply in full.

D2 Specific requirements

D2.1 Basis of design (2.1.3)

Not used.

D2.2 Geometric requirements (2.2)

The specific requirements of appendix A may be waived but the following width limits apply:

- a. Bridges and other applicable structures without handrails or traffic barriers: 3.0m minimum, 3.7m maximum between kerbs or wheel guards.
- b. Bridges and other applicable structures with pedestrian barriers: 3.0m minimum, 3.7m maximum between kerbs or wheel guards, 3.7m minimum between pedestrian barriers.
- c. Bridges and other applicable structures with traffic barriers: 3.7m minimum, 4.3m maximum between guardrails.

Traffic barriers may be omitted as detailed in B3.1.6 and pedestrian barriers may be omitted where pedestrians are not likely to frequent the structure, noting the requirements of B2.9 for the occasional presence of people.

Since agricultural vehicles up to 3.7m width may use a public road without permit, the choice of type and height of side protection should be made after consideration of the actual vehicles using the road, and the clearance to any overhanging portions of the vehicles.

D2.3 Traffic loads - gravity effects (3.2)

- a. For design of both main members and decks, the HN design load may be replaced by 0.85 HN. The dimensions of the loaded areas remain the same as for full HN load. HO load need not be considered.
- b. Areas of deck where wheels cannot normally travel, due to dimensional limitations or physical barriers need not be designed for the wheel loads of (a) above, but shall be designed for one 15kN wheel load, using the same contact area as an HN wheel, placed anywhere on the deck.

D2.3 continued

c. Note that the uniformly distributed part of the reduced HN load is expected to be adequate to cover the effect of all routine stock load.

D2.4 Combination of load effects (3.5)

Tables 3.1 and 3.2 shall be replaced by tables D1 and D2 respectively.

Table D1: Load combinations and load factors for the serviceability limit state

Load symbol	Combination																				
	DL	EL	SG	PS	EP	GW	ST	OW	CN	LLxI	HE	CF	CO	FW	PW	EQ	WD	TP			
Primary normal traffic cases	1A	1.00	1.00	1.00	1.00	1.00	1.00	1.00	1.00	1.00	1.00	1.00	1.00	1.00	1.00	1.00	1.00	1.00	1.00		
	1B	1.00	1.00	1.00	1.00	1.00	1.00	1.00	1.00	1.00	1.00	1.00	1.00	1.00	1.00	1.00	1.00	1.00	1.00		
	2A	1.00	1.00	1.00	1.00	1.00	1.00	1.00	1.00	1.00	1.00	1.00	1.00	1.00	1.00	1.00	1.00	1.00	1.00		
	2B	1.00	1.00	1.00	1.00	1.00	1.00	1.00	1.00	1.00	1.00	1.00	1.00	1.00	1.00	1.00	1.00	1.00	1.00	1.00	
	2C	1.00	1.00	1.00	1.00	1.00	1.00	1.00	1.00	1.00	1.00	1.00	1.00	1.00	1.00	1.00	1.00	1.00	1.00	1.00	
Primary lateral load cases	3A	Not applicable – see 3.5(d)										1.00	1.00	1.00	1.00	1.00	1.00	1.00	1.00	1.00	
	3B	1.00	1.00	1.00	1.00	1.00	1.00	1.00	1.00	1.00	1.00	1.00	1.00	1.00	1.00	1.00	1.00	1.00	1.00	1.00	
	3C	1.00	1.00	1.00	1.00	1.00	1.00	1.00	1.00	1.00	1.00	1.00	0.67	1.00	1.00	1.00	1.00	1.00	1.00	1.00	
Traffic overload case	4	Not applicable										1.00	1.00	1.00	1.00	1.00	1.00	1.00	1.00	1.00	1.00
Construction cases	5A	1.00	1.00	1.00	1.00	1.00	1.00	1.00	1.00	1.00	1.00	1.00	1.00	1.00	1.00	1.00	1.00	1.00	1.00	1.00	
	5B	1.00	1.00	1.00	1.00	1.00	1.00	1.00	1.00	1.00	1.00	1.00	1.00	1.00	1.00	1.00	1.00	1.00	1.00	1.00	

Notes: Where the effect of a possible reduction in permanent load is critical, replacement of the 'permanent load' by '0.9 x permanent load' shall be considered.

Table D2: Load combinations and load factors for the ultimate limit state

Load symbol	Combination		Permanent										Traffic			Environmental								
	DL	EL	SG	PS	EP	GW	ST	OW	CN	LLxI	HE	CF	CO	FW	PW	TS	EQ	WD	TP					
Primary normal traffic cases	1A	1.10 (1.00)	1.10 (1.00)	1.00 (1.00)	1.49 (1.35)	1.00 (1.00)	1.10 (1.00)	1.10 (1.00)	1.10 (1.00)	1.10 (1.00)	1.10 (1.00)	1.84	-	-	-	-	-	-	-	1.38				
	1B	1.10 (1.00)	1.10 (1.00)	1.00 (1.00)	1.49 (1.35)	1.00 (1.00)	1.10 (1.00)	1.10 (1.00)	1.10 (1.00)	1.10 (1.00)	1.10 (1.00)	-	-	-	-	-	-	-	-	-	-			
Secondary normal traffic cases	2A	1.20 (1.00)	1.20 (1.00)	1.00 (1.00)	1.20 (1.00)	1.00 (1.00)	1.20 (1.00)	1.20 (1.00)	1.20 (1.00)	1.20 (1.00)	1.20 (1.00)	1.20	-	-	-	-	-	-	-	1.20				
	2B	1.20 (1.00)	1.20 (1.00)	1.00 (1.00)	1.20 (1.00)	1.00 (1.00)	1.20 (1.00)	1.20 (1.00)	1.20 (1.00)	1.20 (1.00)	1.20 (1.00)	1.20	-	-	-	-	-	-	-	-	1.00			
	2C	1.20 (1.00)	1.20 (1.00)	1.00 (1.00)	1.20 (1.00)	1.00 (1.00)	1.20 (1.00)	1.20 (1.00)	1.20 (1.00)	1.20 (1.00)	1.20 (1.00)	1.20	-	-	-	1.00	-	-	-	-	-	-		
Primary lateral load cases	3A	1.00	1.00	1.00	1.25	1.00	1.00	1.25	1.00	1.00	1.00	-	-	-	-	-	-	-	-	0.33				
	3B	1.00	1.00	1.00	1.25	1.00	1.00	1.25	1.00	1.00	1.00	-	-	-	-	-	-	-	-	-	1.00			
	3C	1.00	1.00	1.00	1.25	1.00	1.00	1.25	1.00	1.00	1.00	-	-	-	-	-	-	-	-	-	-	0.33		
3D	Not applicable																							
3E	1.00	1.00	1.00	1.00	1.25	1.00	1.00	1.25	1.00	1.00	1.00	-	-	-	-	-	-	-	-	-	-	0.33		
4	Not applicable																							
Construction cases	5A	1.20 (1.00)	1.20 (1.00)	1.20 (1.00)	1.00 (1.00)	1.00 (1.00)	1.00	-	1.20 (1.00)	1.32	-	-	-	-	-	-	-	-	-	-	-	-	0.33	
	5B	1.20 (1.00)	1.20 (1.00)	1.20 (1.00)	1.00 (1.00)	1.00 (1.00)	1.00	-	1.20 (1.00)	1.32	-	-	-	-	-	-	-	-	-	-	-	-	-	1.00
	5C	1.20 (1.00)	1.20 (1.00)	1.20 (1.00)	1.00 (1.00)	1.00 (1.00)	1.00	-	1.20 (1.00)	1.32	-	-	-	-	-	-	-	-	-	-	-	-	-	-

Notes: Where the effect of a possible reduction in a permanent load is critical, use of the lower bracketed load factors shall be considered.

Combination 3D applies only to the design of footbridges.

† γ_{FL} shall be as defined in 3.4.8(a)

D2.5 Reinforced concrete and prestressed concrete - General (4.2.1)

Design shall be in accordance with NZS 3101.1&2 Concrete structures standard⁽¹⁾, as amended by 4.2.1, with the following further provisos:

a. Crack widths (clause 2.4.4.2)

Crack widths under the application of load combination 1B as defined in table D1 shall not exceed the limits specified in table D3 unless alternatively the requirements of NZS 3101⁽¹⁾ clause 2.4.4.1(a) are satisfied.

Table D3: Crack width limits

	Exposure classification	Crack width limit
Reinforced concrete	A2, B1, B2	0.40mm
Prestressed concrete		0.30mm
Reinforced concrete	C	0.30mm
Prestressed concrete		0.20mm

b. Permissible service load stress ranges in prestressed reinforcement (clause 19.3.3.6.2(a) and (b))

The stress range due to infrequent live loading by clause 19.3.3.6.2(b) shall be taken as that applicable to live loading acting on lightly trafficked rural bridges and other structures to which this appendix applies.

D3 References

- (1) Standards New Zealand NZS 3101.1&2:2006 *Concrete structures standard*.
(Incorporating Amendment No. 3: 2017)
-

Superseded

Appendix E Structure site information summary

Notes

1. This summary, together with accompanying drawings and documents, contains the basic data needed for the start of detailed design action for the proposed structure.
2. Both the scheme plan and the site plan shall accompany the structure site information summary.
3. Section 2 can be omitted in its entirety for road and railway overbridges and underpasses.
4. The 'designated person' referred to at the start of sections 1 to 5 below would typically be:

Section 1	Basic Information:	An engineering consultant familiar with the site.
Section 2	River data: 2.1 to 2.4:	An engineering consultant familiar with the site.
	2.5 to 2.8:	Regional council or territorial authority.
Section 3	Site investigations:	A site investigator.
Section 4	Recommendations:	A senior professional engineer.
Section 5	Approvals:	A senior professional engineer.

Section 1: Basic information

To be completed by the designated person

1.1	General	
.01	Name of bridge, culvert or other structure	
.02	State highway number and section, or other route definition	
.03	Route position, ie reference station plus displacement	
.04	Name of river to be bridged or name and position of road or railway to be crossed	
.05	Roads district	
.06	Local authorities Regional council and/or territorial authority	
.07	Scheme plan: a. Number b. Date of submission to the NZ Transport Agency (NZTA) c. NZTA approval date	
.08	Site plan number	
.09	Level datum used for: a. Scheme plan b. Site Plan	
.10	Map reference (LINZ Topo50 series) Map number Date Coordinates of the site of the structure	East North
.11	Photographic references a. NZTA state highway aerial strip: <ul style="list-style-type: none"> • photographs • survey number • run number • photograph number b. Supply site photographs with date(s) taken	

1.2	Existing structure	
.01	Details <ul style="list-style-type: none"> a. Plan number b. Where held c. When built d. Bridge deck level or reference level on deck using site plan datum / culvert or subway diameter or height e. Bridge soffit level / culvert or subway invert level 	
.02	Where drawings are not available, provide brief description of existing structure	
.03	Overload rating <ul style="list-style-type: none"> a. Bridge classification b. Deck grading 	
.04	Bridge posting limits <ul style="list-style-type: none"> a. Wheel base load b. Axle load c. Speed restriction 	
.05	Foundations <ul style="list-style-type: none"> a. Type b. Has performance been adequate? c. Any known problems during construction? d. Append detailed information if available, eg pile size, length, penetration, driving records, borelogs, design bearing values or other, as appropriate. e. Do existing foundations restrict the location of new piers and abutments? f. Should they be removed? g. To what level? h. Why? 	
.06	Are there special problems at the site of the existing structure, eg: <ul style="list-style-type: none"> a. Scour b. Settlement c. Fill stability d. Floating debris e. Corrosion f. Other - specify (provide report as appropriate) 	

1.3 Factors to be considered during design						
.01	Nature and volume of present traffic					
.02	Vehicle route importance category Level of serviceability to traffic Is this different from the recommended value If yes, specify	YES/NO				
.03	Nature and extent of stock traffic					
.04	Is stock or other access required under the bridge or through the structure?					
.05	Services to be carried on the structure	Side of bridge	Number	Nominal Diameter	Diameter Over Joints	Fixing Methods
	a. Sewer mains					
	b. Telecom cables					
	c. Water mains					
	d. Gas mains, state high or low pressure					
	e. Power cables					
	f. Other services					
.06	Has each authority been informed of the NZTA's policy for cost sharing?					
.07	Lighting requirements					
.08	Extreme shade temperatures °C					
.09	Has an environmental impact assessment been prepared? If so, attach copy					
.10	Does the appearance of the structure in elevation warrant special consideration?					
.11	Preferred construction materials					
.12	Preferred deck surface material and finish					
.13	Restrictions on transport and access to site					
.14	Construction restraints at the site, eg flash floods, dewatering					
.15	Other factors to be considered					
.16	Waterway recommendation. Suggested length of bridge for consistency with:					
	a. The existing channel, or					
	b. Any existing or planned river training works					
.17	Flood clearance recommendation from natural flood stage to underside of superstructure, and any requirement for minimum waterway area.					

.18	<p>Clearances for tidal and navigable waterways</p> <ol style="list-style-type: none"> Type of craft, eg yachts, jet boats, barges Recommend the highest water level at the site above which navigational clearance should be provided. Use site plan datum. Give reasons for choice What is the minimum clearance and width restriction imposed by: <ol style="list-style-type: none"> Existing bridge Other nearby structures From the local knowledge, what is the recommendation for the navigational channel(s): <ol style="list-style-type: none"> Vertical clearance Centreline location and width of navigation channel 	
-----	---	--

Certification	
Section 1	
Prepared by:	Designation:
Certified by:	Designation:
Date	

Section 2: River data

To be completed by the designated person and the regional council or territorial authority as appropriate

2.1		Catchment topography
.01	a. Area of catchment above site b. How was area obtained?	
.02	General slope (eg flat, gently rolling, rolling, hilly, mountainous)	
.03	Range of heights above sea level	
.04	Shape of catchment (eg long, circular, pear, fan)	
.05	Surface soil and subsoil (eg pumice, clay, loam, sand, rock). Give approximate percentage of catchment area for each type	
.06	Percentage cover: a. In bush, scrub or forest b. In pasture c. In cultivation d. Cleared but reverting e. In urban development	
.07	Are these percentages likely to vary in the life of the structure?	
.08	Any general comments on catchment characteristics?	
2.2		Water levels
.01	a. Normal water level, ie water level exceeded for 30% of the time, using site plan datum b. Mean velocity and orientation of this flow (show on diagram) c. How was this assessed?	
.02	a. Lowest known water level using site plan datum b. Date c. How was value obtained?	
.03	a. List highest known flood levels using site plan datum b. Orientation of flow (show on diagram) c. Date(s) d. How were values obtained?	
.04	Tidal sites: Levels at the site in terms of site plan datum. Give as many of the following levels as possible and state how data were obtained, including tide gauge reference: a. Highest known tide and data b. Lowest known tide and data c. Mean high water spring tide d. Mean high water neap tide e. Mean low water neap tide f. Mean low water spring tide	
.05	What is the approximate maximum wave height at the site?	
.06	Is water level affected by wind? Give details	

.07	Maximum size of driftwood carried at high flood flow	
.08	Bed gradient/Length over which measurements were taken	
.09	Gradient of water surface at proposed site for: <ul style="list-style-type: none"> a. Low to medium flow, specify water level at site when gradient obtained b. High flow, specify water levels at site when gradient obtained c. Gradients measured over what length of channel? d. Is length of floodway straight? If not, provide details 	
.10	<ul style="list-style-type: none"> a. Are there differences between low and high water surface slopes? b. If so, what are they and what are the reasons? 	
2.3	Waterway	
.01	<ul style="list-style-type: none"> a. Waterway area to highest known flood level at existing or nearby structure on same stream, normal to flow b. Has this proved adequate? Give wetted perimeter c. Is flood gradient at this site similar to that in 2.2.09(b)? If not, specify 	
.02	<ul style="list-style-type: none"> a. Cross-section area of channel to highest known flood level at site of new structure b. Is cross-section at proposed site typical of channel and floodway over a length up and downstream of at least five times width of flood waterway in each direction? c. If not, comment on variation and supply typical sections with the site drawings 	
.03	Bed material at structure site (eg silt, sand, fine or coarse gravel), provide typical grading of bed materials	
.04	Preliminary estimate of Mannings n for <ul style="list-style-type: none"> a. Channel b. Berm c. How were values obtained? 	
.05	<ul style="list-style-type: none"> a. Summarise measurements or records of local scour measured from general bed level with corresponding location, water levels and general bed level in terms of site plan datum b. How were values obtained? 	
.06	Is the depth of scour affected by: <ul style="list-style-type: none"> a. Direction of flow? b. Local riverbed shape? c. Other local effects (specify)? 	
.07	Are moderate flood conditions critical for scour? For example, with the main channel at bank full flow	

2.4 Channel stability and river works	
.01	Is the river channel braided, meandering, incised?
.02	<ul style="list-style-type: none"> a. Are the banks stable over a length of 1km upstream and downstream of structure site (erosion, slumping, slips, etc)? b. Are the banks stable at the existing structure site (erosion, slumping, slips etc)? c. Is there any existing protection or riverbed control work affecting conditions at the proposed site? d. Is bank/abutment protection suggested? If so, indicate type of protection
.03	Is there any possibility of river tending to cut off approaches?
.04	Is there any escape of floodwaters upstream and is there any possibility of this being reduced or prevented in future by a river control scheme? Give appropriate details
.05	Give details of current and/or projected extraction of riverbed material
.06	Is the riverbed aggrading, degrading or stable? Give results of measurements or estimates, the period involved and indicate how results were obtained
.07	Describe the influence of any future river improvement or catchment control or development works or other activities likely to affect structure location, area of waterway, flood stages, scour depths, layout etc.
2.5 Rainfall and water level records	
.01	Indicate variability of rainfall distribution expressed as a percentage of the average over the entire catchment.
.02	<ul style="list-style-type: none"> a. Location and map reference for the nearest rain gauge b. Length of time that records have been taken c. Type of gauge d. Relationship of records to catchment average intensity
.03	<p>Maximum recorded or known rainfall in mm</p> <ul style="list-style-type: none"> a. In 1 hour b. In 2 hours c. In 12 hours d. In 24 hours e. Above to catchment average intensity. How were records obtained? f. Corresponding return period
.04	<ul style="list-style-type: none"> a. Where is the nearest staff gauge or recorder station on this river? b. What is its number? c. Period over which water level records have been kept d. Supply stage/discharge stage/velocity and stage/area curves if available

2.6		Flood discharge	
.01	Is discharge affected by: a. Snow on catchment? b. Ponding upstream? c. Overflow from other catchments? d. Backwater from major river downstream or from lake, sea or beach barrier?		
.02	Estimated time of concentration at the site (for rational method)		
.03	For flood levels given in 2.2.03: a. Flood discharge b. Flood velocity c. Orientation of flow (show on diagram) d. Method used, ie estimate, timing debris, special measurements, rating curve, calculation e. Give estimate of reliability of results f. Average recurrence interval (ARI) of flood		
2.7		Design floods	
.01	Design rainfall in mm per hour for the time of concentration (2.6.02) on the basis of catchment average intensity. Specify standard deviation if possible		
.02	<u>Total waterway design flood</u> Design flood at the site with the recommended structure in place: a. Discharge b. Average recurrence interval (ARI) c. Mean velocity d. Water level in terms of site plan datum e. Orientation of flow (show on diagram)	Non tidal sites	Tidal sites
			MHWST
.03	<u>Level of serviceability to traffic design flood</u> Design flood to be passed without interruption to traffic: a. Discharge b. Average recurrence interval (ARI) c. Mean velocity d. Water level in terms of site plan datum e. Orientation of flow (show on diagram)	Non tidal sites	Tidal sites
			MHWST

.04	<p><u>Serviceability limit state design flood</u></p> <p>Design flood to be used for the serviceability limit state of the structure:</p> <ol style="list-style-type: none"> Discharge Average recurrence interval (ARI) Mean velocity Water level in terms of site plan datum Orientation of flow (show on diagram) 	Non tidal sites	Tidal sites	
			MHWST	MLWST
.05	<p><u>Ultimate limit state design flood</u></p> <p>Design flood to be used for the ultimate limit state of the structure:</p> <ol style="list-style-type: none"> Discharge Average recurrence interval (ARI) Mean velocity Water level in terms of site plan datum Orientation of flow (show on diagram) How was the estimate of the ultimate limit state design flood obtained? Attach calculations 	Non tidal sites	Tidal sites	
			MHWST	MLWST
	<p>Design flood to be used for the ultimate limit state of the bridge when the bridge deck level is overtopped by 200mm</p> <ol style="list-style-type: none"> Discharge Average recurrence interval (ARI) Mean velocity Water level in terms of site plan datum Orientation of flow (show on diagram) Detail the nature of any elements of the bridge likely to cause retention of debris at overtopping of the deck Attach calculations 			
.06	<p>State the calculated level of general scour at the proposed site (in terms of the site plan datum) under the design flood conditions assuming that the proposed structural elements constrict flow less than 10%. In addition, for cases where proposed approaches and fills are likely to constrict flow, the effects of these constrictions are to be calculated. Attach calculations and sketches</p>			
.07	<p>State the calculated levels of local and abutment scour at the proposed site (in terms of the site plan datum) under the design flood conditions. Calculations are to take into account the effect at constrictions. Attach calculations and sketches</p>			
.08	<p>Are the estimates of scour for the design floods appropriate for the site and the nature of the recommended structure? Should a more conservative level of scour be considered? Specify</p>			

.09	General comments on the determination of scour and bank stability	
.10	Describe the anticipated levels of scour under Ultimate Limit State design floods Is the structure overtopped at a lower ARI flood than the Ultimate Limit State design flood? Describe the anticipated levels of scour under the overtopping design flood	
2.8	General	
.01	a. Are resource consents required? b. If so, what is the status of the application?	
.02	Any general comments on river characteristics or problems?	

Certification	
Section 2	
Prepared by:	Designation:
Certified by:	Designation:
Date	

Section 3: Site investigations

To be completed by the designated person

3.0	Site investigations	
.01	Where some investigations have been carried out on the site <ol style="list-style-type: none"> a. Type of investigations: <ol style="list-style-type: none"> i. Walkover survey ii. Test pits iii. Penetrometer tests iv. Bores v. Test piles vi. Other, specify b. Show locations on site plan and provide a record of number, locations, depths, results, interpretation and conclusions c. Outline further investigations proposed 	
.02	Where no investigations have been carried out at the site: <ol style="list-style-type: none"> a. Describe the surface and anticipated subsurface conditions at the site for design report purposes b. What investigations are proposed? 	
.03	What is the depth of scourable material in the riverbed?	
.04	<ol style="list-style-type: none"> a. Are atmospheric, water and soil conditions likely to be aggressive to construction materials? b. If so, state details 	
.05	Position of abutments to provide safety against failure of banks caused by superimposed loading	
.06	Recommended safe batter slopes for approach earthworks (with allowance for seismic conditions)	
.07	Is consolidation or differential settlement likely at the bridge or approaches? If so, give details	
.08	Density of concrete made from local materials	
.09	Probable abrasive effect of material transported by the river on concrete and steel	
.10	Comment on presence of active geological faults	

Certification**Section 3**

Prepared by:

Designation:

Certified by:

Designation:

Date

Section 4: Recommendations

To be completed by the designated person

4.0	Recommendations	
.01	State any specific environmental (including aesthetic) considerations which should be allowed for in the design	
.02	Is a landscape design required? If so, who will be responsible?	
.03	Length of bridge or size of culvert	
.04	Clearance from natural flood stage to soffit of superstructure	
.05	State the preferred construction material and structural form	
.06	Do site conditions indicate specific pier or abutment locations? If so, show on site plan and state reasons	
.07	Suggested structure foundations: <ol style="list-style-type: none"> Type Depth Capacity General comments 	
.08	<ol style="list-style-type: none"> Preferred type of surface drainage layout for bridge and approaches Type, size, location of channels Preferred type and size of kerb Preferred type and size of side protection. Provide sketches as appropriate 	
.09	General comment	

Section 5: Approvals obtained

To be completed by the designated person

5.0	Approvals	
.01	Have proposals been discussed in detail with: <ol style="list-style-type: none"> Regional council Territorial authority. Specify Other interested parties. Specify 	
.02	Give file reference and date of the agreement or approval: <ol style="list-style-type: none"> Regional council Territorial authority. Specify. Other interested parties. Specify. 	
.03	<ol style="list-style-type: none"> Where over tidal or navigable waters have details been submitted to the Maritime Safety Authority for marine approval? Has marine approval in fact been granted? 	
.04	General comments and factors arising from 5.01 and 5.02 which should be considered in the design	

Certification			
Sections 4 and 5			
Prepared by:	<input type="text"/>	Designation:	<input type="text"/>
Certified by:	<input type="text"/>	Designation:	<input type="text"/>
Date	<input type="text"/>		

Superseded

Appendix F Technical approval, review and certification procedures

Not used. See *Highway structures design guide*⁽¹⁾ appendix A.

Superseded

F1 References

- (1) NZ Transport Agency (2016) *Highway structures design guide*. Wellington.
-

Superseded